

## TABLE OF CONTENTS, - Continued

<u>ITEM #</u>	<u>DETAIL</u>	<u>PAGE</u>
Standard Vertical Curb & Gutter	P-5	55
Mountable Curb	P-6	56
P. C. C. Cross Gutter	P-7	57
Standard Asphalt Dike	P-8	58
Typical Dike Installation	P-9	59
Trench Backfill Typical Section	P-10	60
Drainage Outlet	P-11	61
Storm Drain Inlet Type "A"	D-1	62
Storm Drain Inlet Type "B"	D-2	63
Storm Drain Inlet Type "C"	D-3	64
Standard Barricade	D-4	65
Driveway Setback	D-5	66
Standard Street Sign	D-6 & 6A	67
Subdivision Street Monuments & Accuracy		69
Survey Monument	D-7	70
Off Street Parking	D-8	71
Handicap Symbol	D-9	72
Wheel Chair Ramp	D-10	73
Gated Entrance	D-11	74
Standard Gate	D-12	75

Additional pedestrian and/or bicycle facilities may be required if there is a potential for concentrated pedestrian and/or bicycle traffic in the opinion of the County Engineer.

#### 10. CURB, GUTTER AND SIDEWALK

Vertical curb and gutter with monolithic sidewalk may be used if all driveway locations are predetermined and constructed at the time of the subdivision development.

If driveway locations are not provided with the road construction, mountable curb will be used and any required sidewalks will be located with one side contiguous with the right of way line. Refer to the typical sections and standard details. Mountable curb will not be used on steep grades where it would be a hazard to the public, as determined by the County Engineer.

#### 11. RESIDENTIAL DRIVEWAYS

As part of the construction of a new dwelling unit(s) or substantial improvements to an existing dwelling unit(s) requiring a building permit, property owner shall provide a minimum 10 foot wide driveway with an earth shoulder of 4 feet in total and proper turnouts, from the publicly maintained road to the new or improved structure. See detail C-10 for rural driveways, and detail D-5 and P-3 for urban driveways.

#### 12. COMMERCIAL, INDUSTRIAL AND NON-RESIDENTIAL DRIVEWAYS

As part of a new commercial, industrial, and non-residential (excluding Group U as defined by the California Building Code) use or improvements to an existing commercial, industrial or non-residential building requiring a building permit, property owner shall provide a min. 18' wide driveway from the publicly maintained road to the improved structure. See detail C-7, Common Drive, for cross-section information. See detail D-5 and P-4 for urban driveways and detail P-2 for rural driveways.

#### 13. STREET AND ROAD CLASSIFICATIONS

The following list of street and road types is intended to be representative of typical subdivision development and does not include all roads and streets that will be encountered. Geometric requirements relative to highways, expressways, major roads, access included in these Standards may be applied to a specific case and required or allowed. Regarding the requirements

relative to roads serving commercial and industrial areas see the appropriate subsequent sections. All roads are required to be paved with the exception of agricultural special purpose roads and rural driveways. Pavement section shall be determined by the designed Traffic Index. Minimum structural section shall be 2 inches of asphalt concrete over 5 inches of aggregate base.

### MAJOR ROADS

<u>Street or Road</u>	<u>Definition</u>
a) Arterial	Connects collectors to highways, and other major arterials; functions primarily to carry traffic, estimated volume 5000 vehicles per day or more. May be two or more lanes with or without median strips and controlled access.
b) Collector	Generally collects traffic from lesser roads and also serves as access to adjacent land. Traffic volume to 1000 to 5000 vehicles per day.

### MINOR ROADS

c) General Minor	Serves primarily as access to adjacent land, carries up to 1000 vehicles per day.
d) Loop Road and Non Continuing Minor*	Serves abutting property; carries up to 250 vehicles per day.
e) Cul-de-Sac *	Serves as an access road to abutting property; traffic volume up to 250 vehicles per day.
f) One Way Loop Roads	Special purpose roads depending on site circumstances; maximum length ¼ mile in flatland areas and ½ mile in hill areas; traffic volume up to 150 vehicles per day.
g) Common Drive	Serves as access to two, three, four, five or six parcels based on ultimate development. Developments that have a legal and practical potential for redivision into more than 6 parcels will not qualify for use of common drives.
h) Rural Driveway	Serves as the minimum access to a maximum of two buildings, with no more than three dwelling units on a single parcel, and any number of accessory buildings.

Roadway Surface: The surface shall provide unobstructed access to conventional drive vehicles. Road surfaces and structures shall be capable of supporting loads equivalent to the HS20-44 criterion (40,000 pound vehicle).

Road Radius: (a) No roadway shall have a horizontal inside radius of curvature of less than 50 feet and additional surface width of 4 feet shall be added to curves of 50-100 feet radius; 2 feet to those from 100-200 feet. (b) The length of vertical curves in roadways, exclusive of gutters, ditches, and drainage structures designed to hold or divert water, shall not be less than 100 feet.

Roadway Turnarounds: Turnarounds are required on driveways and dead-end roads. The minimum turning radius for a turnaround shall be 40 feet from the center line of the road. If a hammerhead/T is used, the top of the "T" shall be a minimum of 60 feet in length. See detail C-10.

Roadway Turnouts: Turnouts shall be a minimum of 10 feet wide and 30 feet long with a minimum 25 foot taper on each end. See detail C-10.

Roadway Structures: (a) All driveway, road, and private lane roadway structures shall be constructed to carry at least the maximum load and provide the minimum vertical clearance of 15 feet, (b) Appropriate signing, including but not limited to weight or vertical clearance limitations, one-way road or single lane conditions, shall reflect the capability of each bridge. (c) A bridge with only one traffic lane shall provide for unobstructed visibility from one end to the other and turnouts at both ends. Either railing or a minimum 6" high curb of suitable material shall be provided along the lengths of both sides of bridges.

One-Way Roads: All one-way roads shall be constructed to provide a minimum of one 10-foot traffic lane. All one-way roads shall connect to a two-lane roadway at both ends, and shall provide access to an area currently zoned for no more than 10 dwelling units. In no case shall it exceed 2640 feet in length. A turnout shall be placed and constructed at approximately the midpoint of each one-way road.

Left-Turn Lane Warrants: Use Permits or modifications thereof shall trigger the application of the following warrants to determine the necessity for a left-turn lane for entering the proposed use.

1. Application of the following Left-Turn Lane Warrant chart, based on Road ADT and projected ADT of use. The chart is a representation of probable conflict between turning traffic and advancing traffic. Private Road or Driveway ADT is the total average daily traffic utilizing the facility. A left-turn lane will not be considered for uses generating an ADT of 10 or less.
2. If sight distance in advancing direction, measured from the driveway, is less than required per Caltrans design standards (usually the posted speed limit multiplied by eleven, read in feet) a left-turn lane shall be installed.
3. If traffic conditions or turning movements pose a considerable threat to public life and safety, as recognized by the Director of Public Works, a left-turn lane shall be installed.

Design: Design of the Left-turn lane shall be prepared by a Licensed Civil Engineer and be based on the County Standard Detail LTL-1, available at the Public Works Department.

## 17. TYPICAL CROSS SECTIONS

The cross sections which follow are intended to represent typical applications in subdivision development and do not include all possibilities or elements of design that may be required or permitted. The minimum right of way for any street or road will not be less than forty feet. In addition, slope easements extending ten feet beyond the top of cut or toe of fill will be required whenever the vertical height of the cut or fill exceeds five feet. Easements are not required when cut or fill slopes are flatter than 3:1.

Please note that for simplification, mountable curb is not shown on the typical sections. When it is used, the sidewalks must be located as shown on the Standard Details.

Fill slopes higher than 10 feet will be protected with asphalt concrete dikes or other acceptable means. Super elevations and continuous cross slope streets without a crown may be permitted and encouraged in specific cases upon the approval of the County Engineer.

Left-Turn Lane Warrant

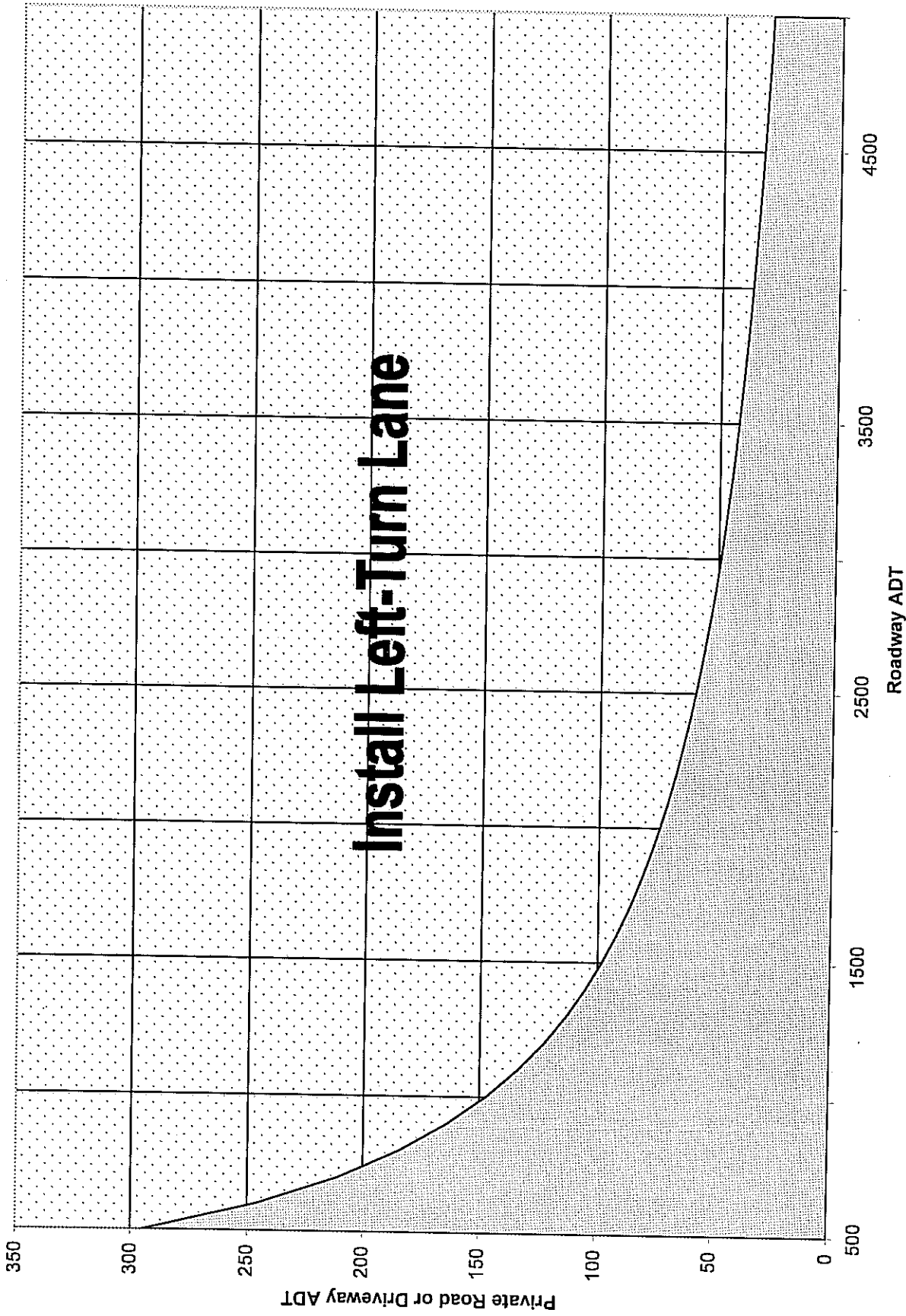

Install Left-Turn Lane

No Left-Turn Lane Necessary

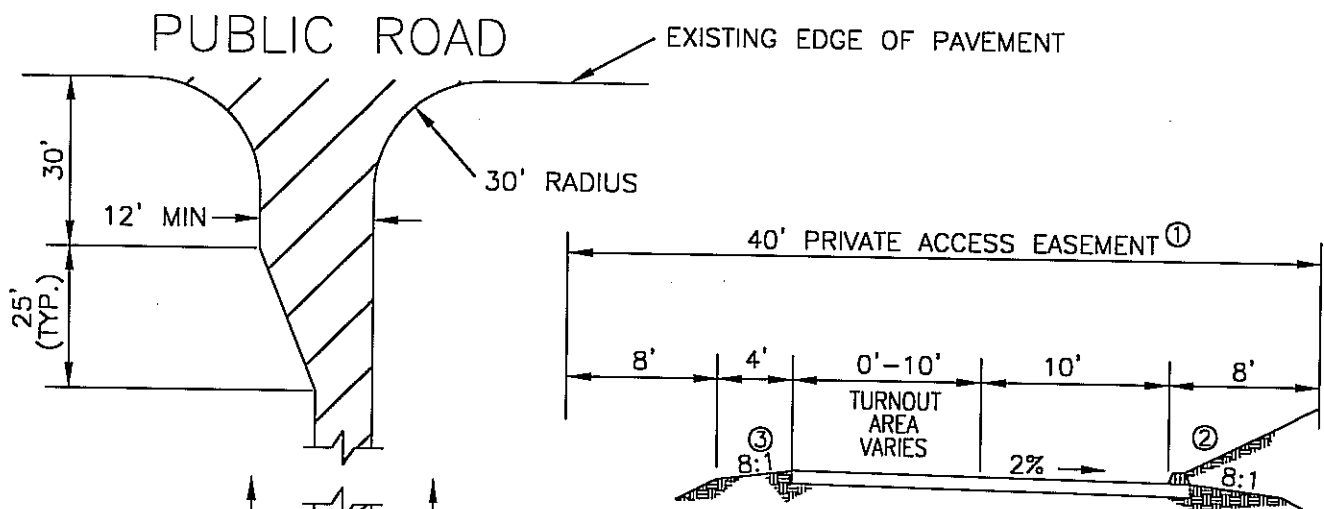

**SECTION A-A**

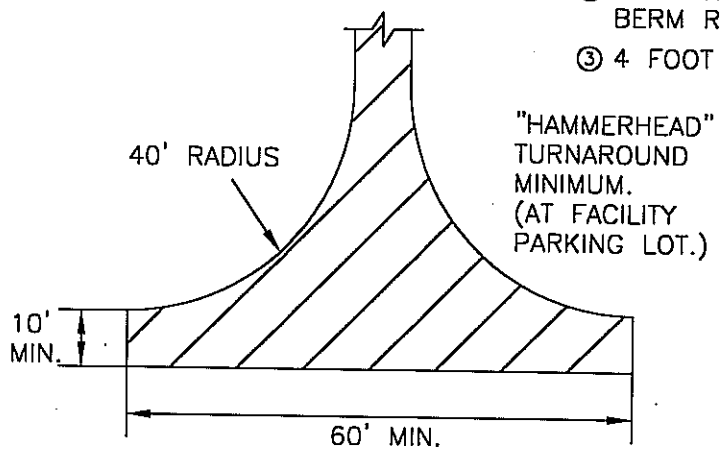
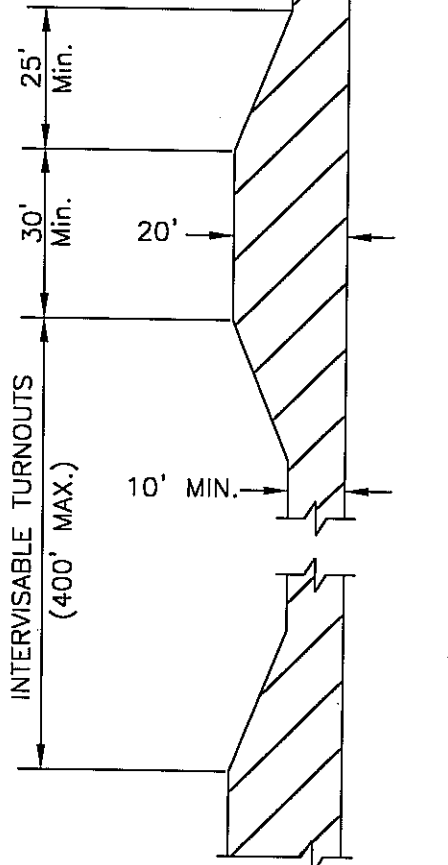

- 1A. RURAL DRIVEWAY TO BE SURFACED WITH AN ALL-WEATHER BASE MATERIAL SUITABLE FOR CONVENTIONAL DRIVE VEHICLES AND 4' GRADED SHOULDER
  - 1B. RESIDENTIAL DRIVEWAY AND AGRICULTURAL SPECIAL PURPOSE ROADWAY (MAXIMUM GRADE 16%) TO BE EQUIVALENT TO 5" CLASS II AB PLUS A DOUBLE SEALCOAT. MAXIMUM ADT: 100.
  2. TURNAROUND FACILITIES AT THE BUILDING SITE TO BE CONSTRUCTED SO AS TO ALLOW LARGE FIRE ENGINES TO TURN AROUND WITH A MINIMUM OF MANEUVERING. TURNAROUND SHALL BE WITHIN 50 FT OF BUILDING.
  3. MAXIMUM GRADE, NON-PAVED IS 16%  
MAXIMUM GRADE, PAVED (AC OR CONCRETE), IS 20%  
MINIMUM CENTERLINE CURVE RADIUS OF 50'
  4. ANY REQUIRED CULVERTS SHALL HAVE A MINIMUM LENGTH OF 14 FEET.
  5. OVERHEAD CLEARANCE OF LIMBS, TREES, ETC., SHALL BE A MINIMUM OF 15 FEET.
  6. CLEARLY DEFINED ADDRESS NUMBER PLACARD, 3" MIN. REFLECTORIZED LETTERING, TO BE PLACED AT THE PUBLIC ROADWAY AND AT ANY OTHER INTERSECTION OR RESIDENTIAL ROADWAY.
- ① EASEMENT NOT REQUIRED IF ROAD IS ON THE SAME PARCEL AS FACILITY TO BE SERVED. EXISTING EASEMENTS OF LESS THAN 40' NEED NOT BE EXPANDED FOR THESE ROADS.
- ② BERM REQUIRED WHEN FILL HEIGHT EXCEEDS 10 FEET. BERM REQUIRED IN CUT AREAS.
- ③ 4 FOOT SHOULDER REQUIRED IN FILL AREAS.

NOT TO SCALE

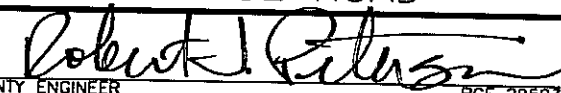
COUNTY OF NAPA DEPT. OF PUBLIC WORKS	
RURAL DRIVEWAY OR AGRICULTURAL SPECIAL PURPOSE ROAD	
 COUNTY ENGINEER	RCE 29593
MAY 2004	

district debt authorization, would make total County debt issuance eligible for the applicable small issuer arbitrage exemption rule?

I. Facilities eligible for funding through assessment financing

Facilities the construction of which may be financed through assessment proceedings are limited to public facilities located within dedicated rights-of-way or easements which the County or other local agency will be required to maintain and operate.

The types of facilities to be financed are:

- (a) Streets;
- (b) Drainage facilities;
- (c) Public utilities, whether privately or publicly owned, which are appurtenant and incidental to streets or which otherwise provide significant public benefit if not appurtenant or incidental to streets; and
- (d) Landscaping when used in conjunction with other public improvements listed above.

The above extract is included so as to provide an outline of the County's position. Full copies of the policy may be obtained from the Clerk of the Board of Supervisors.

24. PARCEL MAP IMPROVEMENTS – RESIDENTIAL DEVELOPMENT

Divisions of land by Parcel Map fall into three (3) general categories: (1) those adjacent to a county road, (2) on an existing private road, and (3) on a proposed new road which may be private or public. Road improvement requirements are as follows:

Case I – Adjacent to County Road

<u>Parcel Size</u>	<u>Improvement</u>
0 to less than ¼ acre	full improvements including curb, gutter and sidewalk as required for particular road and right of way dedication.
¼ to 2 acres	1. Widen existing road to provide a minimum 60' long parking lane per lot exclusive of driveways, or 2. Provide improved all weather surface in parking areas in accordance with County Standards for four cars per lot in addition to garage and carport, or 3. Provide 60 foot building setback from right of way line.



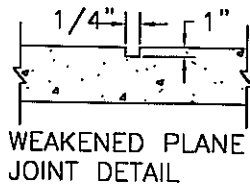

6" THICK CLASS B PORTLAND CEMENT CONCRETE  
 NO EXPANSION JOINTS WITHIN THIS AREA - USE  
 WEAKENED PLANE JOINTS @ 10'± INTERVALS

INSTALL 6"x6"x #10 WWF  
 WITHIN THESE LIMITS

SEE NOTE #1  
 WEAKENED PLANE JOINTS @ DRIVEWAYS & CURB RETURNS.

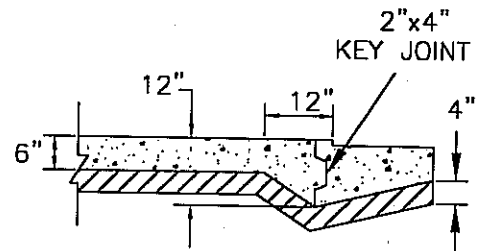
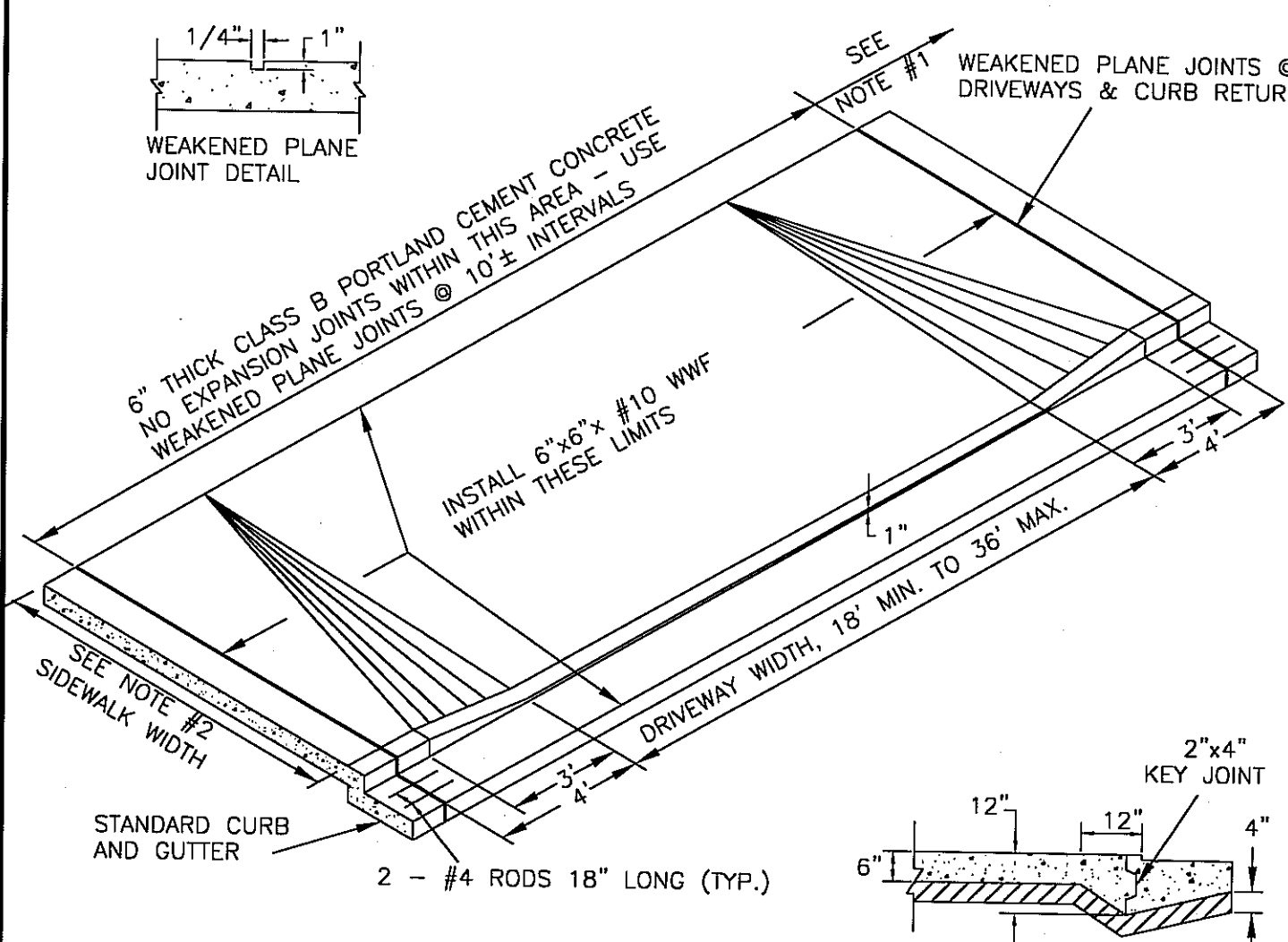

WHERE GUTTER AND DRIVEWAY APPROACH ARE POURED SEPARATELY ABOVE DETAIL SHALL APPLY.

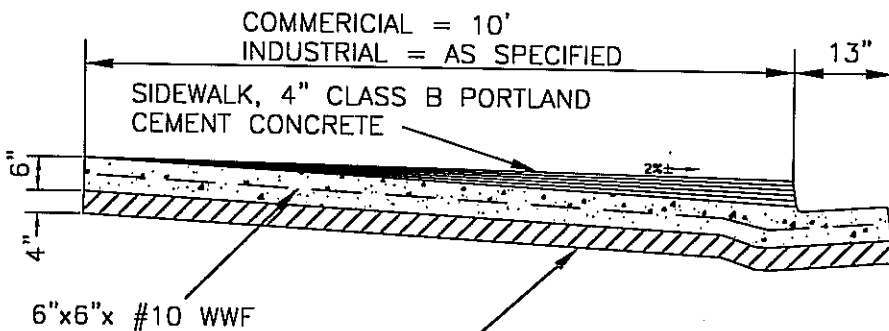

CLASS 2 AGGREGATE BASE OR APPROVED CLEAN GRANULAR MATERIAL, MIN. SAND EQUIVALENT OF 30.

NOTE:

1. MINIMUM DISTANCE TO INTERSECTION CURB RETURN SHALL BE 20' (SEE D-5).
2. SIDEWALK WIDTH AND LOCATION SHALL BE RELATIVE TO CURB.
3. INSTALL EXPANSION JOINTS @ 40' INTERVALS.

NOT TO SCALE

COUNTY OF NAPA DEPT OF PUBLIC WORKS	
COMMERCIAL & INDUSTRIAL DRIVEWAY & ADJOINING SIDEWALK	
<i>Robert J. Peterson</i>	
COUNTY ENGINEER	RCE 29593
APRIL 2004	

CLASS B PORTLAND  
CEMENT CONCRETE

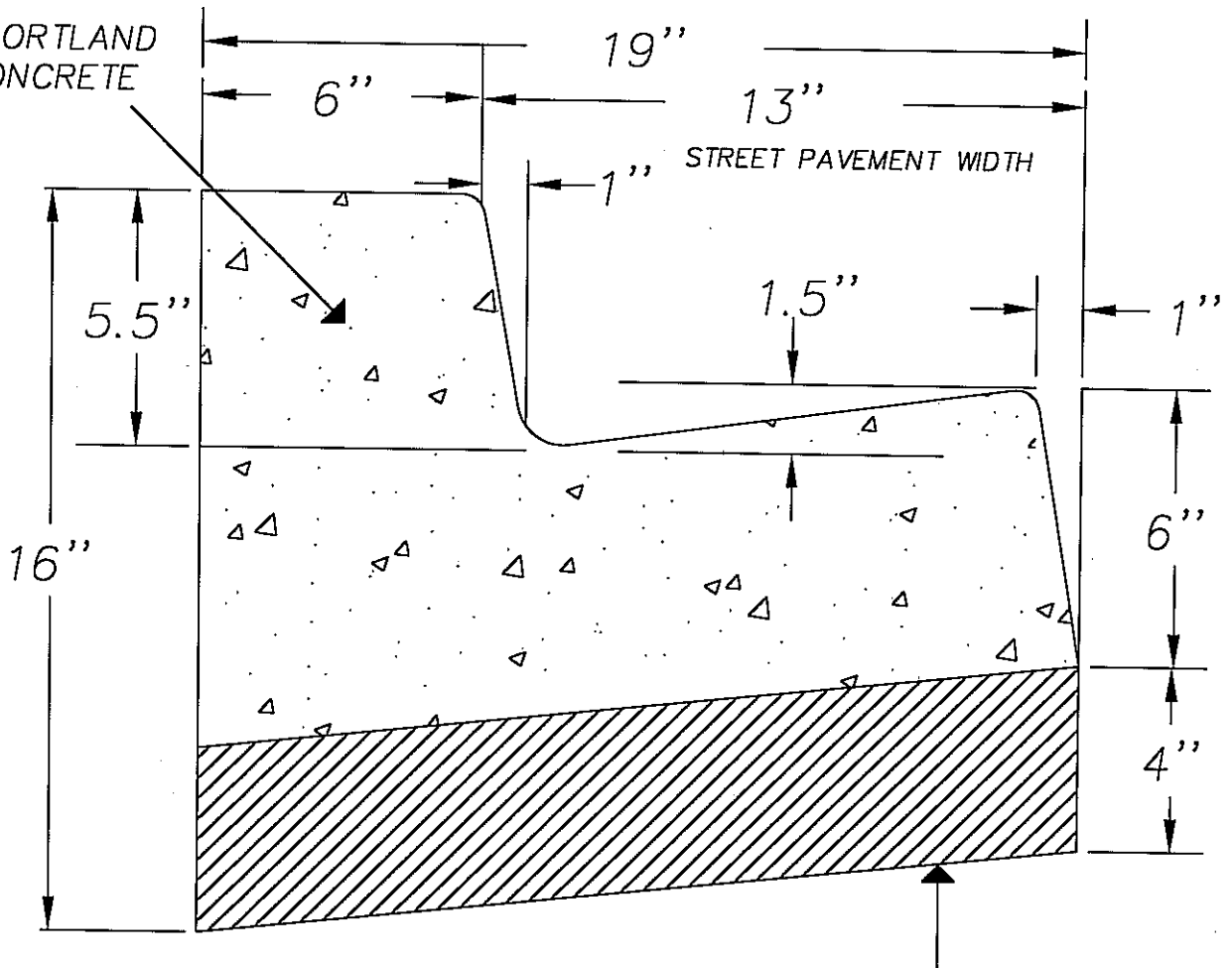

BASE FOR ALL CURBS AND MONOLITHIC  
CURB AND GUTTERS SHALL BE CLASS 2  
AGGREGATE BASE OR APPROVED CLEAN  
GRANULAR MATERIAL, MIN. SAND  
EQUIVALENT OF 30.

NOTE:

1. INSTALL WEAKENED PLANE JOINTS  
@ 10' INTERVALS.
2. INSTALL EXPANSION JOINTS @ 40'  
INTERVALS.

NOT TO SCALE

COUNTY OF NAPA  
DEPT OF PUBLIC WORKS

STANDARD VERTICAL  
CURB AND GUTTER

*Robert J. Pater*  
COUNTY ENGINEER RCE 29593

MAY 2004

NOTES:

1. TRANSITION TO VERTICAL CURB AT CURB RETURNS AND DRAINAGE STRUCTURES.
2. WEAKENED PLANE JOINTS @ 10 FEET.
3. EXPANSION JOINTS @ 50 FEET.

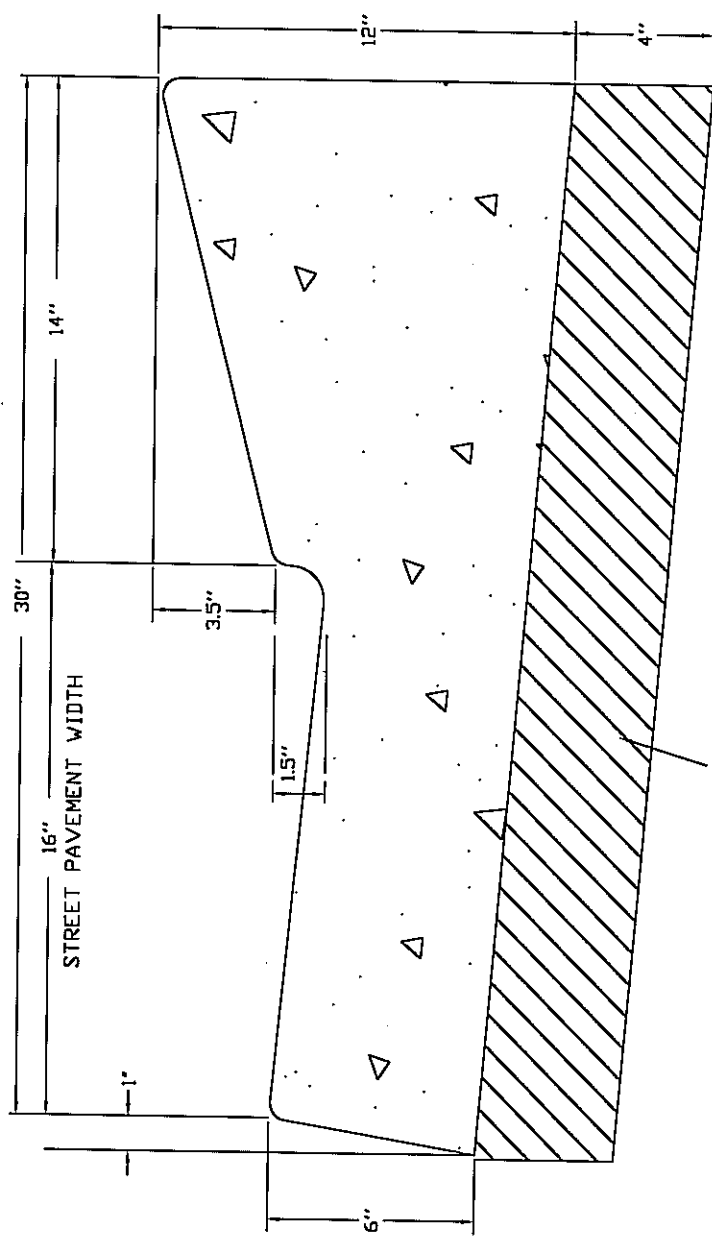
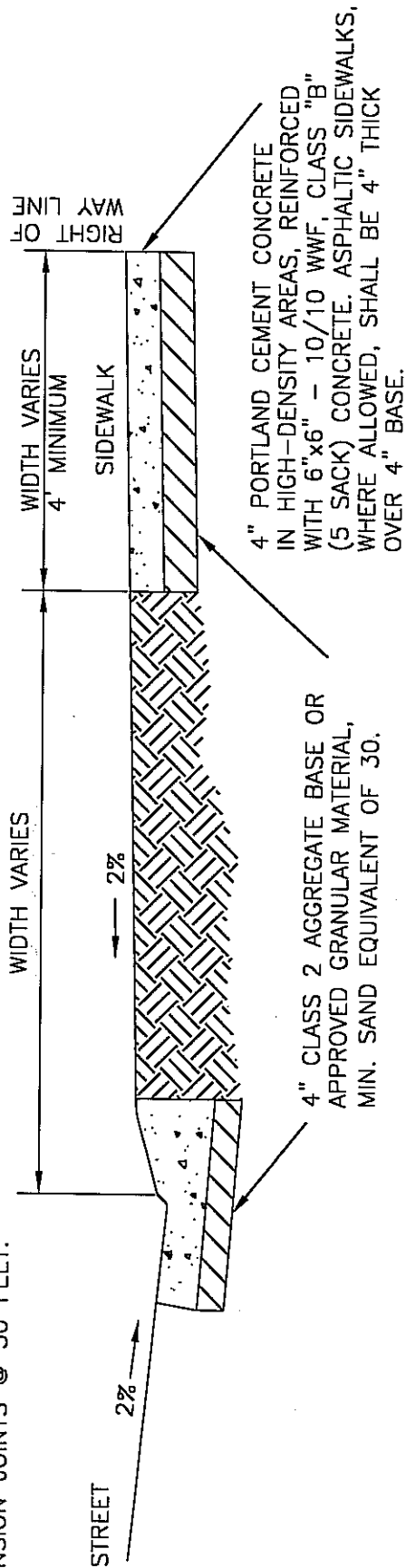

CLASS 2 AGGREGATE BASE OR APPROVED CLEAN GRANULAR MATERIAL, MIN. SAND EQUIVALENT OF 30

NOT TO SCALE

COUNTY OF NAPA  
DEPT. OF PUBLIC WORKS

MOUNTABLE CURB

*Robert J. Peters*  
COUNTY ENGINEER RCE 29593

MAY 2004

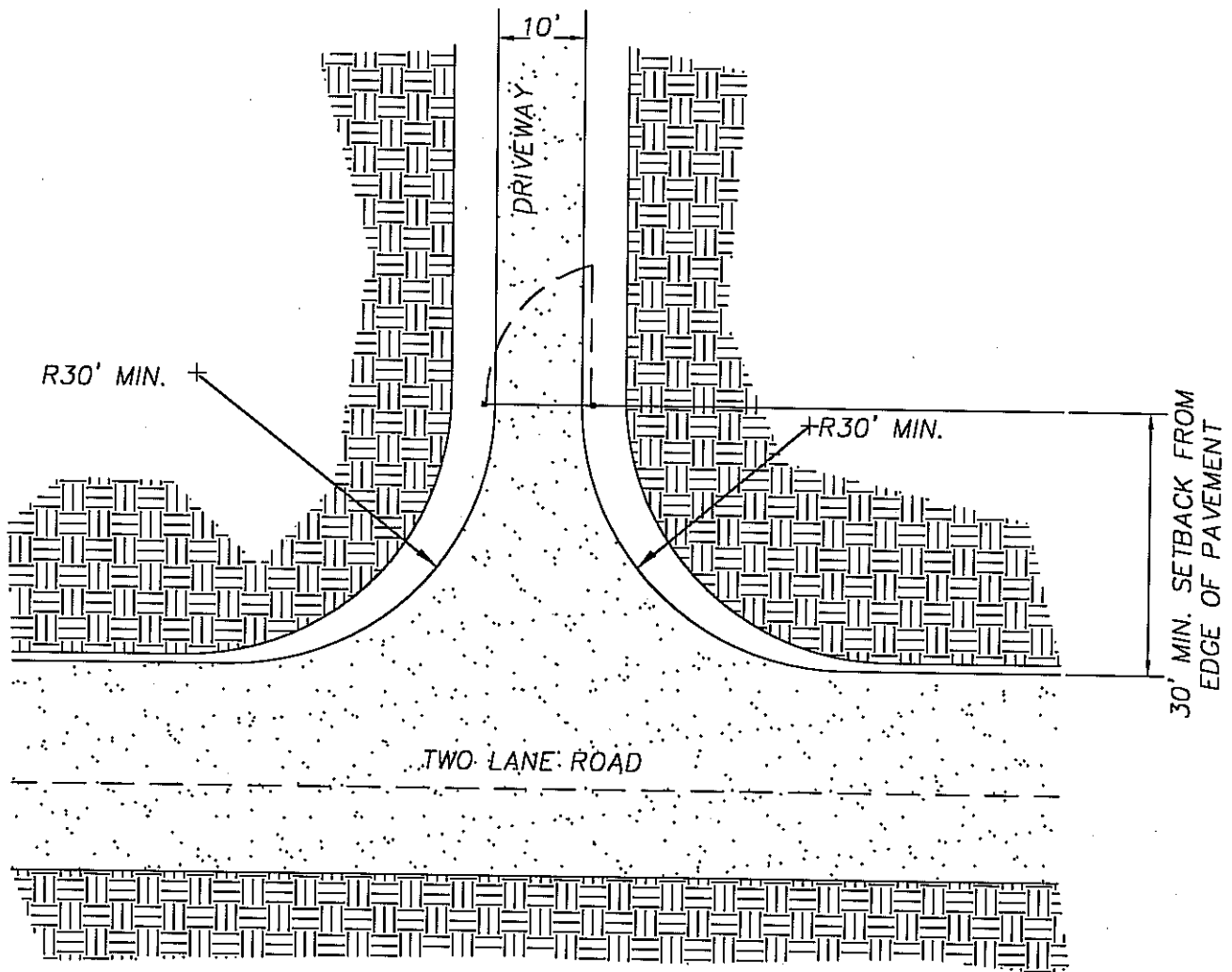

1. GATE ENTRANCE SHALL BE 2 FEET WIDER THAN THE WIDTH OF THE TRAFFIC LANE
2. GATES SHALL BE LOCATED 30 FEET MINIMUM FROM THE ROADWAY AND SHALL ALLOW A VEHICLE TO STOP WITHOUT OBSTRUCTING TRAFFIC
3. TURNING RADIUS SHALL NOT BE LESS THAN 30 FEET
4. ALL GATES SHALL HAVE FIRE DEPARTMENT APPROVED KEY ACCESS

NOT TO SCALE

COUNTY OF NAPA  
DEPT OF PUBLIC WORKS

GATED ENTRANCE

*Robert J. Peterson*  
COUNTY ENGINEER RCE 29593

May 2004

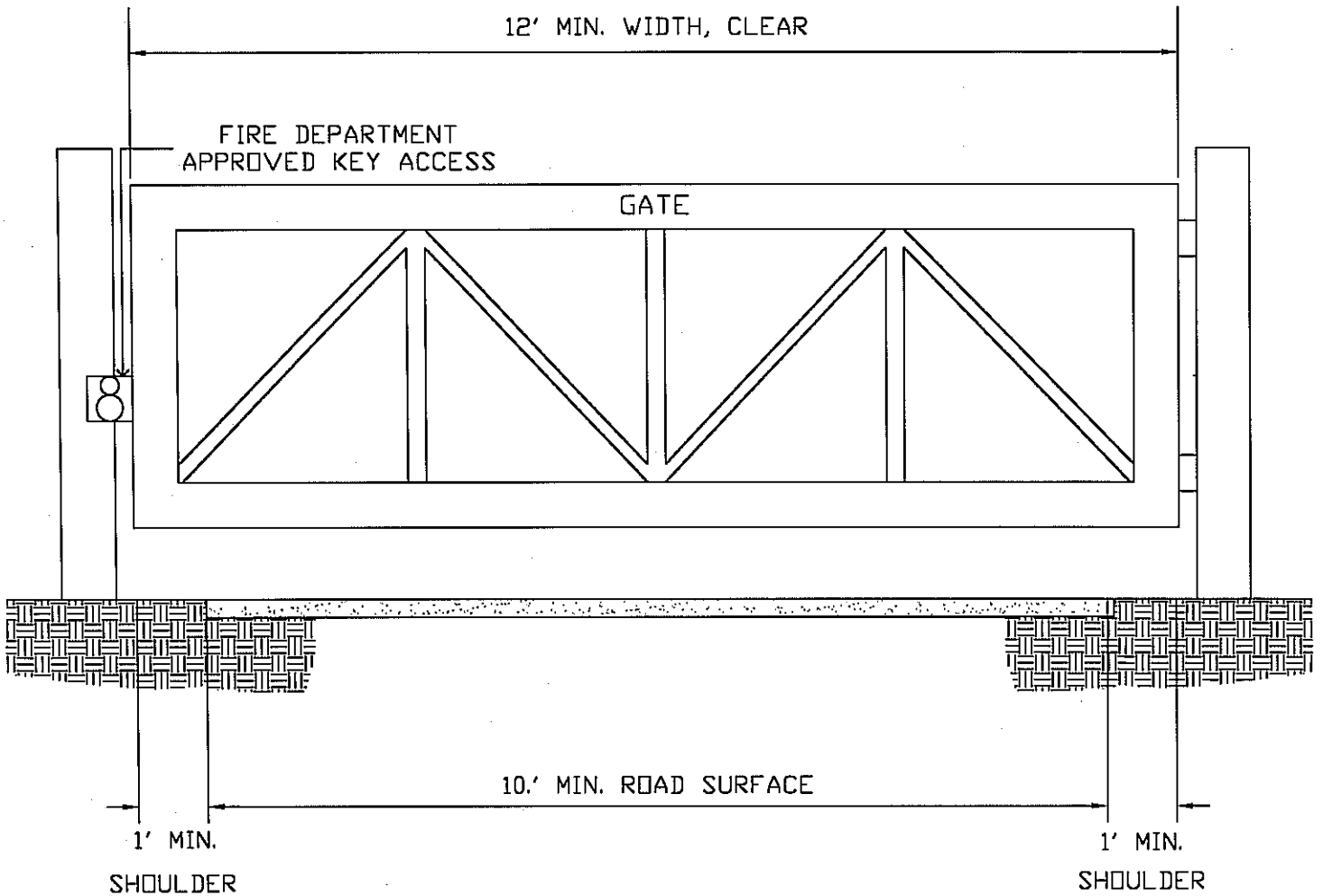

NOTE: GATE WIDTH SHALL BE NO LESS THAN WIDTH OF ROAD PLUS 1' SHOULDER, EACH SIDE OF ROAD

NOT TO SCALE

COUNTY OF NAPA  
DEPT OF PUBLIC WORKS

ENTRY GATE

*Robert J. Palmer*

COUNTY ENGINEER

RCE 29593

May 2004