

“B”

**Recommended Conditions of Approval
and Final Agency Approval Memos**

**ZONING ADMINISTRATOR HEARING – SEPTEMBER 22, 2021
RECOMMENDED CONDITIONS OF APPROVAL**

**Amizetta Winery - Small Winery Exemption Use Permit, Exception to the Road & Street
Standards, and Variance
Application Numbers P19-00132-UP and P21-00221-VAR
1089 Greenfield Road, St. Helena
APN 025-390-010**

This permit encompasses and shall be limited to the project commonly known as Amizetta Winery, located at 1089 Greenfield Road, St. Helena. Part I encompasses the Project Scope and general conditions pertaining to statutory and local code references, project monitoring, and the process for any future changes or activities. Part II encompasses the ongoing conditions relevant to the operation of the project. Part III encompasses the conditions relevant to construction and the prerequisites for a Final Certificate of Occupancy. It is the responsibility of the permittee to communicate the requirements of these conditions and mitigations (if any) to all designers, contractors, employees, and guests of the winery to ensure compliance is achieved.

Where conditions are not applicable or relevant to this project, they shall be noted as “Reserved” and therefore have been removed.

When modifying a legally established entitlement related to this project, these conditions are not intended to be retroactive or to have any effect on existing vested rights except where specifically indicated.

PART I

1.0 PROJECT SCOPE

The permit encompasses and shall be limited to:

- 1.1 Approval of a Variance to allow for the construction of an approximately 3,162 square foot winery structure to encroach 100 feet into the required 300 foot setback from existing access road.
- 1.2 An exception to the Napa County Road and Streets Standards (RSS), as detailed in the request prepared by Applied Civil Engineering, Inc., dated June 4, 2021, to allow reductions from the commercial driveway width standard (20.0 feet wide driveway) in locations throughout the existing driveway, as specified in the request, and an alternative emergency vehicle turnaround.
- 1.3 Approval to modify an existing 12,000 gallon per year winery previously approved under a Small Winery Exemption permit issued on May 18, 1984, to allow the following:
 - a. Increase annual wine production to 20,000 gallons;
 - b. Construct a new hospitality building and construct additions to the existing winery building to no more than 5,000 s.f. of total enclosed floor area, including a commercial kitchen;
 - c. Increase the area of the cave to no more than 5,000 s.f.;
 - d. New outdoor work and tasting areas;

- e. Five (5) full-time employees;
- f. Visitation, tours and tasting, and a marketing plan as set forth in Conditions of Approval (COAs) Nos. 4.1 through 4.3 below;
- g. On-premises consumption of wines produced on site in the tasting areas (indoor and outdoor) in accordance with Business and Professions Code Sections 23358, 23390 and 23396.5, as set forth in COA No. 4.4 below;
- h. Hours of operation from 7:00 a.m. to 5:00 p.m. Monday through Saturday for production and 10:00 a.m. to 6:00 p.m. Monday through Sunday for visitation;
- i. Provide 12 new parking spaces;
- j. Use of the existing cave for guided tours only (Type II);
- k. Installation of a 50,000 gallon water tank and new well; and,
- l. Upgrading/replacing the existing domestic/process wastewater treatment system.

The winery shall be designed in substantial conformance with the submitted site plan, elevation drawings, and other submittal materials and shall comply with all requirements of the Napa County Code (the County Code). It is the responsibility of the permittee to communicate the requirements of these conditions and mitigations (if any) to all designers, contractors, employees, and guests of the winery to ensure compliance is achieved. Any expansion or change in winery use or alternative locations for fire suppression or other types of water tanks shall be approved in accordance with the County Code and may be subject to the permit modification process.

2.0 STATUTORY AND CODE SECTION REFERENCES

All references to statutes and code sections shall refer to their successor as those sections or statutes may be subsequently amended from time to time.

3.0 MONITORING COSTS

All staff costs associated with monitoring compliance with these conditions, previous permit conditions, and project revisions shall be borne by the permittee and/or property owner. Costs associated with conditions of approval and mitigation measures that require monitoring, including investigation of complaints, other than those costs related to investigation of complaints of non-compliance that are determined to be unfounded, shall be charged to the property owner or permittee. Costs shall be as established by resolution of the Board of Supervisors in accordance with the hourly consulting rate established at the time of the monitoring and shall include maintenance of a \$500 deposit for construction compliance monitoring that shall be retained until issuance of a Final Certificate of Occupancy. Violations of conditions of approval or mitigation measures caused by the permittee's contractors, employees, and/or guests are the responsibility of the permittee.

The Planning Commission may implement an audit program if compliance deficiencies are noted. If evidence of a compliance deficiency is found to exist by the Planning Commission at some time in the future, the Planning Commission may institute the program at the applicant's expense (including requiring a deposit of funds in an amount determined by the Commission) as needed until compliance assurance is achieved. The Planning Commission may also use the data, if so warranted, to commence revocation proceedings in accordance with the County Code.

PART II

4.0 OPERATIONAL CHARACTERISTICS OF THE PROJECT

Permittee shall comply with the following during operation of the winery:

4.1 GENERAL PROVISIONS

Consistent with the County Code, tours and tastings and marketing may occur at a winery only where such activities are accessory and “clearly incidental, related, and subordinate to the primary operation of the winery as a production facility.”

Tours and tastings (defined below) may include food and wine pairings, where all such food service is provided without charge except to the extent of cost recovery and is incidental to the tasting of wine. Food service may not involve menu options and meal service such that the winery functions as a café or restaurant.

Retail sales of wine shall be permitted as set forth in the County Code.

4.2 TOURS AND TASTINGS/VISITATION

Tours and tastings shall be by appointment only and shall be limited to the following:

- a. Frequency: 7 days per week, Monday through Sunday
- b. Maximum number of persons per day: 30
- c. Maximum number of persons per week: 210
- d. Hours of visitation: 10:00 AM to 6:00 PM
- e. Wine and food pairings where food is provided by a licensed caterer or prepared on-site in a permitted commercial kitchen.

“Tours and tastings” means tours of the winery and/or tastings of wine, where such tours and tastings are limited to persons who have made unsolicited prior appointments for tours or tastings. To the maximum extent feasible, scheduling of visitors shall not occur during peak travel times 4:00 p.m. and 6:00 p.m.

A log book (or similar record) shall be maintained to document the number of visitors to the winery (for either tours and tastings or marketing events), and the dates of the visits. This record of visitors shall be made available to the Planning, Building and Environmental Services (PBES) Department upon request.

4.3 MARKETING

Marketing events shall be limited to the following:

- a. Marketing Event
 1. Frequency: Eight (8) times per year
 2. Maximum number of persons: 15
 3. Time of Day: 10:00 a.m. to 10:00 p.m.

- b. Marketing Event
 - 1. Frequency: Two (2) times per year
 - 2. Maximum number of persons: 25
 - 3. Time of Day: 10:00 am to 10:00 pm
- c. Tours and tastings authorized in COA No. 4.2, above, shall not occur during the same time as any marketing events.
- d. Marketing events shall be scheduled to occur outside of peak weekday and weekend (3:30 p.m. to 5:00 p.m.) traffic periods.
- e. Marketing events shall not occur upon issuance of a Red Flag Warning^[1] by the National Weather Service or Napa County Office of Emergency Services, or upon issuance of a Public Safety Power Shutoff (PSPS) Warning by Pacific Gas and Electric (PG&E), when such Warnings have been issued affecting any of the subject parcels of this use permit, including any parcels from which primary and secondary ingress/egress occurs. If Warnings are issued within Napa County, marketing events may take place only if the Project Parcels of this use permit are not located within the boundaries of the Warning order. If a marketing event is occurring at the time a Red Flag Warning or PSPS Warning is issued and takes effect, the event shall be terminated and all attendees and non-essential personnel shall be expeditiously directed off of the property.

"Marketing of wine" means any activity of a winery which is conducted at the winery on a prearranged basis for the education and development of customers and potential customers with respect to wine which can be sold at the winery on a retail basis pursuant to the County Code. Marketing of wine may include cultural and social events directly related to the education and development of customers and potential customers provided such events are clearly incidental, related and subordinate to the primary use of the winery. Marketing of wine may include food service, including food and wine pairings, where all such food service is provided without charge except to the extent of cost recovery.

Business events are similar to cultural and social events, in that they will only be considered as "marketing of wine" if they are directly related to the education and development of customers and potential customers of the winery and are part of a marketing plan approved as part of the winery's Use Permit. To be considered directly related to the education and development of customers or potential customers of the winery, business events must be conducted at no charge except to the extent of cost recovery, and any business content unrelated to wine must be limited.

Careful consideration shall be given to the intent of the event, the proportion of the business event's non-wine-related content, and the intensity of the overall marketing plan (County Code).

^[1] Red Flag Warnings are issued for weather events that may result in extreme fire behavior that will occur within 24 hours, to alert fire departments of the onset, or possible onset, of critical weather and dry conditions that could lead to rapid or dramatic increases in wildfire activity.

All marketing event activity, excluding quiet clean-up, shall cease by 10:00 p.m. If any event is held which will exceed the available on-site parking, the permittee shall prepare an event-specific parking plan which may include, but not be limited to, valet service or off-site parking and shuttle service to the winery.

Auction Napa Valley (ANV) events need not be included in a participating winery's marketing plan because they are covered by ANV's Category 5 Temporary Permit. The winery may utilize any ANV event authorized in this permit for another charitable event of similar size.

4.4 ON-PREMISES CONSUMPTION

In accordance with State law and the PBES Director's July 17, 2008 memo, "Assembly Bill 2004 (Evans) & the Sale of Wine for Consumption On-Premises," on-premises consumption of wine produced on-site and purchased from the winery may occur solely in the winery building and the surrounding paved/courtyard areas. Any and all visitation associated with on-premises consumption shall be subject to the maximum per person weekday and weekend daily tours and tastings visitation limitation and/or applicable limitations of permittee's marketing plan set forth in COA Nos. 4.2 and 4.3 above.

4.5 RESIDENCE OR NON-WINERY STRUCTURES

Unless specifically authorized by this permit or a previously approved permit, the existing single-family residence and uses and structures accessory to the residence shall not be used for commercial purposes or in conjunction with the operation and/or visitation/marketing program for the winery. If the residence is rented, it shall only be rented for periods of 30 days or more, pursuant to the County Code.

4.6 GRAPE SOURCE

At least 75% of the grapes used to make the winery's still wine or the still wine used by the winery to make sparkling wine shall be grown within Napa County provided that the winery's 12,000 gallons of production are not subject to the County's 75% grape source rule. The permittee shall keep records of annual production documenting the source of grapes to verify that 75% of the annual production is from Napa County grapes. The report shall recognize the Agriculture Commission's format for County of origin of grapes and juice used in the Winery Production Process. The report shall be provided to the PBES Department upon request, but shall be considered proprietary information and not available to the public.

4.7 COMPLIANCE REVIEW

Permittee shall obtain and maintain all permits (use permits and modifications) and licenses from the California Department of Alcoholic Beverage Control (ABC) and United States Tax and Trade Bureau (TTB), and California Department of Food and Agriculture (CDFA) Grape Crush Inquiry data, all of which are required to produce and sell wine. In the event the required ABC and/or TTB permits and/or licenses are suspended or revoked, permittee shall cease marketing events and tours and tastings until such time as those ABC and/or TTB permits and licenses are reinstated.

Visitation log books, visitor reports, custom crush client records, and any additional documentation determined by Staff to be necessary to evaluate compliance may be requested by the County for any code compliance. The permittee (and their successors) shall be required to participate fully in the winery code compliance review process.

4.8 RENTAL/LEASING

No winery facilities, or portions thereof, including, without limitation, any kitchens, barrel storage areas, or warehousing space, shall be rented, leased, or used by entities other than persons producing and/or storing wine at the winery, such as alternating proprietors and custom producers, except as may be specifically authorized in this Permit or pursuant to the Temporary Events Ordinance (County Code Chapter 5.36).

4.9 GROUND WATER MANAGEMENT – WELLS **[RESERVED]**

4.10 AMPLIFIED MUSIC

There shall be no amplified sound system or amplified music utilized outside of approved, enclosed, winery buildings.

4.11 TRAFFIC

To the maximum extent feasible, scheduling of reoccurring vehicle trips to and from the site for employees and deliveries shall not occur during peak travel times (4:00 to 6:00 p.m. on weekdays and 1:00 to 3:00 p.m. on Saturdays and Sundays). All road improvements on private property required per Engineering Services shall be maintained in good working condition and in accordance with the Napa County Roads and Streets Standards.

4.12 PARKING

The location of visitor parking and truck loading zone areas shall be identified along with proposed circulation and traffic control signage (if any).

Parking shall be limited to approved parking spaces only and shall not occur along access or public roads or in other locations except during harvest activities and approved marketing events. In no case shall parking impede emergency vehicle access or public roads.

4.13 BUILDING DIVISION – USE OR OCCUPANCY CHANGES

Please contact the Building Division with any questions regarding the following:

In accordance with the California Building Code (CBC), no change shall be made in the use of occupancy of an existing building unless the building is made to comply with the requirements of the current CBC for a new building.

4.14 FIRE DEPARTMENT – TEMPORARY STRUCTURES

Please contact the Fire Department with any questions regarding the following:

The permittee and/or designee shall obtain a tent permit from the Fire Department for any temporary structures utilized for authorized marketing events allowed per COA No. 4.3 above.

4.15 NAPA COUNTY MOSQUITO ABATEMENT PROGRAM **[RESERVED]**

4.16 GENERAL PROPERTY MAINTENANCE – LIGHTING, LANDSCAPING, PAINTING, OUTDOOR EQUIPMENT STORAGE, AND TRASH ENCLOSURE AREAS

- a. All lighting shall be permanently maintained in accordance with the lighting and building plans approved by the County. Lighting utilized during harvest activities is exempt from this requirement.
- b. All landscaping and outdoor screening, storage, and utility structures shall be permanently maintained in accordance with the landscaping and building plans approved by the County. No stored items shall exceed the height of the screening. Exterior winery equipment shall be maintained so as to not create a noise disturbance or exceed noise thresholds in the County Code.
- c. The colors used for the roof, exterior walls and built landscaping features of the winery shall be limited to earth tones that will blend the facility into the colors of the surrounding site specific vegetation. The permittee shall obtain the written approval of the Planning Division prior to any change in paint colors that differs from the approved building permit. Highly reflective surfaces are prohibited.
- d. Designated trash enclosure areas shall be made available and properly maintained for intended use.

4.17 NO TEMPORARY SIGNS

Temporary off-site signage, such as “A-Frame” signs, is prohibited.

4.18 COMPLIANCE WITH OTHER DEPARTMENTS AND AGENCIES – OPERATIONAL CONDITIONS

The attached project conditions of approval include all of the following County Divisions, Departments and Agencies’ requirements. Without limiting the force of those other requirements which may be applicable, the following are incorporated by reference as enumerated herein:

- a. Engineering Services Division operational conditions as stated in their Memorandum dated September 9, 2021.
- b. Environmental Health Division operational conditions as stated in their Memorandum dated June 25, 2021.
- c. Building Division operational conditions as stated in their Memorandum dated November 26, 2019.
- d. Department of Public Works operational conditions as stated in their Memorandum dated February 25, 2021.
- e. Fire Department operational conditions as stated in their Inter-Office Memo dated April 30, 2019.

The determination as to whether or not the permittee has substantially complied with the requirements of other County Divisions, Departments and Agencies shall be determined

by those County Divisions, Departments or Agencies. The inability to substantially comply with the requirements of other County Divisions, Departments and Agencies may result in the need to modify this permit.

4.19 OPERATIONAL MITIGATION MEASURES **[RESERVED]**

4.20 OTHER CONDITIONS APPLICABLE TO THE OPERATIONAL ASPECTS OF THE PROJECT

a. Groundwater Management Program

The parcels 025-390-010 and 025-390-011 shall be limited to 13.62 acre-feet of groundwater per year for all water consuming activities on the parcel during normal years and 5.48 acre-feet per year during designated drought years. A Groundwater Demand Management Program shall be developed and implemented for the property as outlined in COA 6.15(b) below.

In the event that changed circumstances or significant new information provide substantial evidence^[2] that the groundwater system referenced in the Use Permit would significantly affect the groundwater basin, the PBES Director shall be authorized to recommend additional reasonable conditions on the permittee, or revocation of this permit, as necessary to meet the requirements of the County Code and to protect public health, safety, and welfare.

b. Prior to commencement of operational changes of this use permit exception modification, including increasing production, employment and visitation levels, as well as holding marketing events, the applicant shall submit evidence to the Planning Division that all site improvements required by County Divisions included in these conditions are complete. Site improvements include: expanded wastewater system; roadway and driveway improvements.

c. All improvements required by the Code Compliance Division "Life Safety Issue" letter, dated July 2, 2019, as listed below, shall be completed prior to execution of any new entitlement or implementation of the recognized levels of operation approved under this permit.

1. **Building Code Compliance – Fermentation tanks**

Within 90 days of approval of this permit, secure all metal fermenting tanks by bolting them down or other acceptable (per building code) means of connection or submit an application for a building permit to remodel the existing winery building.

^[2]Substantial evidence is defined by case law as evidence that is of ponderable legal significance, reasonable in nature, credible and of solid value. The following constitute substantial evidence: facts, reasonable assumptions predicated on facts; and expert opinions supported by facts. Argument, speculation, unsubstantiated opinion or narrative, or clearly inaccurate or erroneous information do not constitute substantial evidence.

2. **Building Code Compliance – Type I cave**

The cave cannot be used for anything other than storage until approval of a building permit and a certificated of occupancy is granted.

4.21 PREVIOUS CONDITIONS [RESERVED]

PART III

5.0 PREREQUISITE FOR ISSUANCE OF PERMITS

5.1 PAYMENT OF FEES

No building, grading or sewage disposal permits shall be issued or other permits authorized until all accrued planning permit processing fees have been paid in full. This includes all fees associated with plan check and building inspections, associated development impact fees established by County Ordinance or Resolution, and the Napa County Affordable Housing Mitigation Fee in accordance with County Code.

6.0 GRADING/DEMOLITION/ENVIRONMENTAL/BUILDING PERMIT/OTHER PERMIT PREREQUISITES

Permittee shall comply with the following with the submittal of a grading, demolition, environmental, building and/or other applicable permit applications.

6.1 COMPLIANCE WITH OTHER DEPARTMENTS AND AGENCIES – PLAN REVIEW, CONSTRUCTION AND PREOCCUPANCY CONDITIONS

The attached project conditions of approval include all of the following County Divisions, Departments and Agencies' requirements. The permittee shall comply with all applicable building codes, zoning standards, and requirements of County Divisions, Departments and Agencies at the time of submittal and may be subject to change. Without limiting the force of those other requirements which may be applicable, the following are incorporated by reference as enumerated herein:

- a. Engineering Services Division plan review/construction/ preoccupancy conditions as stated in their Memorandum dated September 9, 2021.
- b. Environmental Health Division plan review/construction/ preoccupancy conditions as stated in their Memorandum dated June 25, 2021.
- c. Building Division plan review/construction/ preoccupancy conditions as stated in their Memorandum dated November 26, 2019.
- d. Department of Public Works plan review/construction/ preoccupancy conditions as stated in their Memorandum dated February 25, 2021.
- e. Fire Department plan review/construction/ preoccupancy conditions as stated in their Inter-Office Memo dated April 30, 2019.

The determination as to whether or not the permittee has substantially complied with the requirements of other County Divisions, Departments and Agencies shall be determined by those County Divisions, Departments or Agencies. The inability to substantially

comply with the requirements of other County Divisions, Departments and Agencies may result in the need to modify the permit.

6.2 BUILDING DIVISION – GENERAL CONDITIONS

- a. A building permit shall be obtained for all construction occurring on the site not otherwise exempt by the California Building Code (CBC) or any State or local amendment adopted thereto.
- b. If there are any existing structures and/or buildings on the property that will need to be removed to accommodate construction activities, a separate demolition permit shall be required from the Building Division prior to removal. The permittee shall provide a “J” number from the Bay Area Air Quality Management District (BAAQMD) at the time the permittee applies for a demolition permit if applicable.
- c. All areas of newly designed and newly constructed buildings, facilities and on-site improvements must comply with the CBC accessibility requirements, as well as, American with Disability Act requirements when applicable. When alterations or additions are made to existing buildings or facilities, an accessible path of travel to the specific area of alteration or addition shall be provided as required per the CBC.

6.3 LIGHTING – PLAN SUBMITTAL

- a. Two (2) copies of a detailed lighting plan showing the location and specifications for all lighting fixtures to be installed on the property shall be submitted for Planning Division review and approval. All lighting shall comply with the CBC.
- b. All exterior lighting, including landscape lighting, shall be shielded and directed downward, shall be located as low to the ground as possible, shall be the minimum necessary for security, safety, or operations; on timers; and shall incorporate the use of motion detection sensors to the greatest extent practical. All lighting shall be shielded or placed such that it does not shine directly on adjacent properties or impact vehicles on adjacent streets. No flood-lighting or sodium lighting of the building is permitted, including architectural highlighting and spotting. Low-level lighting shall be utilized in parking areas as opposed to elevated high-intensity light standards. Lighting utilized during harvest activities is exempt from this requirement.

6.4 LANDSCAPING – PLAN SUBMITTAL

- a. Two (2) copies of a detailed final landscaping and irrigation plan, including parking details, shall be submitted with the building permit application package for the Planning Division’s review and approval prior to the issuance of any building permit associated with this Use Permit. The plan shall be prepared pursuant to the County’s Water Efficient Landscape Ordinance (Chapter 18.118 of the County Code) requirements in effect at the time of building permit application submittal, as applicable, and shall indicate the names and locations of all plant materials to be used along with their method of maintenance.

- b. Plant materials shall be purchased locally when practical, and to the greatest extent possible, the plant materials shall be the same native plants found in Napa County. The Agricultural Commissioner's office shall be notified of all impending deliveries of live plants with points of origin outside of Napa County.
- c. No trees greater than 6" diameter at breast height shall be removed, except for those identified on the submitted site plan. Any Oak trees removed as a result of the project shall be replaced at a 2:1 ratio and shown on the landscaping plans for the Planning Division's review and approval. Trees to be retained shall be protected during construction by fencing securely installed at the outer most dripline of the tree or trees. Such fencing shall be maintained throughout the duration of the work undertaken in connection with the winery development/construction. In no case shall construction material, debris or vehicles be stored in the fenced tree protection area.
- d. Evergreen screening shall be installed between the industrial portions of the operation (e.g. tanks, crushing area, parking area, etc.) and any off-site residence from which these areas can be viewed.

6.5 COLORS

The colors used for the roof, exterior walls and built landscaping features of the winery shall be limited to earth tones that will blend the facility into the colors of the surrounding site specific vegetation. The permittee shall obtain the written approval of the Planning Division in conjunction with building permit review and/or prior to painting the building. Highly reflective surfaces are prohibited.

6.6 OUTDOOR STORAGE/SCREENING/UTILITIES

- a. Details of outdoor storage areas and structures shall be included on the building and landscape plans. All outdoor storage of winery equipment shall be screened from the view of residences of adjacent properties by a visual barrier consisting of fencing or dense landscaping. No stored item shall exceed the height of the screening. Water and fuel tanks, and similar structures, shall be screened to the extent practical so as to not be visible from public roads and adjacent parcels.
- b. New utility lines required for this project that are visible from any designated scenic transportation route (see Community Character Element of the General Plan and the County Code) shall be placed underground or in an equivalent manner be made virtually invisible from the subject roadway.
- c. Exterior winery equipment shall be located, enclosed or muffled so as not to exceed noise thresholds in the County Code.

6.7 TRASH ENCLOSURES

Adequate area must be provided for collection and loading of garbage and recyclables generated by the project. The applicant must work with the franchised garbage hauler for the service area in which they are located, in order to determine the area and the pedestrian and vehicle access needed for the collection site. The garbage and recycling

enclosure shall meet the minimum enclosure requirements established by staff and the franchised hauler, which shall be included in the building permit submittal.

6.8 ADDRESSING

All project site addresses shall be determined by the PBES Director, and be reviewed and approved by the United States Post Office. The PBES Director reserves the right to issue or re-issue an appropriate situs address at the time of issuance of any building permit to ensure proper identification and sequencing of numbers. For multi-tenant or multiple structure projects, this includes building permits for later building modifications or tenant improvements.

6.9 HISTORIC RESOURCES **[RESERVED]**

6.10 DEMOLITION ACTIVITIES **[RESERVED]**

6.11 VIEWSHED – EXECUTION OF USE RESTRICTION **[RESERVED]**

6.12 PERMIT PREREQUISITE MITIGATION MEASURES **[RESERVED]**

6.13 PARCEL CHANGE REQUIREMENTS **[RESERVED]**

6.14 FINAL MAPS **[RESERVED]**

6.15 OTHER CONDITIONS APPLICABLE TO THE PROJECT PERMITTING PROCESS

a. Groundwater Demand Management Program

1. The permittee shall install a meter on each well serving parcels 025-390-010 and 025-390-011. Each meter shall be placed in a location that will allow for the measurement of all groundwater used on the parcels. Prior to the issuance of a grading or building permit for the winery or expanding any operations as approved under this permit, the permittee shall submit for review and approval by the Director of Public Works and the Director of PBES a groundwater demand management plan which includes a plan for the location and the configuration of the installation of a meter on all wells serving the parcels.
2. The Plan shall identify how best available technology and best management water conservation practices will be applied throughout the parcels.
3. The Plan shall identify how best management water conservation practices will be applied where possible in the structures on site. This includes but is not limited to the installation of low flow fixtures and appliances.
4. As a groundwater consuming activity already exists on the parcels, meter installation and monitoring shall begin immediately and the first monitoring report is due to the County within 120 days of approval of this permit.

5. For the first twelve months of operation under this permit, the permittee shall read the meters at the beginning of each month and provide the data to the Public Works Director and the Director of PBES monthly. If the water usage on the property exceeds, or is on track to exceed, 13.62 acre-feet per year during normal years or 5.48 acre-feet per year during designated drought years, or if the permittee fails to report, additional reviews and analysis and/or a during drought years corrective action program at the permittee's expense shall be required and shall be submitted to the Public Works Director and the PBES Director for review and action.
6. The permittee's wells shall be included in the Napa County Groundwater Monitoring program if the County finds the well suitable.
7. At the completion of the reporting period per 6.15(b)(5) above, and so long as the water usage is within the maximum acre-feet per year as specified above, the permittee may begin the following meter reading schedule:
 - i. On or near the first day of each month the permittee shall read the water meter, and provide the data to the Public Works Director and the Director of PBES during the first weeks of April and October. The Public Works Director and the Director of PBES, or the Director's designated representative, has the right to access and verify the operation and readings of the meters during regular business hours.

7.0 PROJECT CONSTRUCTION

Permittee shall comply with the following during project construction:

7.1 SITE IMPROVEMENTS

Please contact Engineering Services with any questions regarding the following.

- a. **GRADING AND SPOILS**
All grading and spoils generated by construction of the project facilities shall be managed per Engineering Services direction. Alternative locations for spoils are permitted, subject to review and approval by the PBES Director, when such alternative locations do not change the overall concept, and do not conflict with any environmental mitigation measures or conditions of approval.
- b. **DUST CONTROL**
Water and/or dust palliatives shall be applied in sufficient quantities during grading and other ground disturbing activities on-site to minimize the amount of dust produced. Outdoor construction activities shall not occur when average wind speeds exceed 20 mph.
- c. **AIR QUALITY**
During all construction activities the permittee shall comply with the most current version of BAAQMD Basic Construction Best Management Practices including but not limited to the following, as applicable:

1. Post a publicly visible sign with the telephone number and person to contact at the lead agency regarding dust complaints. The BAAQMD's phone number shall also be visible.
2. Water all exposed surfaces (e.g., parking areas, staging areas, soil piles, grading areas, and unpaved access roads) two times per day.
3. Cover all haul trucks transporting soil, sand, or other loose material off-site.
4. Remove all visible mud or dirt traced onto adjacent public roads by using wet power vacuum street sweepers at least once per day. The use of dry power sweeping is prohibited.
5. All vehicle speeds on unpaved roads shall be limited to 15 mph.
6. All roadways, driveways, and sidewalks to be paved shall be completed as soon as possible. Building pads shall be laid as soon as possible after grading unless seeding or soil binders are used.
7. Idling times shall be minimized either by shutting off equipment when not in use or reducing the maximum idling time to five (5) minutes (as required by State Regulations). Clear signage shall be provided for construction workers at all access points.
8. All construction equipment shall be maintained and properly tuned in accordance with manufacturer's specifications. All equipment shall be checked by a certified visible emissions evaluator. Any portable engines greater than 50 horsepower or associated equipment operated within the BAAQMD's jurisdiction shall have either a California Air Resources Board (ARB) registration Portable Equipment Registration Program (PERP) or a BAAQMD permit. For general information regarding the certified visible emissions evaluator or the registration program, visit the ARB FAQ http://www.arb.ca.gov/portable/perp/perpfact_04-16-15.pdf or the PERP website <http://www.arb.ca.gov/portable/portable.htm>.

d. **STORM WATER CONTROL**

The permittee shall comply with all construction and post-construction storm water pollution prevention protocols as required by the County Engineering Services Division, and the California Regional Water Quality Control Board.

7.2 **ARCHEOLOGICAL FINDING**

In the event that archeological artifacts or human remains are discovered during construction, work shall cease in a 50-foot radius surrounding the area of discovery. The permittee shall contact the PBES Department for further guidance, which will likely include the requirement for the permittee to hire a qualified professional to analyze the artifacts encountered and to determine if additional measures are required.

If human remains are encountered during project development, all work in the vicinity must be halted, and the Napa County Coroner informed, so that the Coroner can determine if an investigation of the cause of death is required, and if the remains are of Native American origin. If the remains are of Native American origin, the permittee shall comply with the requirements of Public Resources Code Section 5097.98.

7.3 CONSTRUCTION NOISE

Construction noise shall be minimized to the greatest extent practical and feasible under State and local safety laws, consistent with construction noise levels permitted by the General Plan Community Character Element and the County Noise Ordinance. Construction equipment muffling and hours of operation shall be in compliance with the County Code. Equipment shall be shut down when not in use. Construction equipment shall normally be staged, loaded, and unloaded on the project site, if at all practicable. If project terrain or access road conditions require construction equipment to be staged, loaded, or unloaded off the project site (such as on a neighboring road or at the base of a hill), such activities shall only occur daily between the hours of 8 am to 5 pm.

7.4 CONSTRUCTION MITIGATION MEASURES [RESERVED]

7.5 OTHER CONSTRUCTION CONDITIONS APPLICABLE TO THE PROJECT PROPOSAL [RESERVED]

8.0 TEMPORARY CERTIFICATE OF OCCUPANCY - PREREQUISITES

A Temporary Certificate of Occupancy (TCO) may be granted pursuant to the County Code to allow the commencement of production activities prior to completion of all project improvements. Permittee shall comply with the following before a TCO is granted:

8.1 TEMPORARY OCCUPANCY

All life and safety conditions shall be addressed prior to issuance of a TCO by the County Building Official. TCOs shall not be used for the occupancy of hospitality buildings and shall not exceed the maximum time allowed by the County Code which is 180 days. Departments and/or agencies with jurisdiction over the project are authorized as part of the TCO process to require a security deposit or other financial instrument to guarantee completion of unfinished improvements.

9.0 FINAL CERTIFICATE OF OCCUPANCY – PREREQUISITES

Permittee shall comply with the following before a Final Certificate of Occupancy is granted by the County Building Official, which upon granting, authorizes all use permit activities to commence.

9.1 FINAL OCCUPANCY

All project improvements, including compliance with applicable codes, conditions, and requirements of all Departments and Agencies with jurisdiction over the project, shall be completed.

9.2 SIGNS

Detailed plans, including elevations, materials, color, and lighting for any winery identification or directional signs shall be submitted to the Department for administrative

review and approval prior to installation. Administrative review and approval is not required if signage to be installed is consistent with signage plans submitted, reviewed and approved as part of this permit approval. All signs shall meet the design standards as set forth in the County Code. At least one legible sign shall be placed at the property entrance with the words "Tours and Tasting by Prior Appointment Only" to inform the public of same. Any off-site signs allowed shall be in conformance with the County Code.

9.3 GATES/ENTRY STRUCTURES

Any gate installed at the winery entrance shall be reviewed by the PBES Department and the Fire Department to assure that the design allows large vehicles, such as motorhomes, to turn around if the gate is closed without backing into the public roadway, and that fire suppression access is available at all times. If the gate is part of an entry structure an additional permit shall be required pursuant to the County Code and in accordance with the Napa County Roads and Street Standards. A separate entry structure permit is not required if the entry structure is consistent with entry structure plans submitted, reviewed, and approved as part of this permit approval.

9.4 LANDSCAPING

Landscaping shall be installed in accordance with the approved landscaping plan.

9.5 ROAD OR TRAFFIC IMPROVEMENT REQUIREMENTS **[RESERVED]**

9.6 DEMOLITION ACTIVITIES **[RESERVED]**

9.7 GRADING SPOILS

All spoils shall be removed in accordance with the approved grading permit and/or building permit.

9.8 MITIGATION MEASURES APPLICABLE PRIOR TO ISSUANCE OF A FINAL CERTIFICATE OF OCCUPANCY **[RESERVED]**

9.9 OTHER CONDITIONS APPLICABLE PRIOR TO ISSUANCE OF A FINAL CERTIFICATE OF OCCUPANCY

- a. All required meters shall be installed and all groundwater usage monitoring required in COA 4.20(a) and 6.15(a) shall commence as specified in condition 6.15(a).



A Tradition of Stewardship
A Commitment to Service

Planning, Building & Environmental Services

1195 Third Street, Suite 210
Napa, CA 94559
www.countyofnapa.org

David Morrison
Director

MEMORANDUM

To: Sean Trippi, Planning	From: Jeannette Doss, Engineering <i>JP</i>
Date: September 9, 2021	Re: Amizetta Family Estate Wines Use Permit Modification Engineering CoA 1089 Greenfield Road, St. Helena, CA P19-00132 APN 025-390-010-000

The Engineering Division received a referral for comment on a modification to an existing use permit. Based upon the information provided in the application, Engineering finds the application **complete** and recommends the following conditions of approval:

EXISTING CONDITIONS

1. Napa County parcel 025-390-010-000 is located on a private driveway approximately 0.35 miles off of Greenfield Road (Public Local Road)
2. The winery driveway connection to Greenfield Road (Public Local Road) is approximately 1.6 miles from the from the connection with Conn Valley Road (Local Collector Road).
3. The existing parcel is approximately 21.47 acres.
4. Site is currently developed with a winery, associated winery accessory structures and site improvements, and vineyards.

RECOMMENDED APPROVAL CONDITIONS:

OPERATIONAL CHARACTERISTICS

1. Should any existing outdoor/uncovered loading/unloading areas and/or processing areas, including but not limited to wine grape crushing/pressing, juice fermentation, blending and fining, filtration and bottling, be modified, expanded and/or improved in the future, Napa County may require these areas to be paved and performed undercover.

2. The facility is designated as a discharger that discharges stormwater associated with industrial activity to waters of the United States. Therefore, the facility shall maintain or apply for coverage under the State Water Resources Control Board's Industrial General Permit (IGP), including meeting all applicable provision and protocols of the IGP. If the facility fails to meet the discharge prohibitions of the IGP, Napa County may require the facility to make the necessary improvements to eliminate all exposures to stormwater of the pollutant(s) for which the water body is impaired.
3. All required and/or proposed roadway, access drive, and parking area improvements shall be completed **prior to the execution** of any entitlements approved by this application.

PREREQUISITES FOR ISSUANCE OF PERMITS

4. The property owner shall obtain a grading permit for any proposed or required roadway and site improvements.
5. Prior to issuance of a building and/or grading permit, the owner shall demonstrate on the plans that all roadways, access driveways, and parking areas will be improved to meet the requirements as outlined in the latest edition of the Napa County Road & Street Standards for Commercial development at the time of approval of this application.
6. **Prior to issuance of a building or grading permit** the owner shall demonstrate on the plans that all roadway construction associated with this application shall conform to the Road Exception Evaluation composed by this Division, dated September 9, 2021 and enclosed herein, and per the accepted construction and inspection practices defined in Federal, State and Local codes. Any roadway, proposed new or reconstructed, not included in the above mentioned Road Exception Evaluation shall meet the requirements for a Commercial Driveway as outlined in the 2021 Napa County Road and Street Standards (RSS) {Resolution 2020-133}.
7. All on site civil improvements including but not limited to the excavation, fill, general grading, drainage, curb, gutter, surface drainage, storm drainage, parking and drive isles, shall be constructed according to plans prepared by a registered civil engineer, which will be reviewed and approved by the Engineering Division of the Napa County Planning, Building, and Environmental Services Department (PBES) **prior to the commencement** of any on site land preparation or construction. Plans shall be wet signed and submitted with the building and grading permit documents at the time of permit application. A plan check fee will apply.
8. Grading and drainage improvements shall be constructed according to the current Napa County Road and Street Standards, Chapter 16.28 of the Napa County Code, and Appendix J of the California Building Code.
9. **Prior to issuance of a building permit and/or grading permit** the owner shall submit the necessary documents for Erosion Control as determined by the area of disturbance of the proposed development in accordance with the Napa Countywide Stormwater Pollution Prevention program Erosion and Sediment Control Plan Guidance for Applicant and Review Staff dated December 2014.

10. **Prior to issuance of a building and/or grading permit** the owner shall prepare a Stormwater Control Plan (SCP) in accordance with the latest edition of the BASMAA Post-Construction Manual for review and approval by the Engineering Division in PBES.
11. **Prior to issuance of a building and/or grading permit**, an Operation and Maintenance Plan shall be submitted and tentatively approved by the Engineering Division in PBES. **Before final occupancy** the property owner must legally record the “Operation and Maintenance Agreement”, approved by the Engineering Division in PBES.

PREREQUISITES FOR TEMPORARY CERTIFICATE OF OCCUPANCY

12. All roadway, access drive, and parking area improvements shall be completed **prior to** issuance of temporary occupancy of any new and/or remodeled structures.

**** If no temporary occupancy is requested, then the above become requirements prior to final occupancy.**

PREREQUISITES FOR FINAL CERTIFICATION OF OCCUPANCY

13. Operations and Maintenance Agreement for any required post-construction Stormwater facilities must be legally recorded.
14. Site shall be completely stabilized to the satisfaction of the County Engineer prior to Final Occupancy.

Any changes in use may necessitate additional conditions for approval.

If you have any questions regarding the above items, please contact Jeannette Doss from Napa County Planning, Building, and Environmental Services Department, Engineering and Conservation Division, at (707) 259-8179 or by email at Jeannette.Doss@countyofnapa.org



A Tradition of Stewardship
A Commitment to Service

Planning, Building & Environmental Services

1195 Third Street, Suite 210
Napa, CA 94559
www.countyofnapa.org

David Morrison
Director

MEMORANDUM

To: Sean Trippi, Planning	From: Jeannette Doss, Engineering <i>JD</i>
Date: September 9, 2021	Re: Amizetta Family Estate Wines Evaluation of Napa County Road and Street Standards Exception Request 1089 Greenfield Road, St. Helena, CA P19-00132 APN 025-390-010-000

Road Modification Request

The Engineering Division received a request (the request) dated June 4, 2021 for an exception to the commercial driveway design criteria as outlined in the Napa County Road and Street Standards (RSS) as part of a Use Permit Modification and Variance application for an existing winery. Access to the subject property is off of Greenfield Road via a long private shared driveway. Beginning at Greenfield Road to the terminus at the Amizetta Family Estate Wines site the existing driveway varies in width from 10 feet to 11 feet and is approximately 1,848 feet in length. The nature and constraints for the road exception are to minimize environmental impacts by reducing earth disturbances on steep slopes, proximity to natural water courses, and preserving heritage trees. The details of the request are as follows:

EXCEPTION #1 ROADWAY WIDTH EXCEPTION:

The request is for selective narrowing of the roadway in order to preserve natural features of the environment. At the road stations identified below the driveway is flanked by steep slopes on the uphill and downhill side of the roadway, natural watercourses, and several large native mature trees that vary in diameter from 6 inches to 24 inches or more in diameter breast height. Due to the constraints noted above the applicant cannot improve the driveway to fully comply with the RSS width requirements. The applicant is proposing to widen driveway to maximum road width achievable in these areas and provide full improvement in the areas not listed.

- STA 3+40 to 5+50 – A 210 foot linear section of roadway widened to maximum extent practical with a minimum paved width of 14 feet.
- STA 5+75 to 9+75 – A 400 foot linear section of roadway widened to maximum extent practical with a minimum paved width of 11.0 feet. This section also includes maintenance of existing shoulder areas to create two inter-visible turnouts.

- STA 9+75 to 12+50 – A 275 foot linear section of roadway widened to maximum extent practical with a minimum paved width of 10 feet. This section also includes maintenance of an existing shoulder area to create a turnout.
- STA 13+00 to 14+00 – A 100 foot linear section of roadway that is currently approximately 10.0 feet wide. No additional widening is proposed due to the steep slopes on either side of this section.
- STA 14+00 to 15+50 – A 150 foot linear section of roadway widened to maximum extent practical with a minimum paved width of 14 feet.

EXCEPTION #2 ROADWAY TURNAROUND EXCEPTION:

This request also includes a request for the required emergency vehicle turnaround to be located slightly further than the required 50 feet maximum from the winery structure. The project has provided access to within 10 feet of the cave portal and building.

Engineering Division Evaluation and Recommendation:

Engineering Division staff has visited the site and discussed the request noted above with Cal Fire/Napa County Fire Department and the applicant. With respect to Section (3) of the RSS as adopted by Resolution No. 2020-133 by the Board of Supervisors on January 1, 2021, this division has determined the following:

- The exception request has provided the necessary documentation as required by RSS Section 3(A). The request is in connection with a Use Permit application for modification to an existing winery, and has received the appropriate environmental review from the Planning Division, therefore the approving body shall be the Planning Commission.
- The reduction in road width at the above identified road stations will minimize earthwork on slopes exceeding 30% in order to preserve the existing environmental features and are justified based upon existing topographic conditions of the site.
- With respect to the findings for compliance with current RSS, the trees defined above of at least 6 inch diameter breast height and steep slopes are consistent with the definition of unique features of the natural environment as described in RSS Section 3(D)(1).
- With respect to the findings for compliance with current RSS, the avoidance of earth disturbance within the stream setback the definition of unique features of the natural environment as described in RSS Section 3(D)(1). The Engineering Division along with Planning Division staff have discussed the constraints presented in the road exception request and find they meet the intent of RSS Section 3(D)(1) – preserving unique features of the natural environment.
- The applicant is proposing to improve and widen the travel lane to maximum extent practical over the entire length of the driveway.

- The proposed alternative turnaround area (not within 50 ft of the winery structure) has been shown to be able to support emergency apparatus and has been authorized by Cal Fire/Napa County Fire Department as proposed.
- With respect to the findings for compliance with current RSS Section 3(E), the Engineering and Conservation Division and Cal Fire/Napa County Fire Department have discussed the improvements proposed and determined that their implementation would serve as an alternate method by which adherence to the RSS may be achieved and would provide the same overall practical effect as the RSS towards providing defensible space, preserving the natural environment and protecting the life, safety and welfare of the public.

The Engineering Division supports the approval of the exception request as proposed with the following conditions that are in addition to any and all conditions previously placed on the project as part of the discretionary application:

1. The roadway shall be constructed and maintained to the approved condition prior to execution of any new entitlements approved under the associated Use Permit Modification and throughout the life of the parcel or until such time the County deems that future road design changes or changes in use of this roadway beyond the use proposed shall require re-evaluation of the roadway to comply with the requirements of adopted codes, standards and regulations and may require additional conditions.
2. Applicant shall improve the existing roadway to the maximum road width achievable to preserve the existing natural features.
3. Access road shall meet the road surfacing requirements as described in the RSS for the entire length of the roadway.
4. To ensure the upkeep of the paved surfaces, the private road surface shall be periodically maintained by the property owner to assure sufficient structural section for loading conditions to the imposed loads of fire apparatus weighing at least 75,000 pounds and the design Traffic Index.
5. The property owner will implement a horizontal and vertical vegetation management plan consistent with California Department of Forestry and Fire Protection requirements along the entire length of the driveway to provide defensive space and improve sight distance. The vegetation management plan shall be reviewed and approved by the Napa County Fire Marshal.
6. Any/all future road design changes or changes in use of this roadway beyond the existing use shown on the above noted request shall require re-evaluation of the roadway to comply with the requirements of adopted codes, standards and regulations and may require additional conditions.

EXHIBIT A

AMIZETTA FAMILY ESTATE WINES
ROAD EXCEPTION REQUEST AND IMPROVEMENT PLANS



March 18, 2019
June 21, 2019 – Revision #1
June 4, 2021 - Revision #2

Job No. 18-155

Mr. David Morrison, Director
Napa County Planning, Building and Environmental Services Department
1195 Third Street, Suite 210
Napa, California 94559

Re: Request for Exception to the Napa County Road and Street Standards for the
Amizetta Winery Use Permit Application
1089 Greenfield Road, St. Helena, CA
Napa County APN 025-390-010

Dear Mr. Morrison:

This request for an exception to the Napa County Road and Street Standards is being filed concurrent with the above referenced Use Permit application for Amizetta Winery. We are providing this information for your review and final decision by the Conservation, Development and Planning Commission pursuant to Section 3 of the Napa County Road and Street Standards. Section 3 allows exceptions to the Standards provided that the exception still provides the same overall practical effect as the Standards towards providing defensible space and consideration towards life, safety and public welfare and:

1. The exception will preserve unique features of the natural environment which includes, but is not limited to, natural watercourses, steep slopes, geological features, heritage oak trees, or other trees of at least 6" dbh and found by the decision maker to be of significant importance, but does not include man made environmental features such as vineyards, rock walls, ornamental or decorative landscaping, fences or the like;
2. The exception is necessary to accommodate physical site limitations such as grade differentials; and/or
3. The exception is necessary to accommodate other limiting factors such as recorded historical sites or legal constraints.

It is our opinion that approving the subject Use Permit along with the proposed driveway improvements and granting this exception will:

1. Reduce the removal of heritage oak and other mature native trees and vegetation;
2. Minimize the need for grading on the steep slopes;
3. Reduce potential impacts on municipal water supply by minimizing tree removal, grading and potential soil loss;
4. Provide the same overall practical effect as the Standards towards providing defensible space and consideration towards life, safety and public welfare; and
5. Improve emergency vehicle access to the subject property and the area in general compared to what exists today.

The remainder of this letter describes the proposed project, provides background information regarding existing access conditions, outlines the proposed driveway improvements, identifies specific areas where an exception to the Standards is being requested and provides justification for the requested exception.

Project Description

Amizetta Winery is applying for a Use Permit to modify their existing winery facility located at 1089 Greenfield Road in St. Helena, California. The winery facility currently operates under a small winery exemption.

The proposed Use Permit operational characteristics are outlined below:

Category	Proposed	Notes
Winery Production	20,000 gallons per year	
Employees	5 FT	
Tours and Tasting Visitors	30 / day	210 max per week
Events		
15 guests	8 / year	Food catered
25 guests	2 / year	Food catered

Existing structures on the winery property include winery buildings, a cave, a single-family residence and outbuildings. A new winery hospitality building will be constructed and the existing cave will be expanded as part of the proposed Use Permit.

Existing Access Road Conditions

Access to the Amizetta Winery is via a private driveway off Greenfield Road. The driveway provides access to the subject Amizetta Winery property as well as the adjacent property to the east that is developed with a single-family residence. Please refer to the Amizetta Winery Use Permit Conceptual Site Improvement Plans for illustrations of the existing driveway conditions that are outlined below.

The Amizetta Winery Driveway starts at a cul-de-sac at the end of the publicly maintained Greenfield Road. The driveway traverses roughly 0.35 miles from Greenfield Road to the winery site. Topography along the driveway varies and can generally be characterized as steeply sloping natural hillsides and terraced vineyards.

From STA 1+00 (Greenfield Road) to STA 16+00 the driveway is shared with the existing single family residence on the adjacent property. This segment of driveway is paved with asphalt to an average width of 10 to 11 feet. Longitudinal slopes vary and generally average less than 10% although some sections do have slopes up to 18%.

At STA 16+00 there is a wye in the road and the winery driveway diverges from the residential driveway that serves the adjacent property. The driveway now is used by the subject winery only. From this point at STA 16+00 to the winery site at STA 19+50 the driveway transitions to gravel paving with an average width of 10 to 11 feet. Longitudinal slopes vary and generally average 16 to 18% and some sections at the immediate approach to the winery site have slopes in excess of 20%.

Napa County Road and Street Standards Requirements

The Napa County Road and Street Standards require private access driveways serving wineries provide two (2) 10-foot-wide travel lanes (20 feet total), 22 feet of total horizontal clearance (including the travel lanes), 15 feet of vertical clearance, 50 foot minimum inside turning radius and a maximum 16% longitudinal slope (provisions are made to allow slopes up to 18% if paved with asphalt and up to 20% in certain circumstances if there are less sloping areas above and below the 20% section).

Proposed Driveway Improvements and Request for Exception to Napa County Road and Street Standards

Improving the existing private driveway to the full 20 foot width and 16-20% maximum slope along the entire length would require substantial grading on very steep slopes, within stream setbacks and removal of numerous native oak and other trees over 6" dbh.

While full compliance with the Standards is not feasible given the topographic and environmental constraints, we have identified several areas that can be improved to meet the Standards and other

improvements that can be made to improve access conditions in non-compliant areas. However, in order to minimize environmental impacts and preserve many existing mature trees along the roadway Amizetta Winery is requesting an exception to the Napa County Road and Street Standards in discrete locations to allow reduced driveway widths.

The summary below describes sections of the driveway that will be improved and areas that an exception is being requested for.

- | | |
|----------------------|--|
| STA 1+00 to 3+40 +/- | Remove and replace existing gate with new gate that provides 22 feet minimum clear opening. Widen existing driveway to provide 20 feet of paved width and 2 additional feet of horizontal clearance. No exception is requested for this area. |
| STA 3+40 to 5+75 | Transition driveway width and widen to maximum extent practical. Exception requested to allow reduced width due to very steep slopes and abrupt changes in elevation on both sides of driveway. |
| STA 5+50 | Install approximately 40 foot long by 24 foot wide turnout. |
| STA 5+75 to 9+75 | No additional widening proposed for this area. Exception requested to allow reduced width due to steep slopes and abrupt changes in elevation on both sides of driveway and to minimize earth disturbance within stream setbacks as this segment of driveway is located within the prescribed setback for the adjacent blue line stream. |
| STA 9+75 | Maintain existing wide shoulder area with new gravel and paving to maximum width practical (18' – 22' as noted on plans). |
| STA 9+75 to 11+50 | No additional widening proposed for this area. Exception requested to allow reduced width due to steep slopes and abrupt changes in elevation on both sides of driveway and to minimize earth disturbance within stream setbacks as this segment of driveway is located within the prescribed setback for the adjacent blue line stream. |
| STA 11+50 to 12+50 | Maintain existing shoulder with new gravel to maximum width practical. Exception requested to allow reduced width due to steep slopes and abrupt changes in elevation on both sides of driveway and to minimize earth disturbance within stream setbacks as this segment of driveway is located within the prescribed setback for the adjacent blue line stream. |
| STA 12+50 | Maintain existing wide shoulder area with new gravel as needed to create approximately 50 foot long by 26 foot wide turnout. No exception for width is requested at the location of the turnout. |

- STA 13+00 to 14+00 No additional widening proposed for this area. Exception requested to allow reduced width due to steep slopes and abrupt changes in elevation on both sides of driveway and to minimize earth disturbance within stream setbacks as a portion of this segment of driveway is located within the prescribed setback for the adjacent blue line stream. This segment of driveway is also constrained by mature heritage oak trees in close proximity to the driveway.
- STA 14+00 to 15+50 +/- Widen to maximum extent practical (14' +/-). Exception requested to allow reduced width due to steep slopes and abrupt changes in elevation on both sides of driveway.
- STA 15+50 to 19+50 Completely rebuild existing driveway to provide 20 feet of paved width and 2 additional feet of horizontal clearance and additional width as required for curves with radii less than 200'. No exception is requested for this area.
- STA 19+50 Create space for geometrically compliant fire truck turnaround. The turnaround will be located within 50 feet of the existing winery building and approximately 70 feet from the proposed new cave portal / building. An exception is being requested to allow the hammerhead to be more than 50 from the new cave portal due to steeply sloping topography and associated space constraints.

Justification of Exception

As previously described, Section 3.D. of the Napa County Road and Street Standards states that an exception to the Road and Street Standards may be granted if the exception will preserve unique features of the natural environment (including native trees, watercourses, steep slopes and geologic features) and the proposed project provides the same overall practical effect as the Standards towards providing defensible space, and consideration towards life, safety and public welfare.

The same overall practical effect as the Standards can be achieved in areas where an exception is being requested in the following ways:

- STA 3+40 to 5+50 This short stretch of driveway is completely visible from end to end. A vehicle approaching this segment of road from either direction can see the other end of the segment with reduced width and can therefore easily stop to let an oncoming vehicle pass before entering the segment with reduced width.
- STA 5+75 to 9+75 This segment of driveway is partially visible from end to end. With vegetation clearing along the east side of the driveway visibility can be improved so that a vehicle approaching this segment of road from either direction can see the other end of the segment with reduced width and can therefore easily stop and pull into a turnout area to let an oncoming vehicle

pass before continuing through the segment with reduced width.

STA 9+75 to 12+50

This segment of driveway is partially visible from end to end. With vegetation clearing along the east side of the driveway visibility can be improved so that a vehicle approaching this segment of road from either direction can see the other end of the segment with reduced width and can therefore easily stop and pull into a turnout area to let an oncoming vehicle pass before continuing through the segment with reduced width.

STA 13+00 to 15+50

This short stretch of driveway is completely visible from end to end. A vehicle approaching this segment of road from either direction can see the other end of the segment with reduced width and can therefore easily stop to let an oncoming vehicle pass before entering the segment with reduced width.

STA 19+50

The hammerhead will be slightly more than the prescribed 50 feet from the proposed cave portal and building. Emergency vehicles will be able to drive to within 10 feet of the portal and building though and therefore this configuration will provide equivalent access similar to if the hammerhead was within 50 feet of the building and portal.

In addition to the proposed substantial driveway improvements that will be constructed to improve ingress and egress to the subject property several other measures have been incorporated into the project design to provide the “same overall practical effect” as the Standards towards providing defensible space and consideration towards life, safety and public welfare. Below is a summary of the proposed measures:

Defensible Space

- I. Horizontal and vertical vegetation management will be implemented along the entire length of the existing driveway and around the existing and proposed structures on the subject property to create defensible space. This will include vegetation management and modification 10 feet horizontally and 15 feet vertically along all private access roads and 100 feet (or to the nearest property or easement line) around buildings in accordance with Napa County Fire Department requirements.

Life Safety and Public Welfare

1. Address signage for existing uses on the subject and adjacent properties will be upgraded as needed to comply with County Fire Department Standards to improve emergency vehicle accessibility.
2. A robust fire protection system will be installed as part of the project. This will include a large elevated water storage tank, a hydrant and fire sprinklers. The fire protection system will be installed in all new construction and also within the existing winery structures and cave.

Section 3.F. of the Standards specifically identifies that built in fire protection systems can be used to help achieve the same overall practical effect as the Standards towards providing defensible space, consideration of life, safety and public welfare and not compromising civilian access or Fire Department access.

Conclusions & Findings In Support of Exception Request

It is our opinion that this request to allow the existing access driveway to be approved with significant improvements and with segments that do not strictly comply with the Standards meets the criteria established in Section 3 of the Road and Street Standards. More specifically, approval of the proposed exception will:

1. Preserve mature native trees on steeply sloping hillsides;
2. Minimize the need for grading on very steep slopes and within stream setbacks;
3. Provide the same overall practical effect as the Standards towards providing defensible space and consideration towards life, safety and public welfare.

As previously described, there are mature native trees and steep hillside slopes along the existing driveway that are worthy of preservation. Portions of the existing driveway also lie within stream setbacks. It is important to preserve the natural character of the area by minimizing the amount of grading on steep slopes and within stream setbacks and to minimize tree removal. Not only do the trees and topography contribute to the rural character of the woodlands and watershed areas, they also provide shelter and habitat for a wide range of animal and plant species. This is especially important given the project's location within the Lake Hennessey municipal water supply watershed.

Preservation of these features can be achieved by allowing an exception to the Standards in the isolated areas previously described. The Applicant is willing to improve the existing driveway to the greatest extent practicable where it is beneficial while abiding by the limitations of the existing topographic and environmental constraints in order to minimize unnecessary grading on steep slopes and while preserving mature native trees and forest areas located along the driveway to the greatest extent possible. With the proposed improvements, proper vegetation management and regular maintenance, there is no reason that these environmental features cannot be preserved while still achieving the same overall practical effect as outlined in the Standards. Furthermore, the driveway conditions that will result from the proposed improvements will be significantly better

than what exists today and will therefore improve emergency vehicle access which is important to not only the property that is part of this application but the entire area in general.

We look forward to hearing from a representative from your department to discuss any questions that may arise during review of this request. Please contact us at (707) 320-4968 if you have any questions.

Sincerely,

Applied Civil Engineering Incorporated

By:

Michael R. Muelrath

Michael R. Muelrath, R.C.E. 67435
Principal



Copy:

Perry Clark, Amizetta Winery (via email)
Jeff Redding (via email)

Enclosures:

Amizetta Winery Use Permit Conceptual Site Improvement Plans

AMIZETTA WINERY

USE PERMIT CONCEPTUAL SITE IMPROVEMENT PLANS

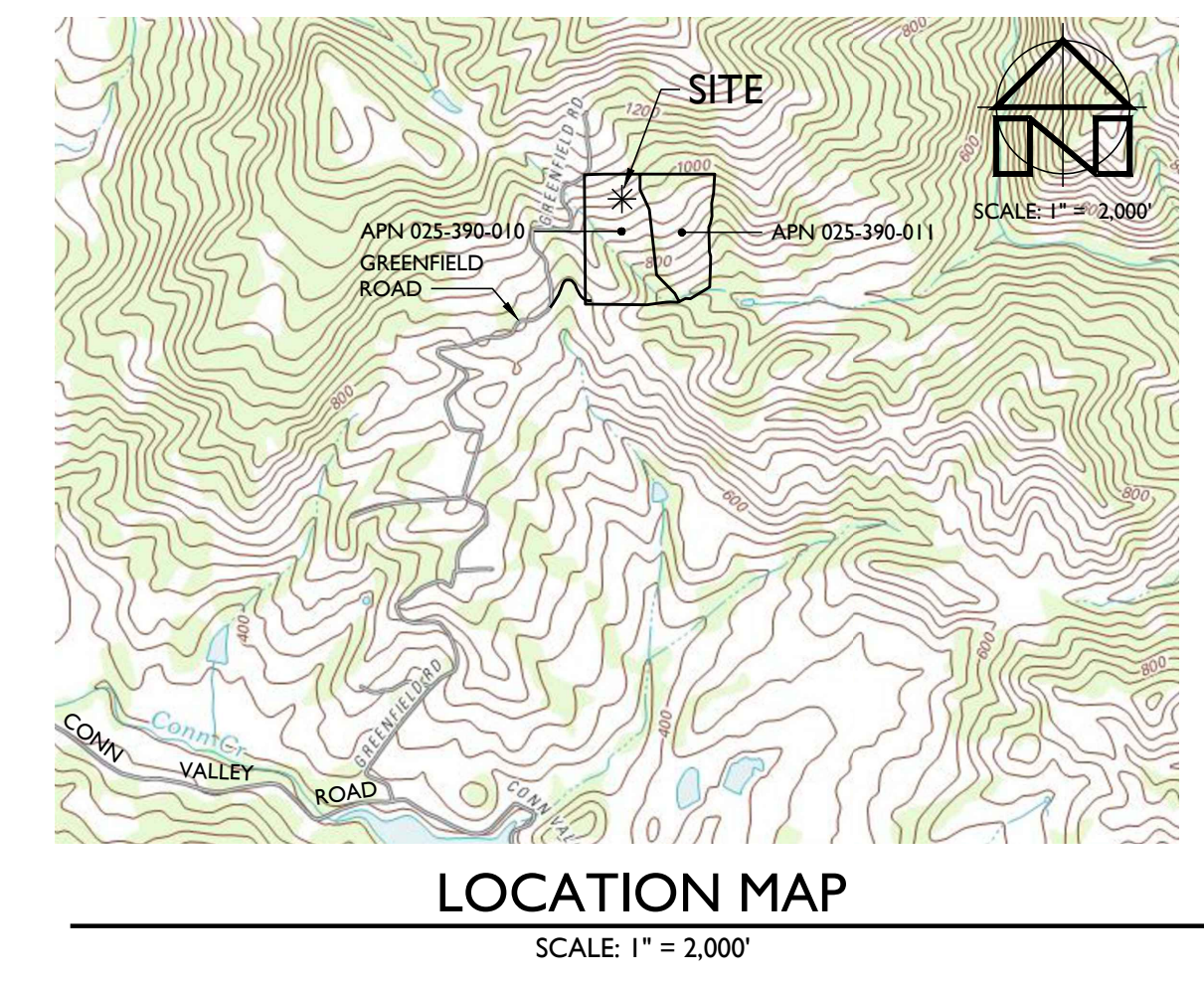
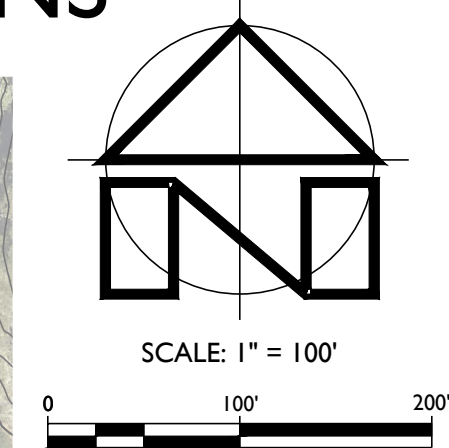
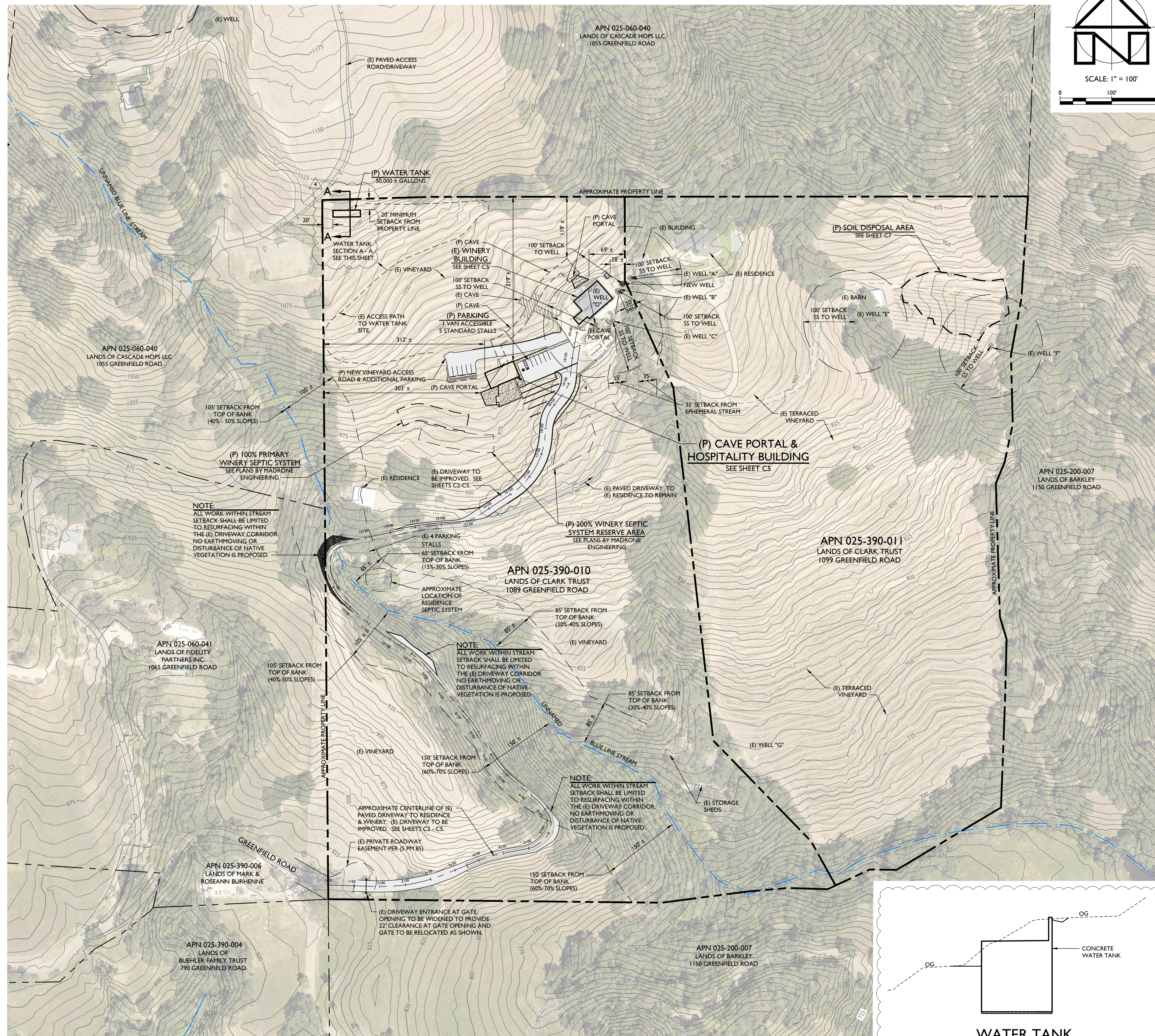

PROJECT INFORMATION:
PROPERTY OWNER & APPLICANT:
 CLARK & AMIZETTA TRUST
 1089 GREENFIELD ROAD
 SAINT HELENA, CA 94574
SITE ADDRESS:
 1089 GREENFIELD ROAD
 SAINT HELENA, CA 94574
ASSESSOR'S PARCEL NUMBER:
 025-390-010
PARCEL SIZE:
 21.5 ± ACRES
PROJECT SIZE:
 1.5 ± ACRES
ZONING:
 AGRICULTURAL WATERSHED (AW)
DOMESTIC WATER SOURCE:
 PRIVATE WELLS
FIRE PROTECTION WATER SOURCE:
 STORAGE TANK
WASTEWATER DISPOSAL:
 ONSITE TREATMENT AND DISPERSAL

SHEET INDEX:

C1	OVERALL SITE PLAN
C2	DRIVEWAY PLAN & PROFILES STA 1+00 TO STA 7+00
C3	DRIVEWAY PLAN & PROFILE STA 7+00 TO STA 12+00
C4	DRIVEWAY PLAN & PROFILE STA 12+00 TO STA 18+00
C5	DRIVEWAY PLAN & PROFILE STA 18+00 TO STA 20+00 ±
C6	DRIVEWAY SECTIONS STA 2+00 TO STA 20+00
C7	SOIL DISPOSAL AREA GRADING PLAN
C8	IMPERVIOUS SURFACE EXHIBIT
C9	STORMWATER CONTROL PLAN
C10	VEHICLE TRACKING EXHIBIT

PROJECT DESCRIPTION:
 THE PURPOSE OF THIS PROJECT IS TO MODIFY THE EXISTING WINERY FACILITY VIA A NEW USE PERMIT. THESE PLANS ILLUSTRATE THE CONCEPTUAL DESIGN OF A PORTION OF THE PROPOSED SITE IMPROVEMENTS ASSOCIATED WITH THE PROPOSED USE PERMIT.

FLOOD HAZARD NOTE:
 ACCORDING TO THE FEDERAL EMERGENCY MANAGEMENT AGENCY (FEMA) FLOOD INSURANCE RATE MAP (FIRM) MAP NUMBER 06055C0270E EFFECTIVE SEPTEMBER 26, 2008, THE PROJECT SITE IS NOT LOCATED IN A SPECIAL FLOOD HAZARD AREA.

NOTES:

- FADED BACKGROUND REPRESENTS EXISTING TOPOGRAPHIC FEATURES. TOPOGRAPHIC INFORMATION ON SHEET C1 WAS TAKEN FROM THE NAPA COUNTY GEOGRAPHIC INFORMATION SYSTEM DATABASE. TOPOGRAPHIC INFORMATION ON ALL OTHER SHEETS WAS TAKEN FROM THE "TOPOGRAPHIC MAP OF A PORTION OF THE LANDS OF AMIZETTA WINERY" PREPARED BY TERRA FIRMA SURVEYS, INC., DATED DECEMBER 10, 2018 AND UPDATED JANUARY 9, 2020. APPLIED CIVIL ENGINEERING INCORPORATED ASSUMES NO LIABILITY REGARDING THE ACCURACY OR COMPLETENESS OF THE TOPOGRAPHIC INFORMATION.
- AERIAL PHOTOGRAPHS WERE OBTAINED FROM THE NAPA COUNTY GEOGRAPHIC INFORMATION SYSTEM (GIS) DATABASE, TAKEN APRIL TO JUNE 2018 AND MAY NOT REPRESENT CURRENT CONDITIONS.
- CONTOUR INTERVAL:
 SHEET C1: FIVE (5) FEET, HIGHLIGHTED EVERY TWENTY FIVE (25) FEET.
 OTHER SHEETS: ONE (1) FOOT, HIGHLIGHTED EVERY FIVE (5) FEET.
- BENCHMARK: NAVD 88.
- THE PROPERTY LINES SHOWN ON THESE PLANS DO NOT REPRESENT A BOUNDARY SURVEY. THEY ARE APPROXIMATE AND ARE PROVIDED FOR INFORMATIONAL PURPOSES ONLY.

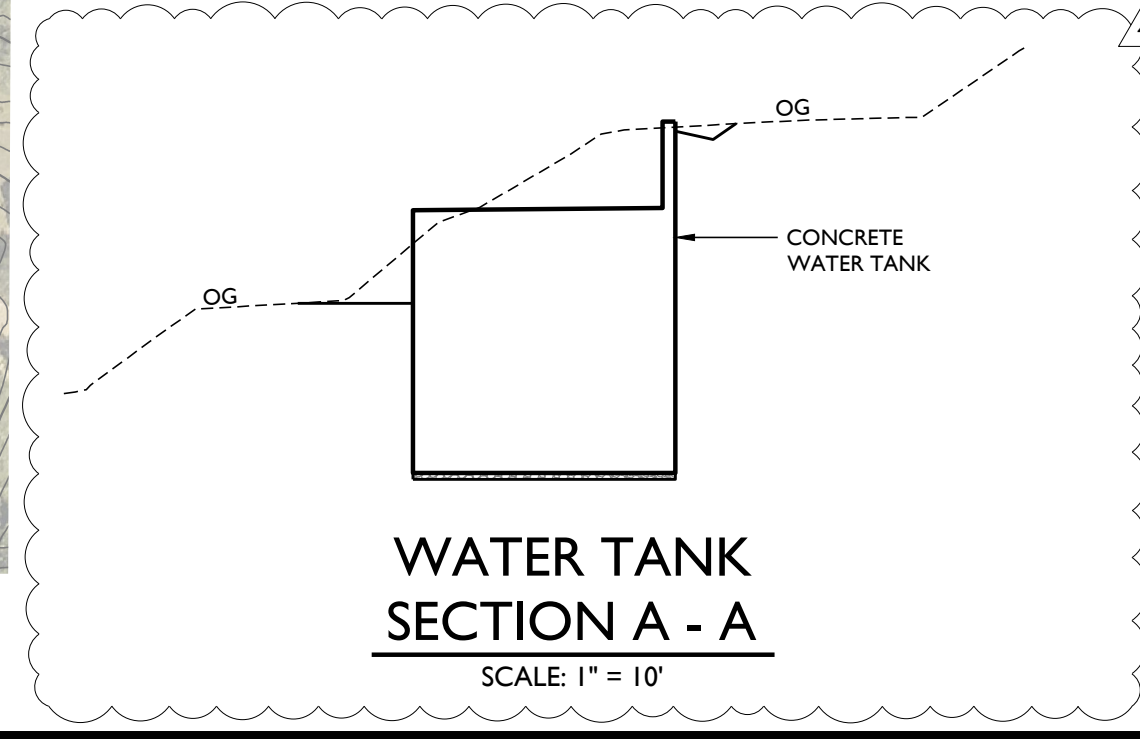

OVERALL SITE PLAN
SCALE: 1" = 100'

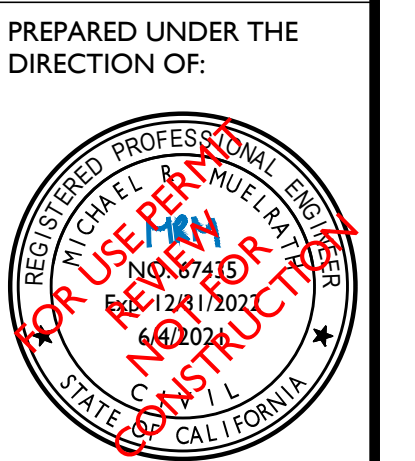

DRAWN BY: Power/CAD LLC
 CHECKED BY: MRM
 DATE: JUNE 4, 2021
 REVISIONS: BY: 3/18/2019 SMI PERMIT SUBMITTAL
 6/21/2019 BT RESPONSE TO COMMENTS
 4/17/2020 SMI RESPONSE TO COMMENTS
 1/25/2021 YMS CLIENT REVISION
 6/4/2021 YMS RESPONSE TO COMMENTS

JOB NUMBER: 18-155
 FILE: 18-155CONC-OSP.DWG
 ORIGINAL SIZE: 24" X 36"
 SHEET NUMBER: C1 OF 10

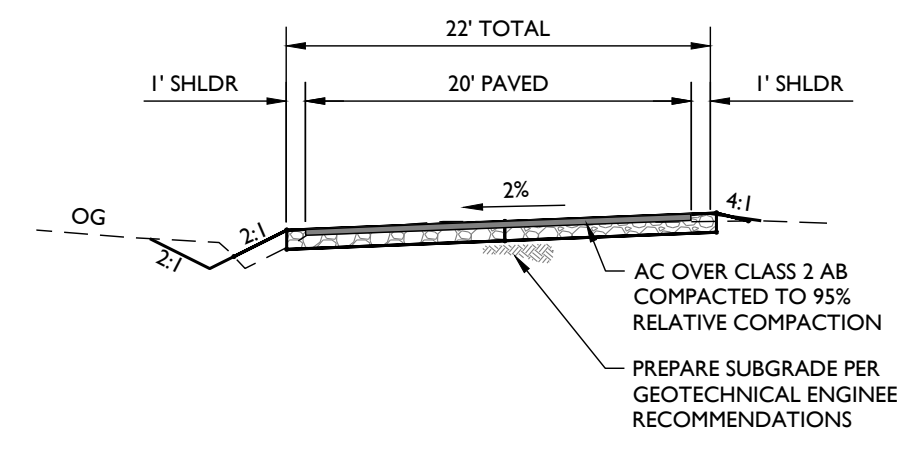

**SECTION A - A
@ STA 2+50**
SCALE: 1" = 10'

SEE SHEET C3
MATCHLINE STA 7+00

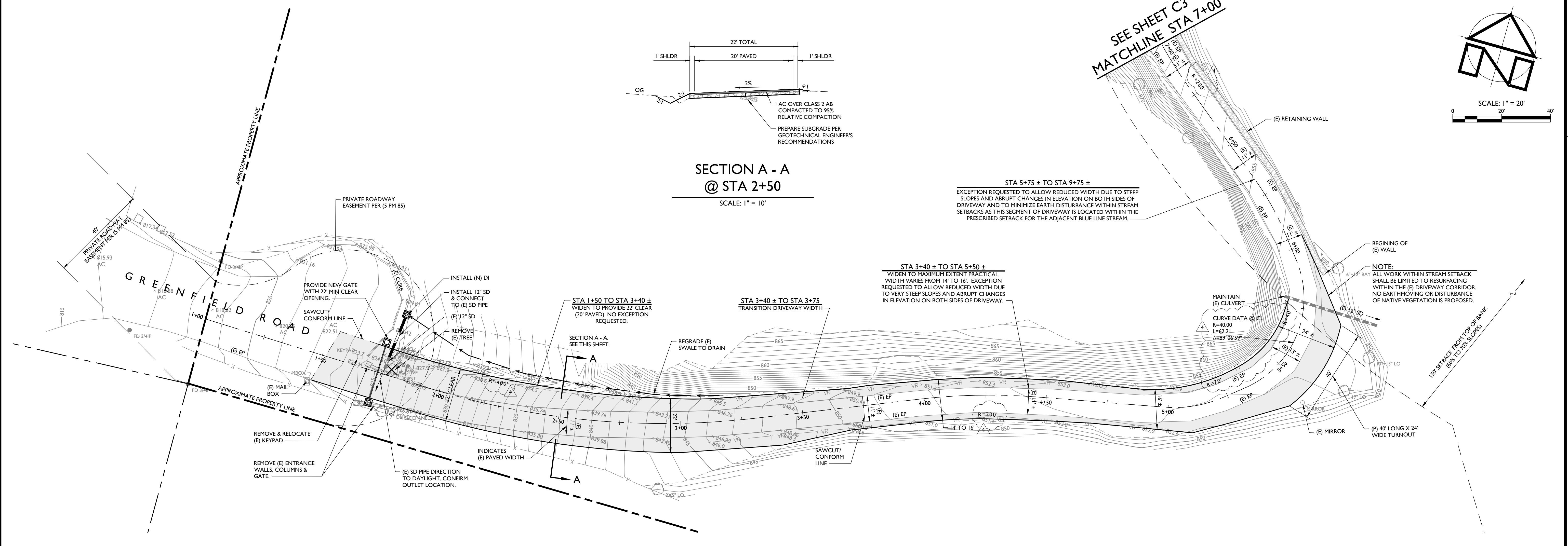
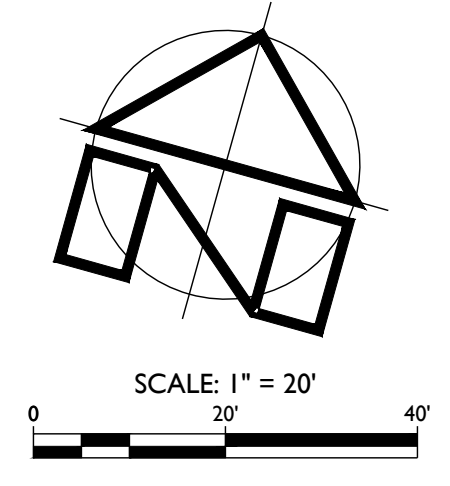

**DRIVEWAY PLAN
STA 1+00 TO STA 7+00**
SCALE: 1" = 20'

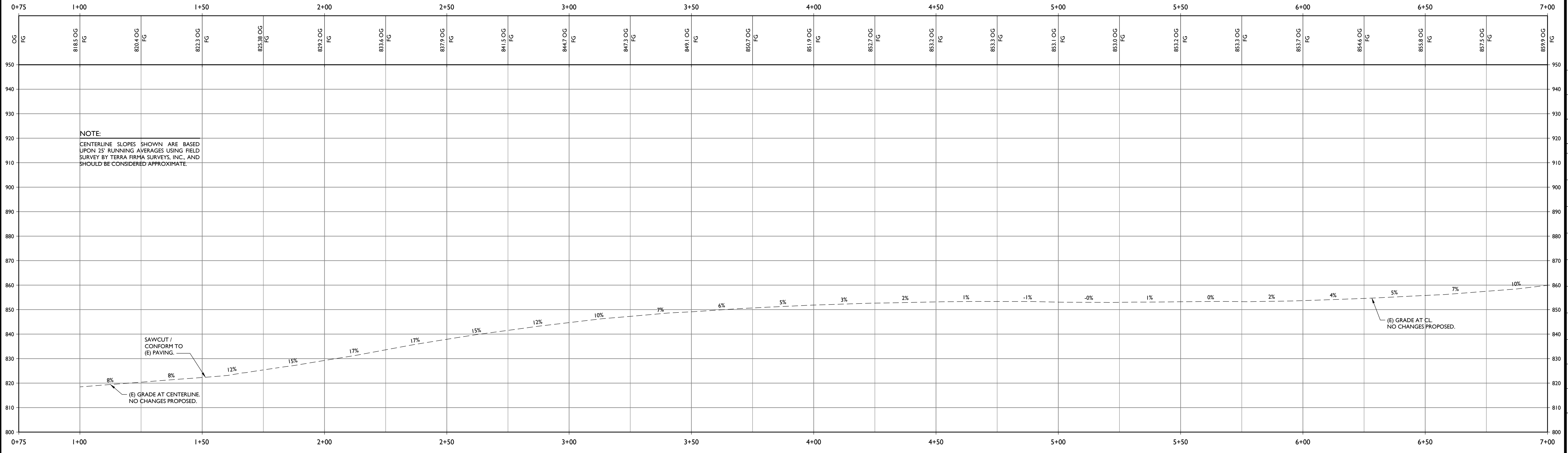

**DRIVEWAY PROFILE
STA 1+00 TO STA 7+00**
HORIZONTAL SCALE: 1" = 20'
VERTICAL SCALE: 1" = 20'

AMIZETTA WINERY

USE PERMIT CONCEPTUAL SITE IMPROVEMENT PLANS
DRIVEWAY PLAN & PROFILES STA 1+00 TO STA 7+00

PREPARED UNDER THE DIRECTION OF:

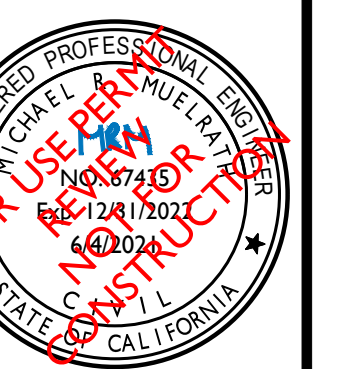

DRAWN BY:	PowerCAD LLC
CHECKED BY:	MRM
DATE:	JUNE 4, 2021
REVISIONS:	BY:
1	6/21/2019 BT
2	4/17/2020 SMI
3	1/25/2021 YMS
4	6/4/2021 YMS
JOB NUMBER:	18-155
FILE:	18-155CONC-P&P.DWG
ORIGINAL SIZE:	24" X 36"
SHEET NUMBER:	

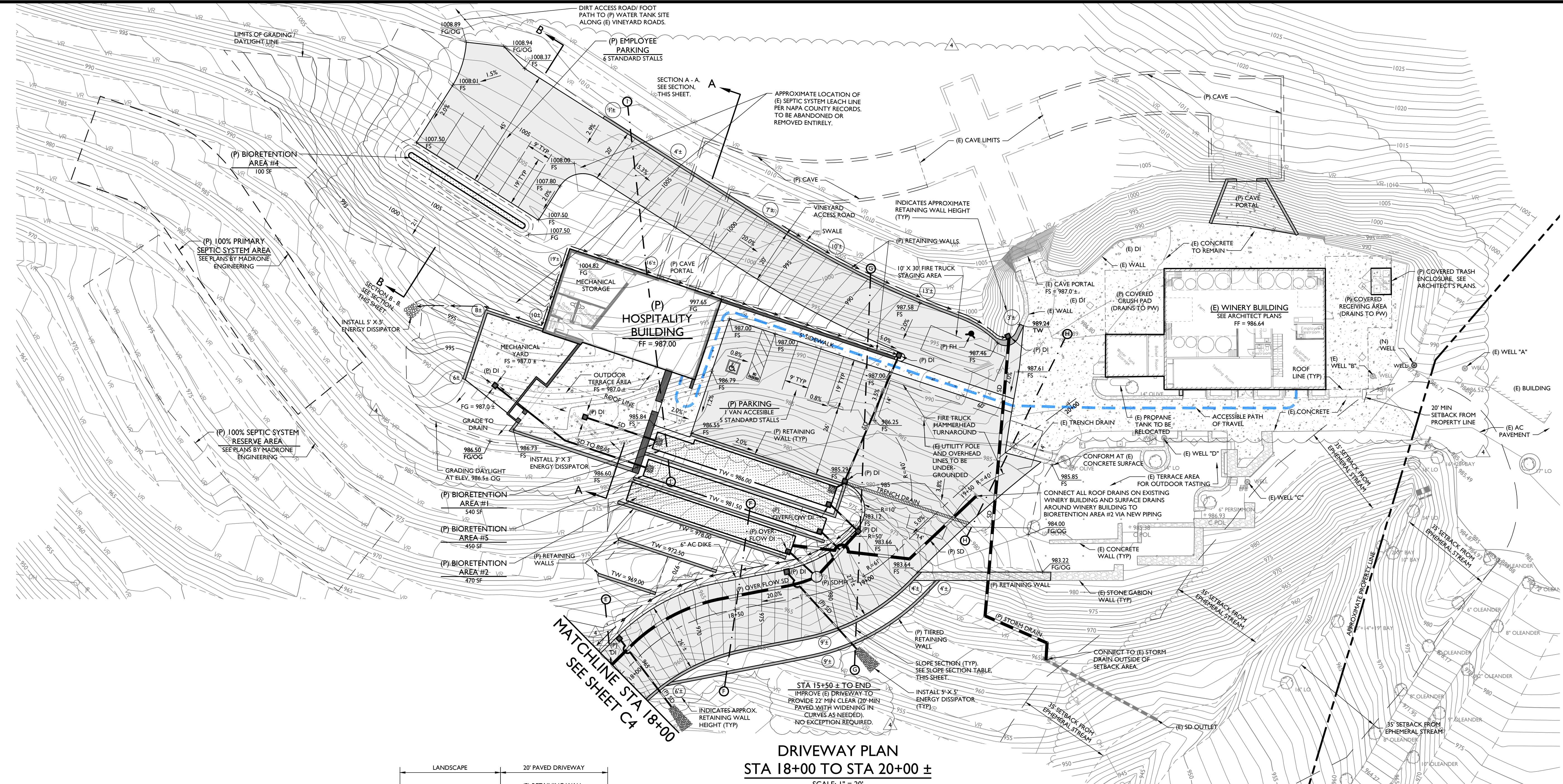
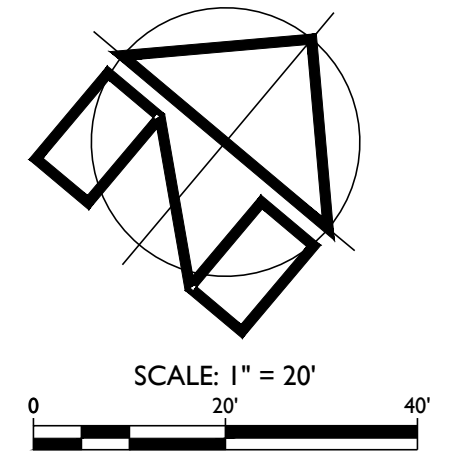

DRIVEWAY PLAN
STA 18+00 TO STA 20+00 ±
SCALE: 1" = 20'

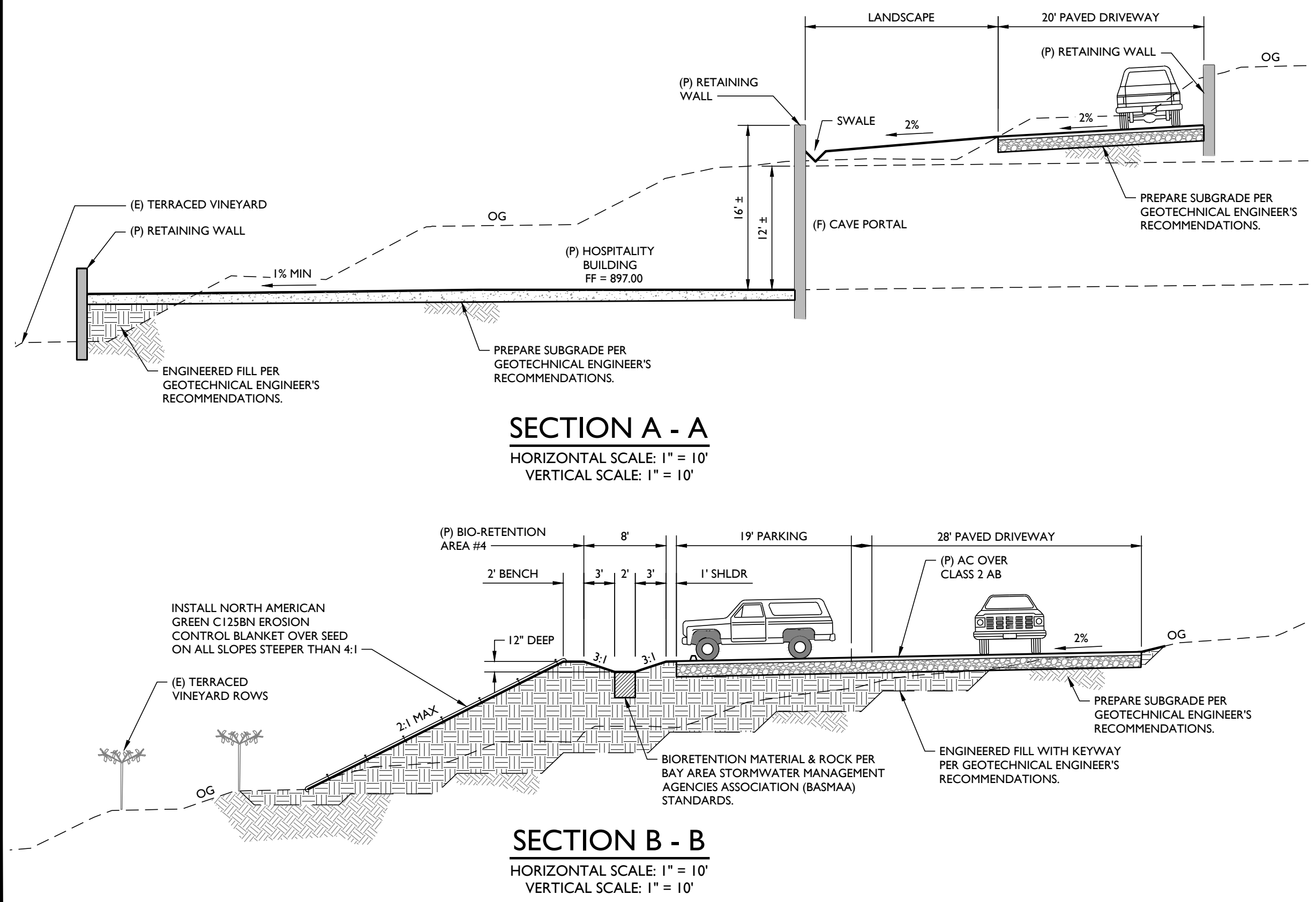

SECTION A - A
HORIZONTAL SCALE: 1" = 10'
VERTICAL SCALE: 1" = 10'

SECTION B - B
HORIZONTAL SCALE: 1" = 10'
VERTICAL SCALE: 1" = 10'

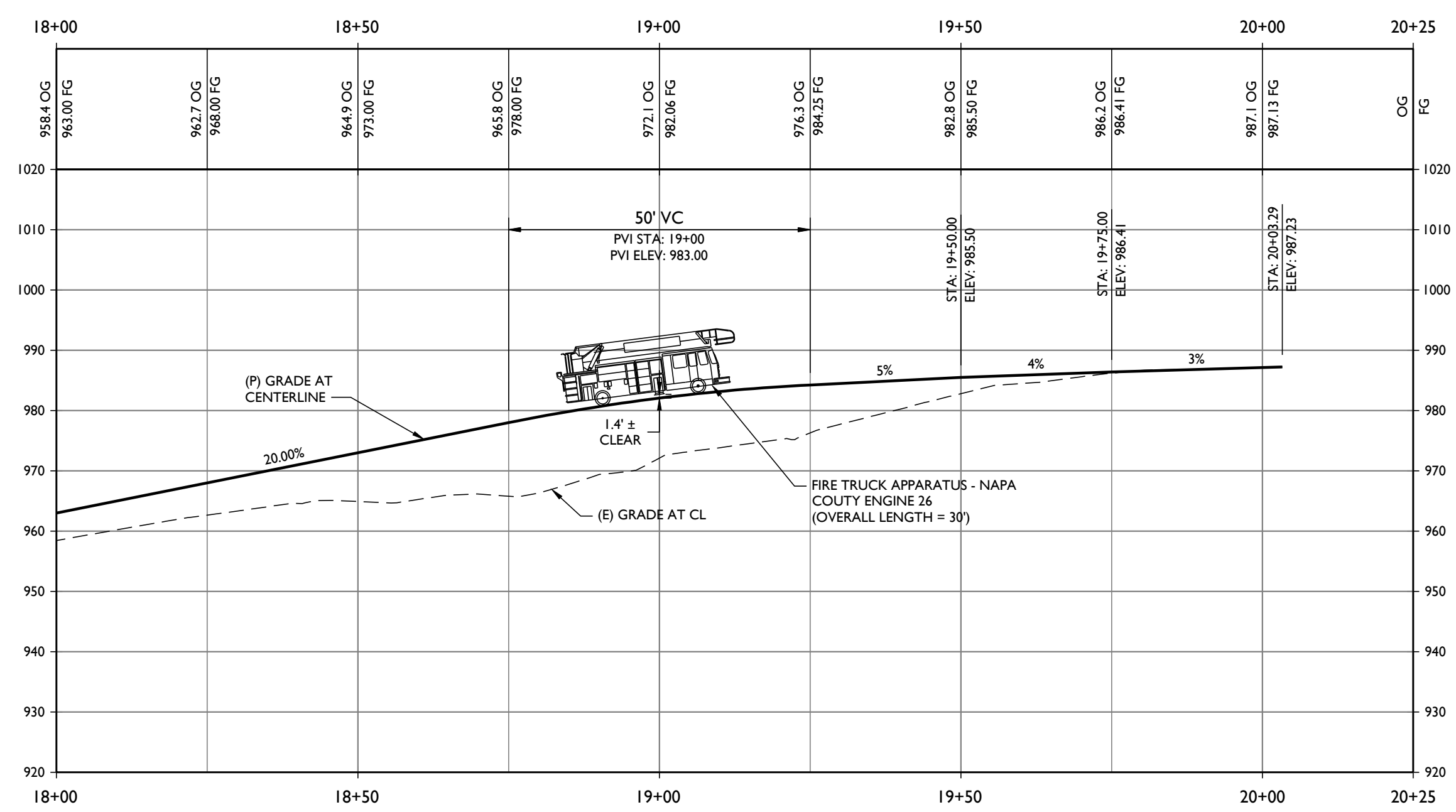

DRIVEWAY PROFILE
STA 18+00 TO STA 20+00 ±
HORIZONTAL SCALE: 1" = 20'
VERTICAL SCALE: 1" = 20'

SLOPE SECTIONS

A-A	46%
B-B	40%
C-C	28%
D-D	23%
E-E	27%
F-F	22%
G-G	29%
H-H	8%
I-I	22%
AVERAGE	27%

GRADING QUANTITIES*

DRIVEWAY & SITE GRADING	CUT	-3,000 ± CY
	FILL	+3,600 ± CY
CAVE EXCAVATION SPOILS	CUT	+600 ± CY
	FILL	-5,100 ± CY
TOTAL		-4,500 ± CY**
SPOILS DISPOSAL AREA	FILL	+2,700 ± CY
	NET**	-1,800 ± CY (CUT)

* THIS ESTIMATE IS PROVIDED AS A TOOL FOR THE REVIEWING AGENCIES TO EVALUATE THE ENVIRONMENTAL IMPACTS OF THE PROJECT. IT IS NOT INTENDED TO BE USED FOR CONSTRUCTION PURPOSES. CONTRACTOR IS TO PERFORM THEIR OWN EARTHWORK CALCULATIONS AND SHALL NOT USE THE ESTIMATES PRESENTED ABOVE. THIS ESTIMATE IS BASED ON IN PLACE VOLUMES AND DOES NOT INCLUDE PLUFF, SHRINKAGE, PAVING, AGGREGATES OR SELECT FILL VOLUMES.

** EXCESS SOIL CUT FROM THE PROJECT WILL BE PLACED IN THE SOIL DISPOSAL AREA. ANY REMAINING EXCESS WILL BE HAULED OFFSITE TO A PRE-APPROVED LOCATION.

AMIZETTA WINERY
 USE PERMIT CONCEPTUAL SITE IMPROVEMENT PLANS
 DRIVEWAY PLAN & PROFILE STA 18+00 TO STA 20+00 ±

PREPARED UNDER THE DIRECTION OF:



DRAWN BY: Power/CAD LLC

CHECKED BY: MRM

DATE: JUNE 4, 2021

REVISIONS: BY: 3/18/2019 SMI PERMIT SUBMITTAL

6/21/2019 BT RESPONSE TO COMMENTS

4/17/2020 SMI RESPONSE TO COMMENTS

1/25/2021 YMS CLIENT REVISION

6/4/2021 YMS RESPONSE TO COMMENTS

JOB NUMBER: 18-155

FILE: 18-155CONC-P&P.DWG

ORIGINAL SIZE: 24" X 36"

SHEET NUMBER:

C5

OF

10

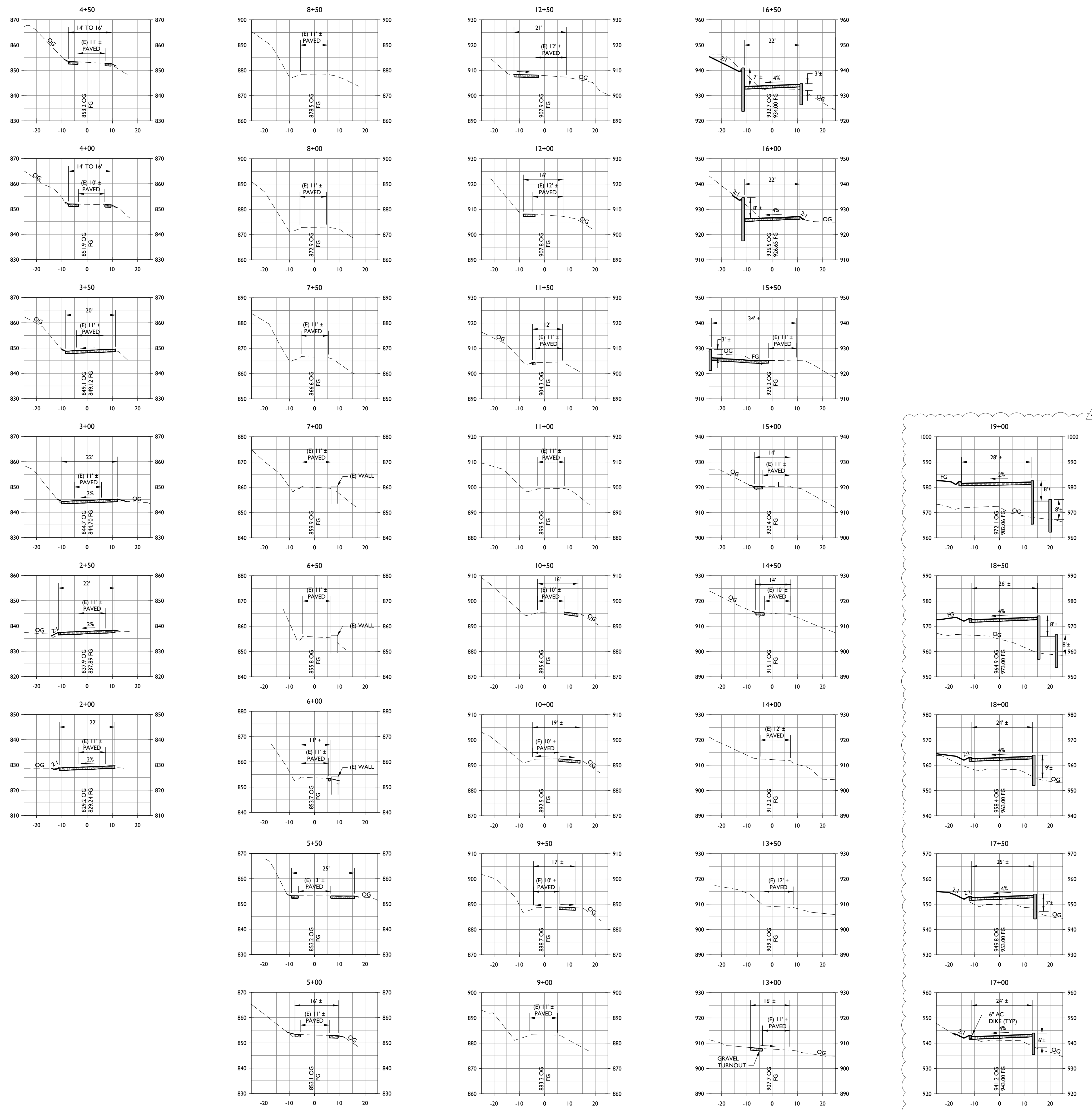

DRIVEWAY SECTIONS STA 2+00 TO STA 20+00

SCALE: 1" = 20'

AMIZETTA WINERY
USE PERMIT CONCEPTUAL SITE IMPROVEMENT PLANS
DRIVEWAY SECTIONS STA 2+00 TO STA 20+00

PREPARED UNDER THE DIRECTION OF:



DRAWN BY: PowerCAD LLC	
CHECKED BY: MRM	
DATE: JUNE 4, 2021	
REVISIONS:	BY:
1	3/18/2019 SMI PERMIT SUBMITTAL
2	6/21/2019 BT RESPONSE TO COMMENTS
3	4/17/2020 SMI RESPONSE TO COMMENTS
4	1/25/2021 YMS CLIENT REVISION
5	6/4/2021 YMS RESPONSE TO COMMENTS
JOB NUMBER: 18-155	
FILE: 18-155CONC-SECT.DWG	
ORIGINAL SIZE: 24" X 36"	
SHEET NUMBER:	

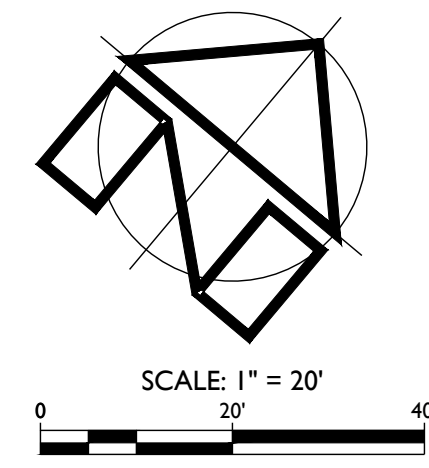

APN 025-390-011
LANDS OF CLARK TRUST
1099 GREENFIELD ROAD

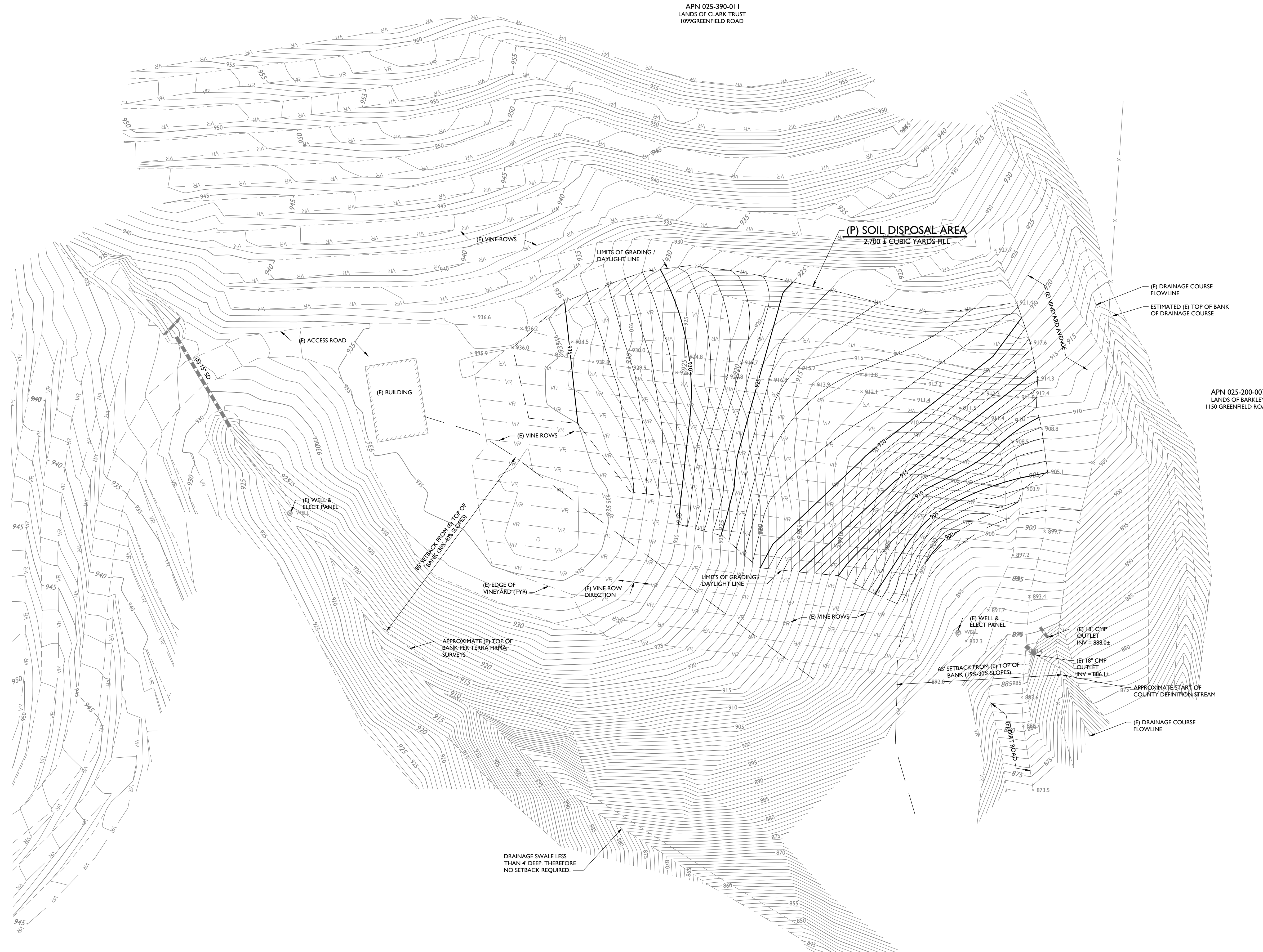

**SOIL DISPOSAL AREA
GRADING PLAN**

SCALE: 1" = 20'

AMIZETTA WINERY

USE PERMIT CONCEPTUAL SITE IMPROVEMENT PLANS
SOIL DISPOSAL AREA GRADING PLAN

PREPARED UNDER THE
DIRECTION OF:



DRAWN BY:
PowerCAD LLC

CHECKED BY:
MRM

DATE:
JUNE 4, 2021

REVISIONS: BY:
3/18/2019 SMI
PERMIT SUBMITTAL

1. 6/21/2019 BT
RESPONSE TO
COMMENTS

2. 4/17/2020 SMI
RESPONSE TO
COMMENTS

3. 1/25/2021 YMS
CLIENT REVISION

4. 6/4/2021 YMS
RESPONSE TO
COMMENTS

JOB NUMBER:
18-155

FILE:
18-155CONC-GRAD.DWG

ORIGINAL SIZE:
24" X 36"

SHEET NUMBER:

C7
OF
10

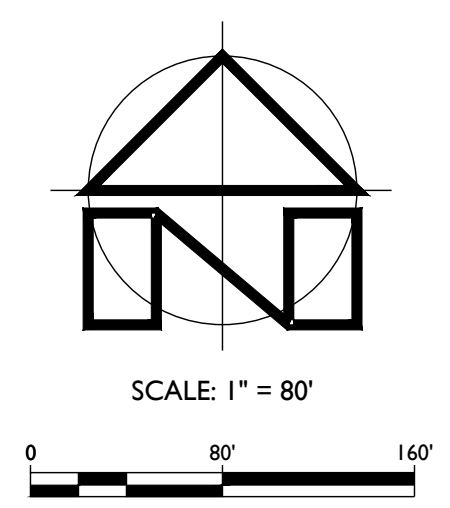
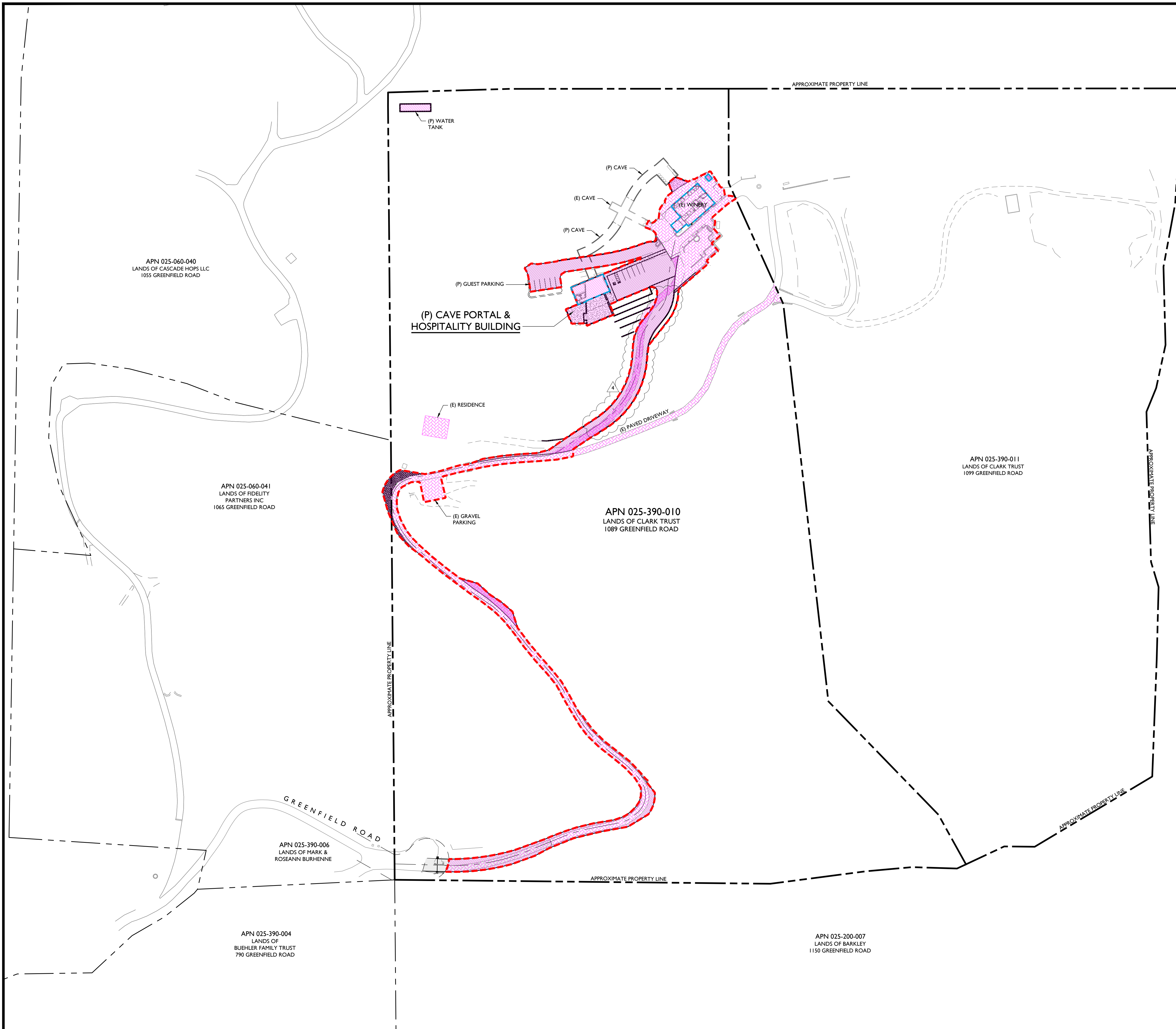

AMIZETTA WINERY
 USE PERMIT CONCEPTUAL SITE IMPROVEMENT PLANS
 IMPERVIOUS SURFACE EXHIBIT

PREPARED UNDER THE DIRECTION OF:

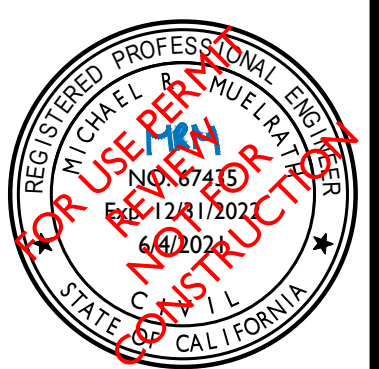

DRAWN BY:
PowerCAD LLC

CHECKED BY:
MRM

DATE:
JUNE 4, 2021

REVISIONS: BY:
3/18/2019 SMI PERMIT SUBMITTAL

1. 6/21/2019 BT RESPONSE TO COMMENTS

2. 4/17/2020 SMI RESPONSE TO COMMENTS

3. 1/25/2021 YMS CLIENT REVISION

4. 6/4/2021 YMS RESPONSE TO COMMENTS

JOB NUMBER:
18-155

FILE:
18-155CONC-ISE.DWG

ORIGINAL SIZE:
24" X 36"

SHEET NUMBER:

C8
OF
10

IMPERVIOUS SURFACE SUMMARY

TOTAL AREA OF IMPERVIOUS SURFACE	PRE-PROJECT AREA (SF)	NEW AREA (SF)	RECONSTRUCTED AREA (SF)		TOTAL NEW AND RECONSTRUCTED AREA (SF)
	A ¹	B ²	A ¹	B ²	
43,610	30,365	5,330	385		35,695

¹RECONSTRUCTED AREAS (A) ARE EXISTING IMPERVIOUS SURFACES THAT ARE BEING REPLACED WITH NEW IMPERVIOUS SURFACES.

²RECONSTRUCTED AREAS (B) ARE EXISTING IMPERVIOUS SURFACES THAT ARE BEING COMPLETELY REMOVED AND ARE NOT BEING REPLACED WITH NEW IMPERVIOUS SURFACES.



IMPERVIOUS SURFACE EXHIBIT
SCALE: 1" = 80'

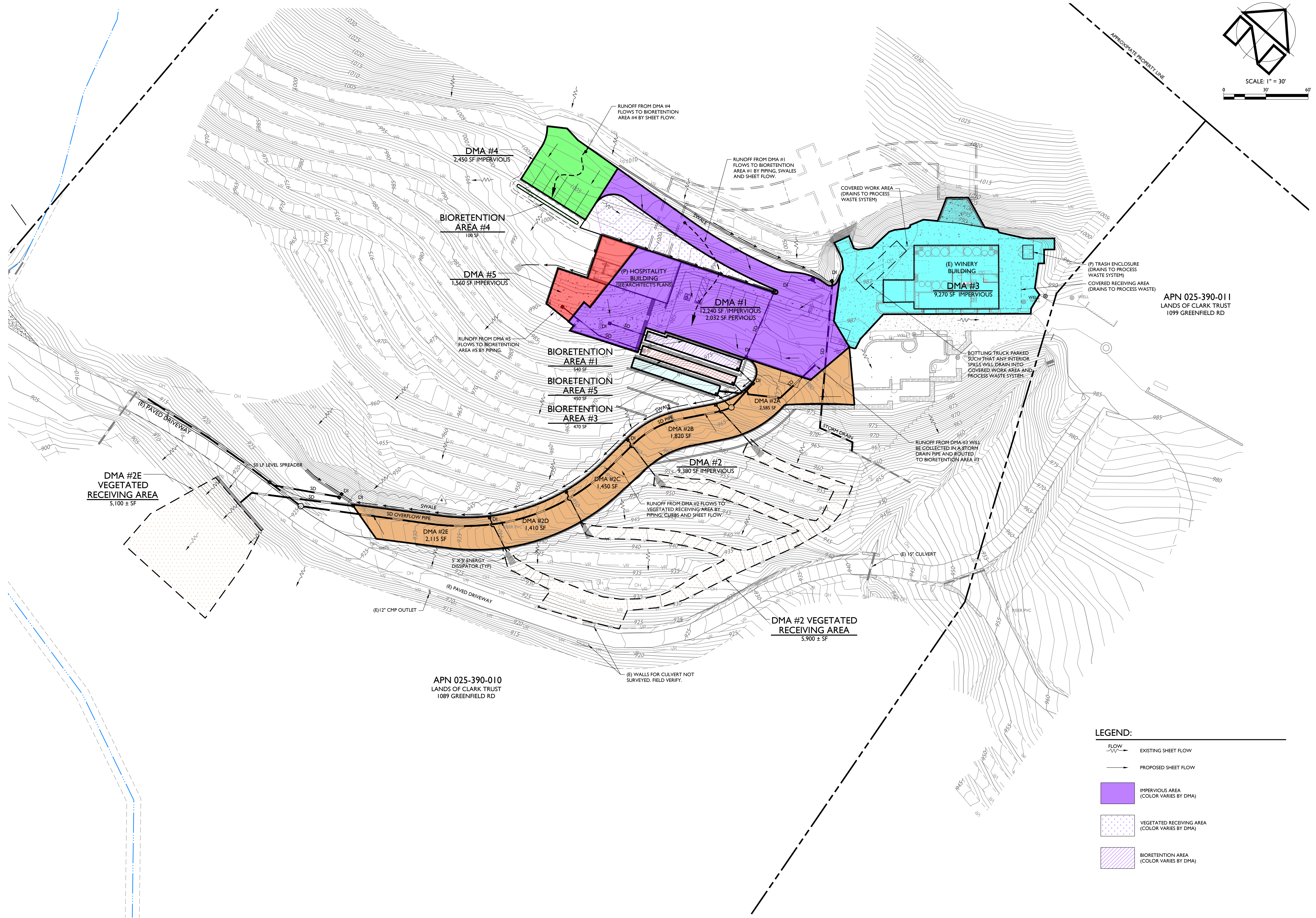
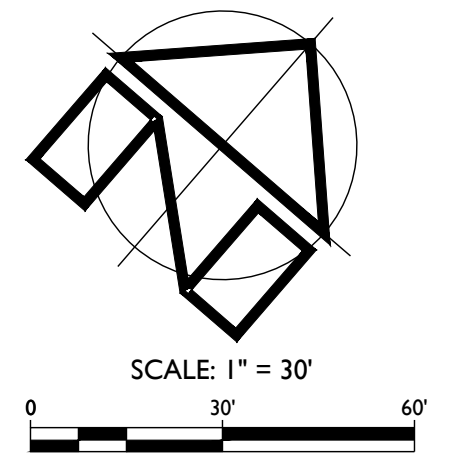

APN 025-390-011
LANDS OF CLARK TRUST
1099 GREENFIELD RD

APN 025-390-010
LANDS OF CLARK TRUST
1089 GREENFIELD RD

AMIZETTA WINERY
USE PERMIT CONCEPTUAL SITE IMPROVEMENT PLANS
STORMWATER CONTROL PLAN

PREPARED UNDER THE DIRECTION OF:

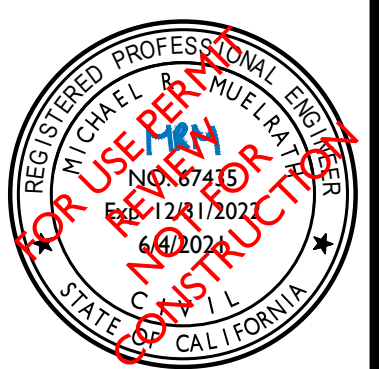

DRAWN BY:
PowerCAD LLC

CHECKED BY:
MRM

DATE:
JUNE 4, 2021

REVISIONS: BY:
3/18/2019 SMI
PERMIT SUBMITTAL

1 6/21/2019 BT
RESPONSE TO COMMENTS

2 4/17/2020 SMI
RESPONSE TO COMMENTS

3 1/25/2021 YMS
CLIENT REVISION

4 6/4/2021 YMS
RESPONSE TO COMMENTS

JOB NUMBER:
18-155

FILE:
18-155CONC-SCP.DWG

ORIGINAL SIZE:
24" X 36"

SHEET NUMBER:

C9
OF

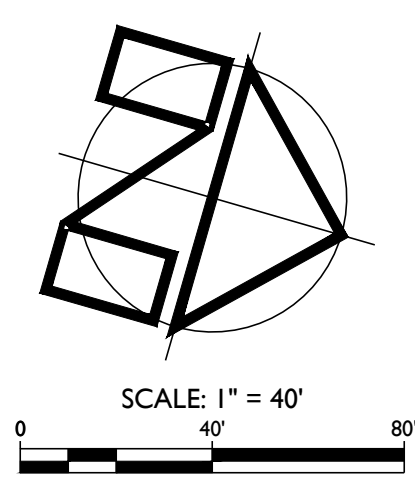
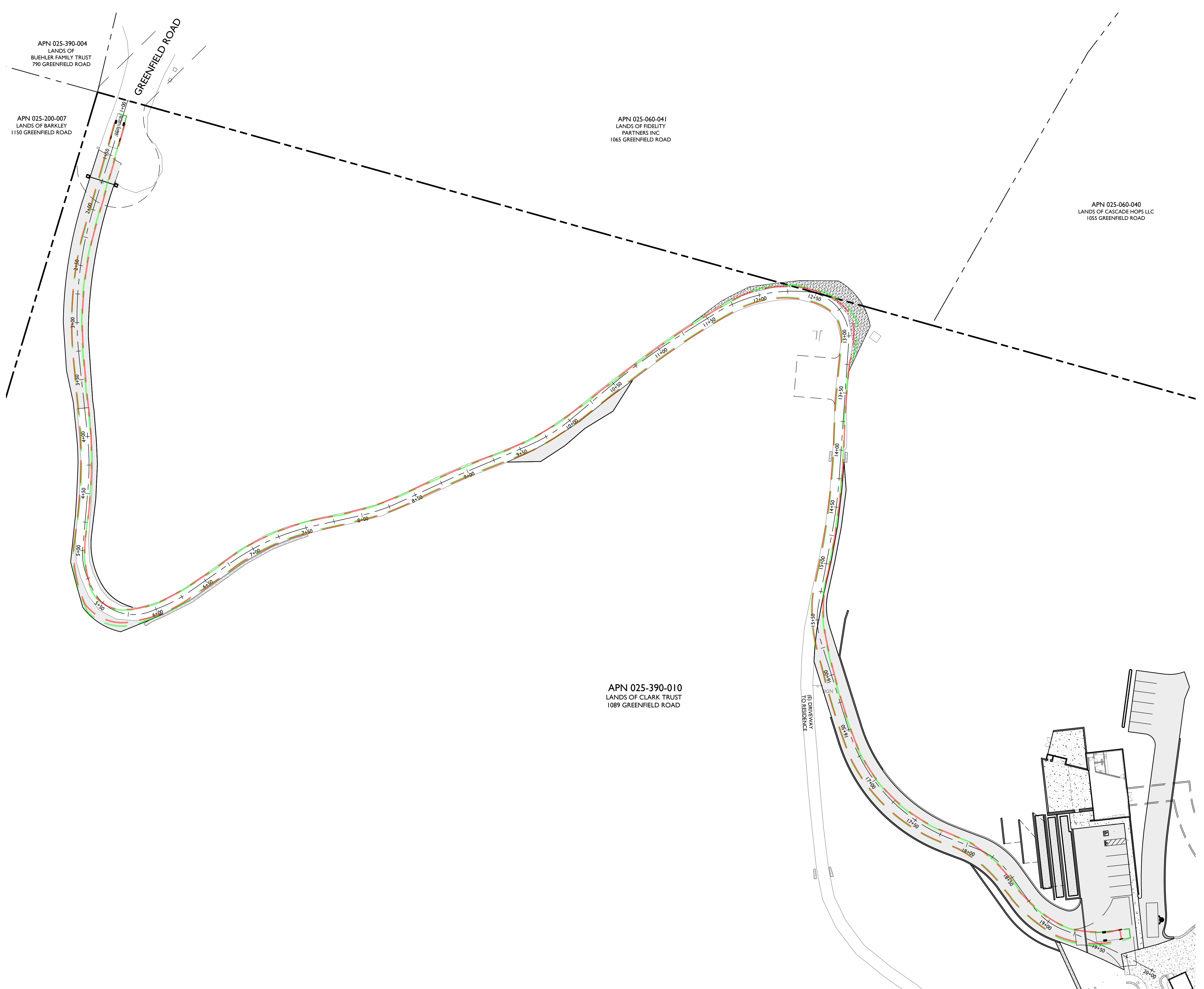

APN 025-390-004
LANDS OF
BUEHLER FAMILY TRUST
790 GREENFIELD ROAD

APN 025-200-007
LANDS OF BARKLEY
1150 GREENFIELD ROAD

APN 025-060-041
LANDS OF FIDELITY
PARTNERS INC
1065 GREENFIELD ROAD

APN 025-060-040
LANDS OF CASCADE HOPS LLC
1055 GREENFIELD ROAD

APN 025-390-010
LANDS OF CLARK TRUST
1089 GREENFIELD ROAD

- LEGEND:**
- APPROXIMATE PROPERTY LINE (SUBJECT PROPERTY)
 - APPROXIMATE PROPERTY LINE (ADJACENT PROPERTY)
 - PROPOSED EDGE OF PAVEMENT
 - FIRE TRUCK TURN PATH - WHEEL
 - FIRE TRUCK TURN PATH - BUMPER

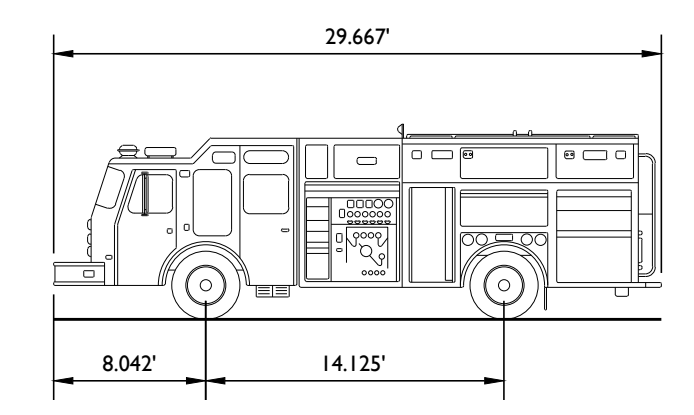

NAPA COUNTY FIRE TRUCK E26

OVERALL LENGTH	29.667 FT
OVERALL WIDTH	8.000 FT
OVERALL BODY HEIGHT	10.609 FT
MIN BODY GROUND CLEARANCE	1.040 FT
TRACK WIDTH	9.015 FT
LOCK-TO-LOCK TIME	4.00 S
CURB TO CURB TURNING RADIUS	26.417 FT

FIRE TRUCK PROFILE
NOT TO SCALE

VEHICLE TRACKING EXHIBIT
SCALE: 1" = 40'

AMIZETTA WINERY
USE PERMIT CONCEPTUAL SITE IMPROVEMENT PLANS
VEHICLE TRACKING EXHIBIT

PREPARED UNDER THE DIRECTION OF:



DRAWN BY:
PowerCAD LLC

CHECKED BY:
MRM

DATE:
JUNE 4, 2021

REVISIONS: BY:

- 3/18/2019 SMI PERMIT SUBMITTAL
- 6/21/2019 BT RESPONSE TO COMMENTS
- 4/17/2020 SMI RESPONSE TO COMMENTS
- 1/25/2021 YMS CLIENT REVISION
- 6/4/2021 YMS RESPONSE TO COMMENTS

JOB NUMBER:
18-155

FILE:
18-155CONC-FIRE.DWG

ORIGINAL SIZE:
24" X 36"

SHEET NUMBER:

C10
OF
10



A Tradition of Stewardship
A Commitment to Service

Planning, Building & Environmental Services

1195 Third Street, Suite 210
Napa, CA 94559
www.countyofnapa.org

David Morrison
Director

MEMORANDUM

To: Sean Trippi, Project Planner	From: Kim Withrow, Environmental Health Supervisor
----------------------------------	--

Date: June 25, 2021	Re: Amizetta Family Estate Wines APN: 025-090-010 Project #: P19-00132
---------------------	--

This Division has reviewed a revised application requesting approval for a use permit for an existing small winery, the application requests an increase in employees, to add tasting visitors, and an increase in production among other items necessary to support the request as depicted and described in application materials. This Division has no objection to approval of the application with the following conditions of approval:

Upon use permit approval and prior to building permit issuance:

1. Plans for the proposed wastewater system improvements as described in Wastewater Feasibility Report dated January 2021 shall be designed by a licensed Civil Engineer or Registered Environmental Health Specialist and be accompanied by complete design criteria based upon local conditions and submitted for review and approval. No building clearance (or issuance of a building permit) for any structure that generates wastewater to be disposed of by this system will be approved until such plans are approved by this Division.
2. A permit to install the proposed wastewater system improvements must be secured from this Division prior to approval of a building clearance (or issuance of a building permit) for any structure that generates wastewater to be disposed of by this system. An annual operating permit or enrollment in the California Water Resources Control Board’s Winery General Order will be required.
3. Complete plans and specifications for the food preparation, service area(s), storage area(s) and the employee restrooms must be submitted for review and approval by this Division prior to issuance of any building permits for said areas. An annual food permit will be required. The pizza oven and grill must be located in reasonable proximity to the commercial kitchen. The plans shall clearly demonstrate the path of travel between the outdoor cooking appliances and the kitchen.

4. The water supply and related components must comply with the California Safe Drinking Water Act and Related Laws. This will require plan review and approval prior to approval of building permits. The technical report must be completed by a licensed engineer with experience in designing water systems. The preliminary technical report must be submitted to the Regional Water Quality Control Board staff a minimum of six (6) months prior to beginning any water-related improvement in accordance with the California Health and Safety Code, Section 116527. Prior to occupancy, the owner must apply for and obtain an annual operating permit for the water system from this Division. The applicant must comply with all required monitoring and reporting.

During construction and prior to final occupancy:

5. During the construction, demolition, or renovation period of the project the applicant must use the franchised garbage hauler for the service area in which they are located for all wastes generated during project development, unless applicant transports their own waste. If the applicant transports their own waste, they must use the appropriate landfill or solid waste transfer station for the service area in which the project is located.
6. Annual operating permits shall be obtained for the wastewater system(s), water system and food facility after construction but prior to beginning operations.

Upon final occupancy and thereafter:

7. Some proposed food service will be catered; therefore, all catered food must be prepared and served by a Napa County permitted caterer. If the caterer selected does not possess a valid Napa County Permit to operate, refer the business to this Division for assistance in obtaining the required permit prior to providing any food service.
8. The applicant shall maintain regular monitoring of the wastewater system(s) as required by this Division. An annual operating permit is required to ensure compliance with Napa County Code. It is recommended the applicant begin to keep a log of process water generated for future enrollment under the State of California Water Quality Control Board Winery General Order.
9. Within 30 (thirty) days of initiation of the use or change of tenants, an updated Hazardous Materials Business shall be submitted to <http://cers.calepa.ca.gov/> and approved by this Division.
10. The use of the absorption field/drain field area shall be restricted to activities which will not contribute to compaction of the soil with consequent reduction in soil aeration. Activities which must be avoided in the area of the septic system include equipment storage, traffic, parking, pavement, livestock, etc.
11. All solid waste shall be stored and disposed of in a manner to prevent nuisances or health threats from insects, vectors and odors.



A Tradition of Stewardship
A Commitment to Service

Planning, Building, & Environmental Services

1195 Third Street, Suite 210
Napa, CA 94559
www.co.napa.ca.us

Main: (707) 253-4417
Fax: (707) 253-4336

David Morrison
Director

To: Sean Trippi, Project Planner	From: Stacie Gutierrez, Plans and Permit Supervisor
Date: November 26, 2019	Re: Amizetta Winery P19-00132

Building Inspection Division; Planning Use Permit Review Comments

APN: 025-390-010

Project: Amizetta Winery

Comments: The Building Division is not reviewing this project for compliance with the California Building Standards at this time; the Building Division is reviewing the proposed Planning entitlements only, the Building Division has no issues or concerns with the approval of the Use Permit P19-00132; it is a Planning entitlement and does not in itself authorize any construction activities. Separate building permits shall be required.

The plans provided for the Use Permit application P19-00132 do not provide enough information in sufficient detail to determine all code building code requirements. A complete and thorough plan review will be performed at the time of application is made for the required building, plumbing, mechanical, electrical, and any other construction permits required by other Napa County Agencies. The following comments are provided to make the applicant aware of what codes the applicant will be required to comply with, as well as issues that may need to be addressed prior/during the building permit application and review process.

1. Building permits will be required to be pulled for structures and improvements proposed in the Use Permit. All permits are valid 365 days from issuance of the permit. Please see the Building Departments website for more information on submittal requirements.
2. In accordance with the California Building Code, Chapter 1, Division 1, Section 1.1.9, which states, "only those standards approved by the California Building Standards Commission that are effective at the time of application for a building permit is submitted shall apply to the plans and specifications for and to the construction under that permit.. The codes adopted at this time are the 2016 California Building Standards

Codes, Title 24, part 2, Building volumes 1 &2, part 3 Electrical, part 4 Mechanical, part 5 Plumbing, part 6 Energy, part 9 Fire and part 11 Green Buildings. Please be aware there is a code change coming in 2020, so all plans submitted after December 31, 2019 will need to comply with 2019 California Building Standard Codes.

3. Consult with your design professional to ensure at the time of Building Permit submittal that you have provided that proper separation from any mixed occupancies. In particular proper separation from the tasting room and barrel storage. Have your design professional provide an exit plan at the time of permit application.
4. Consult with your design professional to design an Accessibility Plan. The site and associated buildings are required to be accessible to persons with disabilities. This includes but not limited to a van accessible parking stall, accessible path of travel from the parking stall to all buildings, restrooms, and areas on the site that are available to employees and the public. This plan will be reviewed during the plan review for your building permit.
5. Consult with your design professional to have a proper egress and exiting plan showing all occupancy types, occupant loads, and travel distances. Show Path of travel. An identifiable accessible route within an existing site, building or facility by means of which a particular area may be approached, entered and exited, and which connects a particular area with an exterior approach (including sidewalks, streets and parking areas), an entrance to the facility, and other parts of the facility. When alterations, structural repairs or additions are made to existing buildings or facilities, the term "path of travel" also includes the toilet and bathing facilities, telephones, drinking fountains and signs serving the area of work. This plan will be reviewed during the plan review for your building permit.
6. During plan review, occupant loads will determine occupancy types, exiting requirements, and restroom facilities. All occupancy classifications and occupancy load calculations shall be noted on the plans. Consult with your design professional to make sure they accounted for that during the design phase.
7. Any existing structures and/or buildings on the property that will be demolished require a separate demolition permit issued by The Napa County Building Division prior to demolition. The applicant will be required to provide a J number form Bay Area Air Quality Management District at the time of application for the permit.

Issues with the compliance with the California Building Code, Title 24, will be addressed during the building permit application, review and approval process. If there are any questions, please have the applicant give me a call at (707) 299-1337.

All plans and documents for commercial projects are required by California Law to be prepared and coordinated under the direction of a California Licensed Design Professional, such as an Architect and/or Engineer in accordance with the California Business and Professions Code Chapter 3, and the California Building Code, Chapter 1.

Stacie Gutierrez
Plans and Permit Supervisor
County of Napa Building Department
1195 Third Street, Suite 210
Napa, CA 94558
Stacie.gutierrez@countyofnapa.org



A Tradition of Stewardship
A Commitment to Service

Department of Public Works

1195 Third Street, Suite 101
Napa, CA 94559-3092
www.countyofnapa.org/publicworks

Main: (707) 253-4351
Fax: (707) 253-4627

Steven Lederer
Director

MEMORANDUM

To: PBES Staff	From: Ahsan Kazmi, P.E. Senior Traffic Engineer
Date: February 25, 2021	Re: Amizetta Winery (P19-00132) Conditions of Approval

This memorandum on the Conditions of Approval is prepared at the request of Planning, Building, and Environmental Services (PBES) staff regarding the Minor Use Permit Modification Application # P19-00132, for the proposed Amizetta Winery, located at 1099 Greenfield Road in the County of Napa.

In preparation of this memorandum, we have reviewed the County of Napa Use Permit Application and Project Statement dated January 23, 2021.

After careful evaluation of the project application and review of the trip generation worksheets, we believe that the application has sufficient information to develop conditions for the project. The project is not expected to exceed 40 daily trips, therefore a traffic impact study report is not required.

The Department of Public Works established the following conditions of approval related to the Use Permit Application Number 19-00132. However, the approval is contingent to the Fire Department and PBES Engineering approvals related to the Scope of Work Proposal for Wildfire Issues on Greenfield Road, prepared by Mr. David Shew, Wildfire Defense Works, dated; January 20, 2021:

Marketing

1. The project applicant/permittee shall not exceed the maximum number of visitors of 30 per day, 210 per week.
2. The project applicant will not exceed 11 marketing events per year.

On Street Parking

3. Parking within the public right-of-way will be prohibited during visitation and marketing events.

Landscape Maintenance

4. Landscaping at the project driveway shall be maintained to not interfere with sight lines requires for safe stopping distance on the public-right-of-way. No items that are wide than 18 inches can be taller than 30 inches other than street trees and traffic control devices. Street trees should be deciduous and have branches lower than 4 feet in height up kept once the tree is established.

Encroachment Permit

5. An encroachment permit will be required for any improvements in the County's Right-of-Way. For the application submittal process contact the Roads Division at 707-944-0196. The improvements shall be constructed in compliance with the Napa County Road & Street Standards. The Registered Civil Engineer, upon completion of the improvements, must certify to the Department of Public Works that the improvements are made in accordance with all conditions of approval, including any related land use permit conditions and the approved improvement plans. Completion of improvements and certification shall be completed prior to occupancy or establishment of use. Please contact the Roads office at (707) 944-0196 to initiate the encroachment permit process. Any improvements located on Caltrans Right-of-Way will require a separate coordination and permitting process.

Please contact Ahsan Kazmi, P.E. Senior Traffic Engineer at Ahsan.Kazmi@countyofnapa.org or call (707) 259-8370 if you have any questions.



A Tradition of Stewardship
A Commitment to Service

Napa County Fire Department
Fire Marshal's Office
Hall of Justice, 2nd Floor
1125 3rd Street
Napa, CA 94559

Office: (707) 299-1461

Garrett Veyna
Fire Marshal

MEMORANDUM

TO: Planning Department	DATE: April 30, 2019
FROM: Garrett Veyna Napa County Fire Department	
SUBJECT: P19-00132	APN: Amizetta Winery

The Napa County Fire Marshal's Office has reviewed the submittal package for the above proposed project. The Fire Marshal approves as submitted and requires the following conditions to be incorporated as part of permit issuance.

1. All construction and use of the facility shall comply with all applicable standards, regulations, codes and ordinances at time of Building Permit issuance.
2. Beneficial occupancy will not be granted until all fire department fire and life safety items have been installed, tested and finalized.
3. All buildings, facilities, and developments shall be accessible to fire department apparatus by way of approved access roadways and/or driveways. The fire access road shall comply with the requirements of the Napa County Road & Street Standards.
4. Commercial - Water storage (for buildings not served by a public water system) and fire flow calculations shall be provided by a Certified State Licensed Civil Engineer, C-16 licensed contractor, or registered engineer indicating compliance with Table B105.2 through Table 105.4 of the Napa County Code Amendments.
5. All buildings shall comply with California Fire Code, Chapter 10 Means of Egress requirements. Including but not limited to; exit signs, exit doors, exit hardware and exit illumination.

Please note that the comments noted above are based on a Fire Marshal review only. There may be additional comments or information requested from other County Departments or Divisions reviewing this application submittal package. Napa County Fire Marshal's Office Development Guidelines can be found @ www.countyofnapa.org/firemarshal. Should you have any questions of me, contact me at (707)299-1464 or email at garrett.veyna@fire.ca.gov