

“B”

**Recommended Conditions of Approval
and Final Agency Approval Memos**

Hard Six Cellars Winery P16-00333 & Use Permit Exception to
Conservation Regulations P19-00315
Planning Commission Hearing October 16, 2019

**PLANNING COMMISSION HEARING – OCTOBER 16, 2019
RECOMMENDED CONDITIONS OF APPROVAL**

**Hard Six Cellars Use Permit
Application Number P16-00333-UP, Use Permit Conservation Regulation Request
Application Number P19-00315-UP & Exception to Road and Street Standards
1755 South Fork of Diamond Mountain Road, Calistoga, California
APN #020-100-014**

This permit encompasses and shall be limited to the project commonly known as Hard Six Cellars, located at 1755 South Fork of Diamond Mountain Road. Part I encompasses the Project Scope and general conditions pertaining to statutory and local code references, project monitoring, and the process for any future changes or activities. Part II encompasses the ongoing conditions relevant to the operation of the project. Part III encompasses the conditions relevant to construction and the prerequisites for a Final Certificate of Occupancy. It is the responsibility of the permittee to communicate the requirements of these conditions and mitigations (if any) to all designers, contractors, employees, and guests of the winery to ensure compliance is achieved.

Where conditions are not applicable or relevant to this project, they shall be noted as “Reserved” and therefore have been removed.

When modifying a legally established entitlement related to this project, these conditions are not intended to be retroactive or to have any effect on existing vested rights except where specifically indicated.

PART I

1.0 PROJECT SCOPE

The permit encompasses and shall be limited to:

- 1.1 Approval of a Conservation Regulations Exception to allow re-grading of the existing access driveway to the south fork of Diamond Mountain Road to encroach into the required 55-foot stream setback by approximately 30 to 35 square feet for the unnamed creek.
- 1.2 Approval of an exception to the Napa County Road and Street Standards to the State Responsibility Area Fire Safe Regulations to allow for a reduction in commercial width, a non-standard driveway connection to the nearest public road, and for a portion of road with slopes exceeding 18 percent but less than 20 percent without transition zones (sections of road not exceeding 10 percent for 100 feet in length immediately preceding and ensuing the section of road with the roadway grade of 18 to 20 percent.
- 1.3 Approval of a Use Permit for a 20,000 gallon per year winery to allow the following:
 - a. Construction of a 3,969 square foot two-story (main roof height of approximately 23 feet) winery structure, 7,135 square foot cave, 5,486

- square foot uncovered work area, and 1,185 square foot outdoor hospitality area. A 168 square foot pump house is also proposed;
- b. Removal of an existing barn;
 - c. Visitation, tours and tasting, and a marketing plan as set forth in Conditions of Approval (COAs) Nos. 4.1 through 4.3 below;
 - d. On-premises consumption of wine as set forth in COA No. 4.4 below;
 - e. Hours of operation: 6:00 am to 6:00 pm daily (production hours) and 10:00 am to 6:00 pm Monday through Sunday (visitation hours);
 - f. Maximum number of employees; Four (4) employees (three (3) full time and one (1) part-time) non harvest; two (2) additional employees (two (2) part time) during harvest, for a total maximum of six (6) employees;
 - g. Number of parking spaces; four (4) parking spaces (three (3) standard spaces and one ADA space);
 - h. Installation of a waste water system;
 - i. Installation of a water system (not regulated as small public water system);
 - j. Temporary and/or final location of cave spoils; Majority of spoils will be permanently kept on site and utilized for the restoration of the pond as shown on the project plans while the remaining excess spoils will be transported off-site to a County approved location;
 - k. Improvement of the existing access driveway to County standards except for the request identified in 1.2 above; and
 - l. Construction of one (1) 5,000 gallon water storage tank and one (1) 50,000 gallon fire protection water storage tank (final capacity of fire protection water storage tank may change at time of building permit submittal, but this represents the largest anticipated size for the purposes of project environmental review).

The winery shall be designed in substantial conformance with the submitted site plan, elevation drawings, and other submittal materials and shall comply with all requirements of the Napa County Code (the County Code). It is the responsibility of the permittee to communicate the requirements of these conditions and mitigations (if any) to all designers, contractors, employees, and guests of the winery to ensure compliance is achieved. Any expansion or change in winery use or alternative locations for fire suppression or other types of water tanks shall be approved in accordance with the County Code and may be subject to the permit modification process.

2.0 STATUTORY AND CODE SECTION REFERENCES

All references to statutes and code sections shall refer to their successor as those sections or statutes may be subsequently amended from time to time.

3.0 MONITORING COSTS

All staff costs associated with monitoring compliance with these conditions, previous permit conditions, and project revisions shall be borne by the permittee and/or property owner. Costs associated with conditions of approval and mitigation measures that require monitoring, including investigation of complaints, other than those costs related to investigation of complaints of non-compliance that are determined to be unfounded, shall be charged to the property owner or permittee. Costs shall be as established by resolution of the Board of Supervisors in accordance with the hourly consulting rate established at the time of the monitoring and shall include maintenance of a \$500 deposit for construction

compliance monitoring that shall be retained until issuance of a Final Certificate of Occupancy. Violations of conditions of approval or mitigation measures caused by the permittee's contractors, employees, and/or guests are the responsibility of the permittee.

The Planning Commission may implement an audit program if compliance deficiencies are noted. If evidence of a compliance deficiency is found to exist by the Planning Commission at some time in the future, the Planning Commission may institute the program at the applicant's expense (including requiring a deposit of funds in an amount determined by the Commission) as needed until compliance assurance is achieved. The Planning Commission may also use the data, if so warranted, to commence revocation proceedings in accordance with the County Code.

PART II

4.0 OPERATIONAL CHARACTERISTICS OF THE PROJECT

Permittee shall comply with the following during operation of the winery:

4.1 GENERAL PROVISIONS

Consistent with the County Code, tours and tastings and marketing may occur at a winery only where such activities are accessory and "clearly incidental, related, and subordinate to the primary operation of the winery as a production facility."

Tours and tastings (defined below) may include food and wine pairings, where all such food service is provided without charge except to the extent of cost recovery and is incidental to the tasting of wine. Food service may not involve menu options and meal service such that the winery functions as a café or restaurant.

Retail sales of wine shall be permitted as set forth in the County Code.

4.2 TOURS AND TASTINGS/VISITATION

Tours and tastings shall be by appointment only and shall be limited to the following:

- a. Frequency: seven days per week, Monday through Sunday
- b. Maximum number of persons per day: 16
- c. Maximum number of persons per week: 112
- d. Hours of visitation: 10:00 am to 6:00 pm

"Tours and tastings" means tours of the winery and/or tastings of wine, where such tours and tastings are limited to persons who have made unsolicited prior appointments for tours or tastings. To the maximum extent feasible, scheduling of visitors shall not occur during peak travel times 3:30 PM to 6:00 PM, Monday through Sunday.

A log book (or similar record) shall be maintained to document the number of visitors to the winery (for either tours and tastings or marketing events), and the dates of

the visits. This record of visitors shall be made available to the Planning, Building and Environmental Services (PBES) Department upon request.

4.3 MARKETING

Marketing events shall be limited to the following:

- a. **Type 1**
 1. Frequency: 4 times per year
 2. Maximum number of persons: 75
 3. Time of Day: 11:00 am to 10:00 pm
- b. **Type 2**
 1. Frequency: 1 time per year
 2. Maximum number of persons: 125
 3. Time of Day: 11:00 am to 10:00 pm
- c. Food service to be prepared by licensed caterers.
- d. Marketing events shall not begin nor end during the hours of 3:00 PM to 6:00 PM, Monday through Sunday.
- e. Tours and tastings authorized in COA No. 4.2 shall not occur when Type 2 marketing events are scheduled.

"Marketing of wine" means any activity of a winery which is conducted at the winery on a prearranged basis for the education and development of customers and potential customers with respect to wine which can be sold at the winery on a retail basis pursuant to the County Code. Marketing of wine may include cultural and social events directly related to the education and development of customers and potential customers provided such events are clearly incidental, related and subordinate to the primary use of the winery. Marketing of wine may include food service, including food and wine pairings, where all such food service is provided without charge except to the extent of cost recovery.

Business events are similar to cultural and social events, in that they will only be considered as "marketing of wine" if they are directly related to the education and development of customers and potential customers of the winery and are part of a marketing plan approved as part of the winery's Use Permit. To be considered directly related to the education and development of customers or potential customers of the winery, business events must be conducted at no charge except to the extent of cost recovery, and any business content unrelated to wine must be limited.

Careful consideration shall be given to the intent of the event, the proportion of the business event's non-wine-related content, and the intensity of the overall marketing plan (County Code).

All marketing event activity, excluding quiet clean-up, shall cease by 10:00 pm. If any event is held which will exceed the available on-site parking, the permittee

shall prepare an event-specific parking plan which may include, but not be limited to, valet service or off-site parking and shuttle service to the winery.

Auction Napa Valley (ANV) events need not be included in a participating winery's marketing plan because they are covered by ANV's Category 5 Temporary Permit. The winery may utilize any ANV event authorized in this permit for another charitable event of similar size.

4.4 ON-PREMISES CONSUMPTION

In accordance with State law and the PBES Director's July 17, 2008 memo, "Assembly Bill 2004 (Evans) & the Sale of Wine for Consumption On-Premises," on-premises consumption of wine produced on-site and purchased from the winery may occur solely in the outdoor patio and near the pond. Any and all visitation associated with on-premises consumption shall be subject to the maximum per person weekday and weekend daily tours and tastings visitation limitation and/or applicable limitations of permittee's marketing plan set forth in COA Nos.4.2 and 4.3 above.

4.5 RESIDENCE OR NON-WINERY STRUCTURES

Unless specifically authorized by this permit or a previously approved permit, the existing single-family residence shall not be used for commercial purposes or in conjunction with the operation and/or visitation/marketing program for the winery. If the residence is rented, it shall only be rented for periods of 30 days or more, pursuant to the County Code.

4.6 GRAPE SOURCE

At least 75% of the grapes used to make the winery's still wine or the still wine used by the winery to make sparkling wine shall be grown within Napa County. The permittee shall keep records of annual production documenting the source of grapes to verify that 75% of the annual production is from Napa County grapes. The report shall recognize the Agriculture Commission's format for County of origin of grapes and juice used in the Winery Production Process. The report shall be provided to the PBES Department upon request, but shall be considered proprietary information and not available to the public.

4.7 COMPLIANCE REVIEW

Permittee shall obtain and maintain all permits (use permits and modifications) and licenses from the California Department of Alcoholic Beverage Control (ABC) and United States Tax and Trade Bureau (TTB), and California Department of Food and Agriculture (CDFA) Grape Crush Inquiry data, all of which are required to produce and sell wine. In the event the required ABC and/or TTB permits and/or licenses are suspended or revoked, permittee shall cease marketing events and tours and tastings until such time as those ABC and/or TTB permits and licenses are reinstated.

Visitation log books, visitor reports, custom crush client records, and any additional documentation determined by Staff to be necessary to evaluate compliance may

be requested by the County for any code compliance. The permittee (and their successors) shall be required to participate fully in the winery code compliance review process.

4.8 RENTAL/LEASING

No winery facilities, or portions thereof, including, without limitation, any kitchens, barrel storage areas, or warehousing space, shall be rented, leased, or used by entities other than persons producing and/or storing wine at the winery, such as alternating proprietors and custom producers, except as may be specifically authorized in this Permit or pursuant to the Temporary Events Ordinance (County Code Chapter 5.36).

4.9 GROUND WATER MANAGEMENT - WELLS

This condition is implemented jointly by the Public Works and PBES Departments:

The permittee shall be required (at the permittee's expense) to record well monitoring data (specifically, static water level no less than quarterly, and the volume of water no less than monthly). Such data will be provided to the County, if the PBES Director determines that substantial evidence¹ indicates that water usage at the winery is affecting, or would potentially affect, groundwater supplies or nearby wells. If data indicates the need for additional monitoring, and if the applicant is unable to secure monitoring access to neighboring wells, onsite monitoring wells may need to be established to gauge potential impacts on the groundwater resource utilized for the project. Water usage shall be minimized by use of best available control technology and best water management conservation practices.

In order to support the County's groundwater monitoring program, well monitoring data as discussed above will be provided to the County if the Director of Public Works determines that such data could be useful in supporting the County's groundwater monitoring program. The project well will be made available for inclusion in the groundwater monitoring network if the Director of Public Works determines that the well could be useful in supporting the program.

In the event that changed circumstances or significant new information provide substantial evidence¹ that the groundwater system referenced in the Use Permit would significantly affect the groundwater basin, the PBES Director shall be authorized to recommend additional reasonable conditions on the permittee, or revocation of this permit, as necessary to meet the requirements of the County Code and to protect public health, safety, and welfare.

4.10 AMPLIFIED MUSIC

There shall be no amplified sound system or amplified music utilized outside of approved, enclosed, winery buildings.

¹ Substantial evidence is defined by case law as evidence that is of ponderable legal significance, reasonable in nature, credible and of solid value. The following constitute substantial evidence: facts, reasonable assumptions predicated on facts; and expert opinions supported by facts. Argument, speculation, unsubstantiated opinion or narrative, or clearly inaccurate or erroneous information do not constitute substantial evidence.

4.11 TRAFFIC

To the maximum extent feasible, scheduling of reoccurring vehicle trips to and from the site for employees and deliveries shall not occur during peak travel times (3:00 pm to 6:00 pm weekdays; 3:00 pm to 6:00 pm Saturdays and Sundays). All road improvements on private property required per Engineering Services shall be maintained in good working condition and in accordance with the Napa County Roads and Streets Standards.

4.12 PARKING

The location of visitor parking and truck loading zone areas shall be identified along with proposed circulation and traffic control signage (if any).

Parking shall be limited to approved parking spaces only and shall not occur along access or public roads or in other locations except during harvest activities and approved marketing events. In no case shall parking impede emergency vehicle access or public roads.

4.13 BUILDING DIVISION – USE OR OCCUPANCY CHANGES

Please contact the Building Division with any questions regarding the following:

In accordance with the California Building Code (CBC), no change shall be made in the use of occupancy of an existing building unless the building is made to comply with the requirements of the current CBC for a new building.

4.14 FIRE DEPARTMENT – TEMPORARY STRUCTURES

Please contact the Fire Department with any questions regarding the following:

The permittee and/or designee shall obtain a tent permit from the Fire Department for any temporary structures utilized for authorized marketing events allowed per COA No. 4.3 above.

4.15 NAPA COUNTY MOSQUITO ABATEMENT PROGRAM

The installation, operation and maintenance of the pond shall be in conformance with the Napa County Mosquito Abatement District's program for eliminating mosquito sources and managing mosquito-breeding areas in order to reduce mosquitoes to a tolerable and healthful level.

4.16 GENERAL PROPERTY MAINTENANCE – LIGHTING, LANDSCAPING, PAINTING, OUTDOOR EQUIPMENT STORAGE, AND TRASH ENCLOSURE AREAS

a. All lighting shall be permanently maintained in accordance with the lighting and building plans approved by the County. Lighting utilized during harvest activities is exempt from this requirement.

b. All landscaping and outdoor screening, storage, and utility structures shall be permanently maintained in accordance with the landscaping and building plans approved by the County. No stored items shall exceed the height of the screening.

Exterior winery equipment shall be maintained so as to not create a noise disturbance or exceed noise thresholds in the County Code.

- c. The colors used for the roof, exterior walls and built landscaping features of the winery shall be limited to earth tones that will blend the facility into the colors of the surrounding site specific vegetation. The permittee shall obtain the written approval of the Planning Division prior to any change in paint colors that differs from the approved building permit. Highly reflective surfaces are prohibited.
- d. Designated trash enclosure areas shall be made available and properly maintained for intended use.

4.17 NO TEMPORARY SIGNS

Temporary off-site signage, such as "A-Frame" signs, is prohibited.

4.18 COMPLIANCE WITH OTHER DEPARTMENTS AND AGENCIES – OPERATIONAL CONDITIONS

The attached project conditions of approval include all of the following County Divisions, Departments and Agencies' requirements. Without limiting the force of those other requirements which may be applicable, the following are incorporated by reference as enumerated herein:

- a. Engineering Services Division operational conditions as stated in their Memorandum dated July 17, 2019.
- b. Environmental Health Division operational conditions as stated in their Memorandum dated September 13, 2019.
- c. Building Division operational conditions as stated in their Memorandum dated August 29, 2016.
- d. Department of Public Works operational conditions as stated in their Memorandum dated May 22, 2018.
- e. Fire Department operational conditions as stated in their Inter-Office Memo dated September 4, 2017.

The determination as to whether or not the permittee has substantially complied with the requirements of other County Divisions, Departments and Agencies shall be determined by those County Divisions, Departments or Agencies. The inability to substantially comply with the requirements of other County Divisions, Departments and Agencies may result in the need to modify this permit.

4.19 OPERATIONAL MITIGATION MEASURES

The permittee shall comply with the following operational mitigation measures identified in the adopted Initial Study/Mitigated Negative Declaration and Project Revision Statement/Mitigation Monitoring and Reporting Program prepared for the project:

- a. **MM TRANS-1:** Events at the winery shall not be scheduled to begin or end between 3:00 PM and 6:00 PM to minimize trips during the evening peak hour. A shuttle bus system shall be utilized for events of 125 guests to transport guests from additional temporary parking along vineyard roads and along the shoulders of the winery access road.

Method of Monitoring: A TDM Plan which requires events at the winery to not be scheduled to begin or end between 3:00 PM and 6:00 PM and outlines the shuttle bus system to be used during events of 125 guests shall be prepared and submitted to the Planning Division prior to the issuance of a Final Certificate of Occupancy. After issuance of a Final Certificate of Occupancy, an Ongoing Monitoring and Reporting Statement shall be submitted to the Planning Division on January 15 of each year. Planning Division staff will review the statement to ensure compliance with the TDM Plan. Enforcement steps will be taken, if needed, to attain compliance status.

Responsible Agency: PBES

4.20 OTHER CONDITIONS APPLICABLE TO THE OPERATIONAL ASPECTS OF THE PROJECT **[RESERVED]**

4.21 PREVIOUS CONDITIONS **[RESERVED]**

PART III

5.0 PREREQUISITE FOR ISSUANCE OF PERMITS

5.1 PAYMENT OF FEES

No building, grading or sewage disposal permits shall be issued or other permits authorized until all accrued planning permit processing fees have been paid in full. This includes all fees associated with plan check and building inspections, associated development impact fees established by County Ordinance or Resolution, and the Napa County Affordable Housing Mitigation Fee in accordance with County Code.

6.0 GRADING/DEMOLITION/ENVIRONMENTAL/BUILDING PERMIT/OTHER PERMIT PREREQUISITES

Permittee shall comply with the following with the submittal of a grading, demolition, environmental, building and/or other applicable permit applications.

6.1 COMPLIANCE WITH OTHER DEPARTMENTS AND AGENCIES – PLAN REVIEW, CONSTRUCTION AND PREOCCUPANCY CONDITIONS

The attached project conditions of approval include all of the following County Divisions, Departments and Agencies' requirements. The permittee shall comply

with all applicable building codes, zoning standards, and requirements of County Divisions, Departments and Agencies at the time of submittal and may be subject to change. Without limiting the force of those other requirements which may be applicable, the following are incorporated by reference as enumerated herein:

- a. Engineering Services Division plan review/construction/ preoccupancy conditions as stated in their Memorandum dated July 17, 2019.
- b. Environmental Health Division plan review/construction/ preoccupancy conditions as stated in their Memorandum dated September 13, 2019.
- c. Building Division plan review/construction/ preoccupancy conditions as stated in their Memorandum dated August 29, 2016.
- d. Department of Public Works plan review/construction/ preoccupancy conditions as stated in their Memorandum dated May 22, 2018.
- e. Fire Department plan review/construction/ preoccupancy conditions as stated in their Inter-Office Memo dated September 4, 2017.

The determination as to whether or not the permittee has substantially complied with the requirements of other County Divisions, Departments and Agencies shall be determined by those County Divisions, Departments or Agencies. The inability to substantially comply with the requirements of other County Divisions, Departments and Agencies may result in the need to modify the permit.

6.2 BUILDING DIVISION – GENERAL CONDITIONS

- a. A building permit shall be obtained for all construction occurring on the site not otherwise exempt by the California Building Code (CBC) or any State or local amendment adopted thereto.
- b. If there are any existing structures and/or buildings on the property that will need to be removed to accommodate construction activities, a separate demolition permit shall be required from the Building Division prior to removal. The permittee shall provide a “J” number from the Bay Area Air Quality Management District (BAAQMD) at the time the permittee applies for a demolition permit if applicable.
- c. All areas of newly designed and newly constructed buildings, facilities and on-site improvements must comply with the CBC accessibility requirements, as well as, American with Disability Act requirements when applicable. When alterations or additions are made to existing buildings or facilities, an accessible path of travel to the specific area of alteration or addition shall be provided as required per the CBC.

6.3 LIGHTING – PLAN SUBMITTAL

- a. Two (2) copies of a detailed lighting plan showing the location and specifications for all lighting fixtures to be installed on the property shall be

submitted for Planning Division review and approval. All lighting shall comply with the CBC.

- b. All exterior lighting, including landscape lighting, shall be shielded and directed downward, shall be located as low to the ground as possible, shall be the minimum necessary for security, safety, or operations; on timers; and shall incorporate the use of motion detection sensors to the greatest extent practical. All lighting shall be shielded or placed such that it does not shine directly on adjacent properties or impact vehicles on adjacent streets. No flood-lighting or sodium lighting of the building is permitted, including architectural highlighting and spotting. Low-level lighting shall be utilized in parking areas as opposed to elevated high-intensity light standards. Lighting utilized during harvest activities is exempt from this requirement.

6.4 LANDSCAPING – PLAN SUBMITTAL

- a. Two (2) copies of a detailed final landscaping and irrigation plan, including parking details, shall be submitted with the building permit application package for the Planning Division's review and approval prior to the issuance of any building permit associated with this Use Permit. The plan shall be prepared pursuant to the County's Water Efficient Landscape Ordinance (Chapter 18.118 of the County Code) requirements in effect at the time of building permit application submittal, as applicable, and shall indicate the names and locations of all plant materials to be used along with their method of maintenance.
- b. Plant materials shall be purchased locally when practical, and to the greatest extent possible, the plant materials shall be the same native plants found in Napa County. The Agricultural Commissioner's office shall be notified of all impending deliveries of live plants with points of origin outside of Napa County.
- c. No trees greater than 6" diameter at breast height shall be removed, except for those identified on the submitted site plan. Any Oak trees removed as a result of the project shall be replaced at a 2:1 ratio and shown on the landscaping plans for the Planning Division's review and approval. Trees to be retained shall be protected during construction by fencing securely installed at the outer most dripline of the tree or trees. Such fencing shall be maintained throughout the duration of the work undertaken in connection with the winery development/construction. In no case shall construction material, debris or vehicles be stored in the fenced tree protection area.
- d. Evergreen screening shall be installed between the industrial portions of the operation (e.g. tanks, crushing area, parking area, etc.) and any off-site residence from which these areas can be viewed.

6.5 COLORS

The colors used for the roof, exterior walls and built landscaping features of the winery shall be limited to earth tones that will blend the facility into the colors of the surrounding site specific vegetation. The permittee shall obtain the written approval of the Planning Division in conjunction with building permit review and/or prior to painting the building. Highly reflective surfaces are prohibited.

6.6 OUTDOOR STORAGE/SCREENING/UTILITIES

- a. Details of outdoor storage areas and structures shall be included on the building and landscape plans. All outdoor storage of winery equipment shall be screened from the view of residences of adjacent properties by a visual barrier consisting of fencing or dense landscaping. No stored item shall exceed the height of the screening. Water and fuel tanks, and similar structures, shall be screened to the extent practical so as to not be visible from public roads and adjacent parcels.
- b. New utility lines required for this project that are visible from any designated scenic transportation route (see Community Character Element of the General Plan and the County Code) shall be placed underground or in an equivalent manner be made virtually invisible from the subject roadway.
- c. Exterior winery equipment shall be located, enclosed or muffled so as not to exceed noise thresholds in the County Code.

6.7 TRASH ENCLOSURES

Adequate area must be provided for collection and loading of garbage and recyclables generated by the project. The applicant must work with the franchised garbage hauler for the service area in which they are located, in order to determine the area and the pedestrian and vehicle access needed for the collection site. The garbage and recycling enclosure shall meet the minimum enclosure requirements established by staff and the franchised hauler, which shall be included in the building permit submittal.

6.8 ADDRESSING

All project site addresses shall be determined by the PBES Director, and be reviewed and approved by the United States Post Office. The PBES Director reserves the right to issue or re-issue an appropriate situs address at the time of issuance of any building permit to ensure proper identification and sequencing of I numbers. For multi-tenant or multiple structure projects, this includes building permits for later building modifications or tenant improvements.

6.9 HISTORIC RESOURCES **[RESERVED]**

6.10 DEMOLITION ACTIVITIES

- a. Final demolition plans of the barn shall be submitted for building permit issuance. A site plan prepared by a qualified professional shall denote streams, stream setbacks, existing and proposed improvements and slopes. No new construction or earthmoving activities are allowed within established stream setbacks unless specifically approved as part of this permit in COA

No. 1.0 (Scope) above. As determined by the PBES Director or designee, temporary construction fencing shall be placed at the stream setback line to prevent unauthorized encroachments.

- b. A landscape plan or restoration plan for the demolition area (existing residential and accessory structures) shall be submitted showing how the area will be restored to its natural vegetation state to the extent feasible. The landscape plan shall be approved by the PBES Director or designee prior to installation.

6.11 VIEWSHED – EXECUTION OF USE RESTRICTION [**RESERVED**]

6.12 PERMIT PREREQUISITE MITIGATION MEASURES

The permittee shall comply with the following permit prerequisite mitigation measures identified in the adopted Initial Study/Mitigated Negative Declaration and Project Revision Statement/Mitigation Monitoring and Reporting Program prepared for the project:

- a. **MM BIO-1:** If special-status plant species found on-site cannot be avoided, then a mitigation plan will need to be developed for approval by the California Department of Fish and Wildlife after consultation. The plan shall specify, at a minimum, the following: (1) the location of the mitigation site(s); (2) procedures for procuring plants, such as transplanting or collecting seed from plants to be impacted; (3) procedures for propagating collected seed; (4) the quantity and species of plants to be planted or transplanted; (5) planting procedures, including the use of soil preparation and irrigation; (6) a schedule and action plan to maintain and monitor the mitigation site for a minimum 5 year period; (7) reporting procedures, including the contents of annual progress reports; (8) a list of criteria (e.g., growth, plant cover, survivorship) by which to measure success of the plantings; and (9) contingency measures to implement if the plantings are not successful.

Method of Monitoring: If special-status plant species found on-site cannot be avoided, a mitigation plan approved by the California Department of Fish and Wildlife shall be submitted to Planning Division staff prior to issuance of the grading permit.

Responsible Agency: PBES

- b. **MM BIO-2:** If vegetation clearing or other land disturbance is proposed during the bird breeding season (February 15 through August 31), the work shall be preceded by a survey for special-status bird species and migratory passerines (perching birds) by a qualified biologist within 14 days prior to the beginning of work. In the event that nesting birds are found during the survey, construction buffers shall be established by the biologist in cooperation with the California Department of Fish and Wildlife. These buffers shall remain in place until offspring have fledged or after August 31.

Method of Monitoring: If vegetation clearing or other land disturbance is proposed during the bird breeding season (February 15 through August 31), the special-status bird species and other migratory passerines (perching birds) survey shall be submitted to Planning Division staff prior to issuance of the grading permit.

Responsible Agency: PBES

- c. **MM BIO-3:** A preconstruction survey for western pond turtle shall occur prior to beginning work, and work shall only occur in areas that have been surveyed. This shall include a focused survey for adult turtles and nest site searches. Any adults found within the work area shall be relocated to suitable off-site habitat. Nest sites discovered during the preconstruction survey or anytime during construction shall be avoided until vacated, as determined by a qualified biologist. On-going monitoring during construction shall occur to ensure turtles have not moved back into the area and they are not being impacted by activities. If relocation of a western pond turtle is required, the relocation site must be approved by the California Department of Fish and Wildlife and the biologist relocating the turtle must have approval from the California Department of Fish and Wildlife.

Method of Monitoring: The pre-construction western pond turtle survey shall be submitted to Planning Division staff prior to issuance of the grading permit.

Responsible Agency: PBES

- d. **MM BIO-4:** If any placement of fill within the fresh water marsh of the pond identified in the *Delineation of Potential Jurisdictional Waters Fingerman Property, Calistoga, Napa County, California*, is proposed, consultation and permitting must be obtained from the U.S Regional Water Quality Control Board and California Department of Fish and Wildlife prior to and during the construction.

Method of Monitoring: Proof of the required permits (401 Water Quality Certification from the Regional Water Quality Control Board and 1604 Stream Alteration Agreement from the California Department of Fish and Wildlife) and consultation for any placement of fill within the fresh water marsh of the pond identified in the *Delineation of Potential Jurisdictional Waters Fingerman Property, Calistoga, Napa County, California* from the agencies identified above shall be submitted to Planning Division staff prior to the issuance of a grading permit.

Responsible Agency: PBES

- e. **MM TRANS-2:** Landscaping at the project driveway shall be maintained to not interfere with sight lines required for safe stopping distance on public right-of-way. No items that are wider than 18 inches can be taller than 30 inches other than street trees and traffic devices. Street trees should be deciduous and have branches lower than four feet in height removed once the tree is established.

Method of Monitoring: The final landscape plan shall reflect the implementation of these standards prior to issuance of a building permit.

Responsible Agency: PBES

6.13 PARCEL CHANGE REQUIREMENTS **[RESERVED]**

6.14 FINAL MAPS **[RESERVED]**

6.15 OTHER CONDITIONS APPLICABLE TO THE PROJECT PERMITTING PROCESS **[RESERVED]**

7.0 PROJECT CONSTRUCTION

Permittee shall comply with the following during project construction:

7.1 **SITE IMPROVEMENTS**

Please contact Engineering Services with any questions regarding the following.

a. **GRADING AND SPOILS**

All grading and spoils generated by construction of the project facilities shall be managed per Engineering Services direction. Alternative locations for spoils are permitted, subject to review and approval by the PBES Director, when such alternative locations do not change the overall concept, and do not conflict with any environmental mitigation measures or conditions of approval.

b. **DUST CONTROL**

Water and/or dust palliatives shall be applied in sufficient quantities during grading and other ground disturbing activities on-site to minimize the amount of dust produced. Outdoor construction activities shall not occur when average wind speeds exceed 20 mph.

c. **AIR QUALITY**

During all construction activities the permittee shall comply with the most current version of BAAQMD Basic Construction Best Management Practices including but not limited to the following, as applicable:

1. Post a publicly visible sign with the telephone number and person to contact at the lead agency regarding dust complaints. The BAAQMD's phone number shall also be visible.

2. Water all exposed surfaces (e.g., parking areas, staging areas, soil piles, grading areas, and unpaved access roads) two times per day.
3. Cover all haul trucks transporting soil, sand, or other loose material off-site.
4. Remove all visible mud or dirt traced onto adjacent public roads by using wet power vacuum street sweepers at least once per day. The use of dry power sweeping is prohibited.
5. All vehicle speeds on unpaved roads shall be limited to 15 mph.
6. All roadways, driveways, and sidewalks to be paved shall be completed as soon as possible. Building pads shall be laid as soon as possible after grading unless seeding or soil binders are used.
7. Idling times shall be minimized either by shutting off equipment when not in use or reducing the maximum idling time to five (5) minutes (as required by State Regulations). Clear signage shall be provided for construction workers at all access points.
8. All construction equipment shall be maintained and properly tuned in accordance with manufacturer's specifications. All equipment shall be checked by a certified visible emissions evaluator. Any portable engines greater than 50 horsepower or associated equipment operated within the BAAQMD's jurisdiction shall have either a California Air Resources Board (ARB) registration Portable Equipment Registration Program (PERP) or a BAAQMD permit. For general information regarding the certified visible emissions evaluator or the registration program, visit the ARB FAQ http://www.arb.ca.gov/portable/perp/perpfact_04-16-15.pdf or the PERP website <http://www.arb.ca.gov/portable/portable.htm>.

d. **STORM WATER CONTROL**

The permittee shall comply with all construction and post-construction storm water pollution prevention protocols as required by the County Engineering Services Division, and the California Regional Water Quality Control Board.

7.2 **ARCHEOLOGICAL FINDING**

In the event that archeological artifacts or human remains are discovered during construction, work shall cease in a 50-foot radius surrounding the area of discovery. The permittee shall contact the PBES Department for further guidance, which will likely include the requirement for the permittee to hire a qualified professional to analyze the artifacts encountered and to determine if additional measures are required.

If human remains are encountered during project development, all work in the vicinity must be halted, and the Napa County Coroner informed, so that the Coroner

can determine if an investigation of the cause of death is required, and if the remains are of Native American origin. If the remains are of Native American origin, the permittee shall comply with the requirements of Public Resources Code Section 5097.98.

7.3 CONSTRUCTION NOISE

Construction noise shall be minimized to the greatest extent practical and feasible under State and local safety laws, consistent with construction noise levels permitted by the General Plan Community Character Element and the County Noise Ordinance. Construction equipment muffling and hours of operation shall be in compliance with the County Code. Equipment shall be shut down when not in use. Construction equipment shall normally be staged, loaded, and unloaded on the project site, if at all practicable. If project terrain or access road conditions require construction equipment to be staged, loaded, or unloaded off the project site (such as on a neighboring road or at the base of a hill), such activities shall only occur daily between the hours of 8 am to 5 pm.

7.4 CONSTRUCTION MITIGATION MEASURES [RESERVED]

7.5 OTHER CONSTRUCTION CONDITIONS APPLICABLE TO THE PROJECT PROPOSAL

- a. Pre-construction meeting: No more than two weeks, or as otherwise specified by project mitigation measures. Prior to the commencement of any vegetation removal, earth-disturbing activities, or other development activities associated with this project, the owner/permittee shall schedule an on-site pre-construction meeting that shall include the project planner, owner or owner's agent, plan preparer, contractor(s), and any other parties deemed necessary by Planning Division staff, such as but is not limited to: County Planning and Conservation Division staff and representatives from the Middletown Rancheria. The purpose of this meeting will be to review the development requirements of #P16-00333-UP & #P19-00315-UP including but not limited to: implementation and compliance with project specific conditions of approval and mitigation measures, timing of development activities and pre-construction surveys, and the details of the approved plan. All required protective buffers, including buffer fencing/delineation, shall be installed prior to the pre-construction meeting for inspection by Planning Division staff. Development activities associated with #P16-00333-UP & #P19-00315-UP shall not commence until the owner/permittee has received written clearance from the Planning Division indicating that all pre-construction conditions have been satisfied.

8.0 TEMPORARY CERTIFICATE OF OCCUPANCY - PREREQUISITES

A Temporary Certificate of Occupancy (TCO) may be granted pursuant to the County Code to allow the commencement of production activities prior to completion of all project improvements. Permittee shall comply with the following before a TCO is granted:

8.1 TEMPORARY OCCUPANCY

All life and safety conditions shall be addressed prior to issuance of a TCO by the County Building Official. TCOs shall not be used for the occupancy of hospitality

buildings and shall not exceed the maximum time allowed by the County Code which is 180 days. Departments and/or agencies with jurisdiction over the project are authorized as part of the TCO process to require a security deposit or other financial instrument to guarantee completion of unfinished improvements.

9.0 FINAL CERTIFICATE OF OCCUPANCY – PREREQUISITES

Permittee shall comply with the following before a Final Certificate of Occupancy is granted by the County Building Official, which upon granting, authorizes all use permit activities to commence.

9.1 FINAL OCCUPANCY

All project improvements, including compliance with applicable codes, conditions, and requirements of all Departments and Agencies with jurisdiction over the project, shall be completed.

9.2 SIGNS

Detailed plans, including elevations, materials, color, and lighting for any winery identification or directional signs shall be submitted to the Department for administrative review and approval prior to installation. Administrative review and approval is not required if signage to be installed is consistent with signage plans submitted, reviewed and approved as part of this permit approval. All signs shall meet the design standards as set forth in the County Code. At least one legible sign shall be placed at the property entrance with the words "Tours and Tasting by Prior Appointment Only" to inform the public of same. Any off-site signs allowed shall be in conformance with the County Code.

9.3 GATES/ENTRY STRUCTURES

Any gate installed at the winery entrance shall be reviewed by the PBES Department and the Fire Department to assure that the design allows large vehicles, such as motorhomes, to turn around if the gate is closed without backing into the public roadway, and that fire suppression access is available at all times. If the gate is part of an entry structure an additional permit shall be required pursuant to the County Code and in accordance with the Napa County Roads and Street Standards. A separate entry structure permit is not required if the entry structure is consistent with entry structure plans submitted, reviewed, and approved as part of this permit approval.

9.4 LANDSCAPING

Landscaping shall be installed in accordance with the approved landscaping plan.

9.5 ROAD OR TRAFFIC IMPROVEMENT REQUIREMENTS [RESERVED]

9.6 DEMOLITION ACTIVITIES

All demolition activities associated with the barn shall be completed, landscaping installed, and debris cleared from the subject parcel.

9.7 GRADING SPOILS

All spoils shall be removed in accordance with the approved grading permit and/or building permit.

- 9.8 MITIGATION MEASURES APPLICABLE PRIOR TO ISSUANCE OF A FINAL CERTIFICATE OF OCCUPANCY **[RESERVED]**
- 9.9 OTHER CONDITIONS APPLICABLE PRIOR TO ISSUANCE OF A FINAL CERTIFICATE OF OCCUPANCY **[RESERVED]**



A Tradition of Stewardship
A Commitment to Service

David Morrison
Director

MEMORANDUM

To: Jason Hade, Planning	From: Daniel Basore, Engineering
Date: July 17, 2019	Re: P16-00333 Hard Six Cellars Conditions of Approval - ENG APN: 020-100-014-000

The Engineering Division has reviewed the use permit application P16-00333 for the Hard Six Cellars Winery located on assessor’s parcel number 020-100-014-000. In general the project proposes the following:

New 20,000 gallons Winery, with marketing plan.

Based upon the information provided in the application, Engineering finds the application **complete** and recommends the following conditions of approval:

RECOMMENDED APPROVAL CONDITIONS:

OPERATIONAL CHARACTERISTICS

1. The facility is designated as a discharger that discharges stormwater associated with industrial activity to waters of the United States. Therefore, the facility shall maintain or apply for coverage under the State Water Resources Control Board’s Industrial General Permit (IGP), including meeting all applicable provision and protocols of the IGP. If the facility fails to meet the discharge prohibitions of the IGP, Napa County may require the facility to make the necessary improvements to eliminate all exposures to stormwater of the pollutant(s) for which the water body is impaired.

PREREQUISITES FOR ISSUANCE OF PERMITS

2. All roadway construction associated with this application shall conform to the Road Exception Evaluated composed by this Division, dated July 17, 2019 enclosed herein, and per the accepted construction and inspection practices defined in Federal, State and Local codes. The property owner shall obtain a grading permit for all proposed roadway improvements.
3. Any roadway, proposed new or reconstructed, not included in the above mentioned Road Exception Evaluation shall meet the requirements as outlined in the latest edition of the Napa County Road & Street Standards for Commercial development at the time of use permit approval.

4. All on site civil improvements including but not limited to the excavation, fill, general grading, drainage, curb, gutter, surface drainage, storm drainage, parking and drive isles, shall be constructed according to plans prepared by a registered civil engineer, which will be reviewed and approved by the Engineering Division of the Napa County Planning, Building, and Environmental Services Department (PBES) **prior to the commencement** of any on site land preparation or construction. Plans shall be wet signed and submitted with the building and/or grading permit documents at the time of permit application. A plan check fee will apply.
5. Grading and drainage improvements shall be constructed according to the current Napa County Road and Street Standards, Chapter 16.28 of the Napa County Code, and Appendix J of the California Building Code.
6. **Prior to issuance of a building permit** the owner shall submit the necessary documents for Erosion Control as determined by the area of disturbance of the proposed development in accordance with the Napa Countywide Stormwater Pollution Prevention program Erosion and Sediment Control Plan Guidance for Applicant and Review Staff dated December 2014.
7. **Prior to issuance of a building permit** the owner shall prepare a Regulated Project Stormwater Control Plan (SCP) in accordance with the latest edition of the BASMAA Post-Construction Manual for review and approval by the Engineering Division in PBES.
8. **Prior to issuance of a building permit**, an Operation and Maintenance Plan shall be submitted and tentatively approved by the Engineering Division in PBES. **Before final occupancy** the property owner must legally record the "Operation and Maintenance Agreement", approved by the Engineering Division in PBES.

PREREQUISITES DURING PROJECT CONSTRUCTION

9. Required on-site pre-construction meeting with the Napa County PBES Engineering Division **prior to start of construction**.

PREREQUISITES FOR TEMPORARY CERTIFICATE OF OCCUPANCY

10. All roadway improvements shall be completed **prior to execution** of any new entitlements approved under this Use Permit. **** If no temporary occupancy is requested, then this becomes a requirement prior to final occupancy.**

PREREQUISITES FOR FINAL CERTIFICATION OF OCCUPANCY

11. Operations and Maintenance Agreement for post construction Stormwater facilities must be legally recorded.
12. Site shall be completely stabilized to the satisfaction of the County Engineer prior to Final Occupancy.

Any changes in use may necessitate additional conditions for approval.

If you have any questions regarding the above items, please contact Daniel Basore from Napa County Planning, Building, and Environmental Services Department, Engineering Division, at (707)259-8328 or by email at Daniel.Basore@countyofnapa.org



A Tradition of Stewardship
A Commitment to Service

David Morrison
Director

MEMORANDUM

To: Jason Hade Planning Division	From: Daniel Basore Engineering Services
Date: July 17, 2019	Re: P16-00333 Hard Six Cellars Road Exception Evaluation APN: 020-100-014-000

ROAD EXCEPTION REQUEST:

The Engineering Services Division received a request, dated January 8, 2018 for an exception to the Napa County Road and Street Standards (NCRSS) for the proposed Hard Six Cellars Winery located at 1755 S. Fork Diamond Mountain Road, Calistoga, California 94515.

Access to the subject parcel is achieved via an existing private driveway that serves a single-family residence and vineyards on the subject parcel. The existing private driveway varies in width from 10-12 feet and is approximately 1,050 feet in length to the proposed winery site from Diamond Mountain Road. The driveway has a longitudinal slope that exceeds 20% for approximately 50 feet as it traverses a steep and densely wooded hillside with slopes on either side that exceed 50%.

The Hard Six Cellars project seeks an exception to the NCRSS to allow for a reduction in commercial roadway width, a non-standard driveway connection to the nearest public road, and for a portion of road with slopes exceeding 18% but less than 20% without transition zones*. The request for the exceptions is based on physical constraints (steep slopes, heritage trees, natural water courses), as allowed by the NCRSS Section 3, (d) i.

DRIVEWAY CONNECTION EXCEPTION:

The existing driveway connection has an inside turning radius of six-feet and inside longitudinal slope of approximately 34%. To improve the driveway connection to the standard (P-2 Driveway Connection To Arterial Roads – Rural Roads, Pg. 61 NCRSS) would require mass grading on slopes over 50% and within a Napa County definitional stream setback. It should be noted this grading would also occur outside of the existing 40-foot driveway easement however this was not a consideration in evaluating the exception request. The request was analyzed by the physical constraints (steep slopes, heritage trees, and natural water course) surrounding the driveway.

* transition zones - sections of road not exceeding 10 percent for 100 feet in length immediately preceding and ensuing the section of road with the roadway grade of 18 to 20 percent

P16-00333 HARD SIX CELLARS EXCEPTION EVALUATION

ENGINEERING SERVICE

ROAD EXCEPTION EVALUATION

Page 2 of 3

To provide the same overall practical effect as the NCRSS, the driveway connection is proposed to be improved by widening the inside pavement extents by approximately 10-feet and reducing the inside slope to approximately 18% (from 36%) to allow for a fully loaded fire apparatus to access the driveway in a single turning movement as modelled on the attached *Use Permit Road Exception Request, Road Exception Exhibit, Fire Apparatus Access, UIP 2.0* prepared by the project's civil engineering firm, Delta Consulting and Engineering. In addition, a new caution sign is proposed on Diamond Mountain Road to notify drivers of the driveway intersection and vegetation clearing is also proposed to improve the line of sight to and from the driveway entrance.

COMMERCIAL WIDTH REDUCTION EXCEPTION:

The existing driveway width varies from 10-12 feet and has two blind curves located at approximately station 4+00 and 6+50. In order to improve the driveway to the standard width (20 feet wide with two feet of horizontal clearance) mass grading would be required on slopes over 50% and mature trees would be required to be removed.

To preserve the mature trees and limit disturbance on steep slopes, and provide the same overall practical effect as the NCRSS, the driveway is proposed to be widened to widths that vary between 12 to 22.0 feet. Please refer to attachment A for the full extent of proposed widening. A standard turnout (Detail C-11 NCRSS, pg. 32) through the first blind turn and a non-standard turnout (slightly reduced widths and tapers) through the second blind turn are proposed to improve vision and offer a space for vehicles to pass. Additionally, signage is proposed to notify both the uphill and downhill drivers of the narrowing road conditions, turnout availability, and to assign uphill traffic the right-of-way.

DRIVEWAY GRADE EXCEPTION:

The existing driveway has slopes between 14.6% to 22.3% from station 4+40 to 7+00. This area is proposed to be regraded to have a maximum grade of 19.5%, and exception is being requested for the lack of transition zones for a road slope exceeding 18% but less than 20%. In order to either achieve a road slope of less than 18% or to construct the required transitions zones for grades between 18% and 20%, mass grading would be required on slopes over 50% and mature trees that could otherwise remain would be required to be removed.

ENGINEERING DIVISION EVALUATION AND RECOMMENDATION:

Engineering Division staff has reviewed the Request noted above with the applicant's authorized agents, Engineering staff and the Fire Marshal's office. With respect to Section (3) of the NCRSS as adopted by Resolution No. 2019-053 by the Board of Supervisors on April 23, 2019, this division has determined the following:

The improvement achieves the same overall practical effect of the RSS by providing defensible space and consideration toward life, safety and public welfare by providing the following permanent measures:

1. Horizontal and vertical vegetation management as described in the accompanying Road Exception Request (Attachment A) shall be implemented along the entire length of the private lane and driveway connection to Diamond Mountain Road.
2. Driveway improvements and signage to mitigate traffic concerns in areas receiving exceptions as outlined in Attachment A and described herein.
3. All portions of the driveway not discussed in this Road Exception Evaluation will meet commercial standards as defined in the NCRSS.

The road exception request has provided the necessary documentation as required by RSS Section 3(D) for the Engineering Division to support the Exception Request for approval by the required approving body. The

P16-00333 HARD SIX CELLARS EXCEPTION EVALUATION

ENGINEERING SERVICE

ROAD EXCEPTION EVALUATION

Page 3 of 3

following conditions are in addition to any and all conditions previously placed on the project as part of this discretionary application:

1. The roadway improvements shall be constructed and maintained to the approved condition prior to any new commercial use and/or occupancy and throughout the life of the parcel or until such time the County deems that future road design changes or changes in use of this roadway beyond the use proposed shall require re-evaluation of the roadway to comply with the requirements of adopted codes, standards and regulations and may require additional conditions.
2. The private drive surface shall be periodically maintained by the property owner to assure sufficient structural section for loading conditions equivalent to the H20-44 criterion and the design Traffic Index.

Attachments:

1. Exception Request Letter dated January 8, 2018 prepared by Delta Consulting and Engineering.



January 8, 2018

Patrick Ryan, PE
Engineering Supervisor
Napa County Public Works
1195 Third Street
Napa, California 94559

Subject: Use Permit Road Exception Request
Hard Six Cellars
1755 S. Fork Diamond Mountain Road
Calistoga, CA 94515
APN: 020-100-014

Patrick,

This letter is to request specific exceptions to the November 22, 2016, Napa County Road and Street Standards (RSS) for an existing driveway from Diamond Mountain Road (South Fork) to serve a proposed winery site on the subject parcel noted above. The parcel is currently accessed by a private driveway that ranges in width from 10-12 feet and serves a single-family residence and vineyards. The proposed winery is located along the existing driveway, approximately 1,050 feet distant along the centerline from its intersection with Diamond Mountain Road. This length of driveway traverses a steep and densely wooded hillside where the uphill and downhill cross slope exceeds 50%. In addition, over an approximately 40 foot section of the driveway, the longitudinal slope exceeds 21.5%.

This letter shall be considered a formal request for an exception from the RSS for the access drive based on environmental and/or legal constraints which are described below. Included with this request letter is a set of exhibits from the Revision 2 Use Permit Plan Set titled, "Hard Six Cellars," dated December 18, 2017, which detail the sections of the driveway where it 1) meets the standard, 2) does not meet the standard, 3) areas requiring an exception request, 4) and where mitigation improvements are proposed to allow the drive to meet the same overall practical effects of the RSS.

Road Exception Request Descriptions

Exception #1: Station 0+05 to 0+60

Request for Non-Standard Driveway Apron

Where the driveway meets Diamond Mountain Road (DMR), the existing pavement inside turning radius is approximately six-feet with an inside longitudinal slope of approximately 34%. The limited existing inside turning radius and steep slope are due to a nearly 160-degree turning angle between DMR and the driveway over a narrow driveway apron area. The existing driveway apron width and turning angle are constrained by an approximately 250% uphill cut slope (near vertical) and 80% downhill cross slope. Additionally, the driveway apron is located within a 40-foot wide easement over the adjacent parcel which constrains the extent of improvements available for the initial 170-feet of the driveway.

Improving the driveway to provide a standard 90-degree turning angle with a 20-foot inside turning radius per RSS Detail P-2 would require excessive grading into the 250% cut slope and grading outside of the 40-foot easement boundary. It should further be noted that a Napa County definitional creek is located on the west side of DMR (across DMR from the entrance), and improvements to the driveway apron will require grading within the creek setback. Therefore, due to limited physical space, steep slopes, and easement constraints on both sides of the driveway, installation of a RSS Driveway Apron per Detail P-2 is not feasible.

Proposed Mitigation



To provide the same overall practical effect as the RSS, Hard Six Cellars (HSC) requests to widen the inside pavement extents by approximately 10-feet and reduce the inside slope to approximately 18% while maintaining the existing inside turning radius of six feet. This will allow for a fully loaded fire apparatus to access the driveway in a single turning movement.

To verify the ability of a fire apparatus to access the site, an analysis was conducted using AutoDesk Autoturn with Napa County Fire Truck Parameters (8.0 ft. wide, 30.56 ft. long) to 'drive' the truck into the site based on the mitigated site improvements. Additionally, the brush and tree limbs will be cleared to improve the line of sight and a new caution sign will be installed on DMR to notify drivers of the upcoming driveway intersection. Please reference sheets UP2.0 and UP2.1 in the Road Exception Exhibit for the proposed mitigation measures and an analysis of the truck movement to the site.

Exception Request #2: Station 0+60 to 4+50

Request for Roadway Width Less Than 22 feet.

In this section, the existing driveway width varies from 10-12 feet of paved surface and has a blind curve (#1) between Stations 3+60 and 4+50. To widen the driveway to 22-feet, extensive grading would have to occur on adjacent cross slopes of greater than 50%, tree removal, and an exception to the Conservation Regulations for grading on slopes in excess of 30%.

Proposed Mitigation

HSC requests to widen the driveway to the Maximum Extent Practical by providing a one-foot shoulder beginning on the outside (left side of drive facing up station) top of slope and pave the remaining width to an asphalt curb on the toe of the uphill cut slope to achieve an overall width ranging from 12-20 feet. Additionally, to mitigate the blind corner (#1), HSC proposes to install a County Standard turnout (#1) from station 3+60 to 4+50 (through the blind turn). Brush and tree limbs will be cleared to improve sight distance along the driveway. A notification sign shall be placed at station 0+90 stating to uphill drivers "Road Narrows: Uphill Traffic has Right-of-Way" and another at 4+95 stating to downhill drivers "Turnout Ahead. Uphill Traffic has Right-of-Way. Use Turnouts". The proposed areas of widening to the existing driveway are hatched for easy identification on sheets UP2.1 and UP2.2 of the attached exhibits.

Exception #3, Stations 4+40 to 7+00

Request Roadway Grade of 19.5% without a preceding and ensuing 10% slope

Beginning at station 4+40 and ending at station 7+00, the existing driveway has an average grade of approximately 18.5%; within this section, between station 4+40 and 4+80, the existing roadway has an average centerline grade of approximately 21.5%. The average slope of the 100-feet preceding station 4+40 is approximately 15% and the average slope of the 100-feet ensuing station 7+00 is 15.5%. Either reducing the roadway grade below 18% between stations 4+40 and 7+00 or reducing the roadway grade below 20% between stations 4+40 and 4+80 with a 10% grade for 100-feet preceding and ensuing would require excessive grading into adjacent slopes of greater than 50% requiring an exception to the Conservation Regulations and tree removal. In addition, three trees located immediately at the existing left (facing up-station) edge of pavement between Stations 5+20 and 5+70 are proposed to remain. The trees are: 36" fir, 14" oak, and 16" oak (according to survey). In addition, there is a 60" fir located at the right edge of pavement at approximately Station 6+85 which is also to remain.

Proposed Mitigation

HSC proposes to match the existing road grade of 19.5% at station 4+40, hold that grade to station 4+86, install a 100-foot vertical curve with an ensuing road grade of 17.9%, and hold that grade to station 7+00, where it ties into an existing road grade of 17.9%. The proposed roadway grade profile is provided on sheet UP2.3 of the attached exhibits.

Exception Request #4: Station 4+25 to 8+00:



Request for Roadway Width Less Than 22 feet.

In this section, the existing driveway width varies from 10-12 feet of paved surface and has a blind curve (#2) between Stations 6+30 and 7+10. To widen the common driveway to 22-feet, extensive grading would have to occur on slopes greater than 50% which would require an exception to the Conservation Regulations and tree removal.

Proposed Mitigation

Beginning at the end of the proposed turnout #1 (Station 4+50 as noted in Exception #2 above), widen the driveway to the Maximum Extent Practical (MEP) by providing a one-foot shoulder on the outside/downhill edge and paving the entire width to the toe of the uphill cut slope up to Station 6+52 to provide a width ranging between 14-22 feet. Between Stations 6+25 and 7+10 (blind corner #2), the driveway will be widened to the Maximum Extent Practical to create a non-standard turnout. The widths will range from 19 feet at Station 6+25, to 22 feet at Station 6+50, to approximately 19 feet at Station 6+80. The section between Stations 6+35 – 6+75 will provide approximately 20 feet of width. The turnout is non-standard due to excessive lateral slopes limiting the ability to construct standard tapers and inability to provide the required 22 feet of width at the turnout itself.

From station 6+52 to the end of the exception request area at station 8+00, the driveway daylight to a cut slope on each side. HSC proposes to install curbs on both sides of the driveway and widen to the face of curb to provide a width ranging between 12-22 feet. The proposed areas of widening to the existing driveway are hatched for easy identification on sheets UP2.3 and UP2.4 of the attached exhibits.

A notification sign shall be placed at approximately Station 8+05 stating to the downhill drivers "Road Narrows. Uphill Traffic has Right-of-Way. Use Turnouts".

Beyond Station 8+00, the access drive shall meet the County Standard width and slope requirements for a winery.

Summary

The Applicant proposes to widen the driveway to the Maximum Extent Practical and regrade the centerline slope to a maximum of 19.5% in the areas where the slope exceeds 20% to achieve the same practical effect as if the road met the RSS. Additionally, the applicant proposes to provide a County Standard turnout #1 at the blind curve between stations 3+60 and 4+50, a non-standard turnout #2 between stations 6+25 and 7+10, and install warning traffic signs at stations 0+90, 4+95, and 8+05. All requested exceptions to the RSS are due to avoid the necessity to grade on slopes in excess of 30%, grading adjacent to a creek along Diamond Mountain Road, to preserve the trees in the surrounding environment, and/or due to legal constraints. Other sections of the driveway outside of this road exception request shall meet the Napa County Road and Street Standards dated November 22, 2016.

It is our request that this modification to the Napa County Road and Street Standards be approved with the proposed improvements described above.

Please feel free to contact me if you have any questions.

Sincerely,

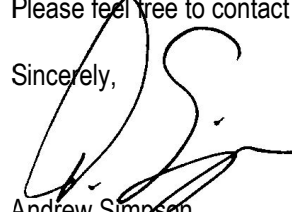

Andrew Simpson
Principal

Attachments

Road Exception Exhibit (11x17 reduced size version of sheets UP2.0 – UP2.6 from Rev2 Use Permit Plan Set)

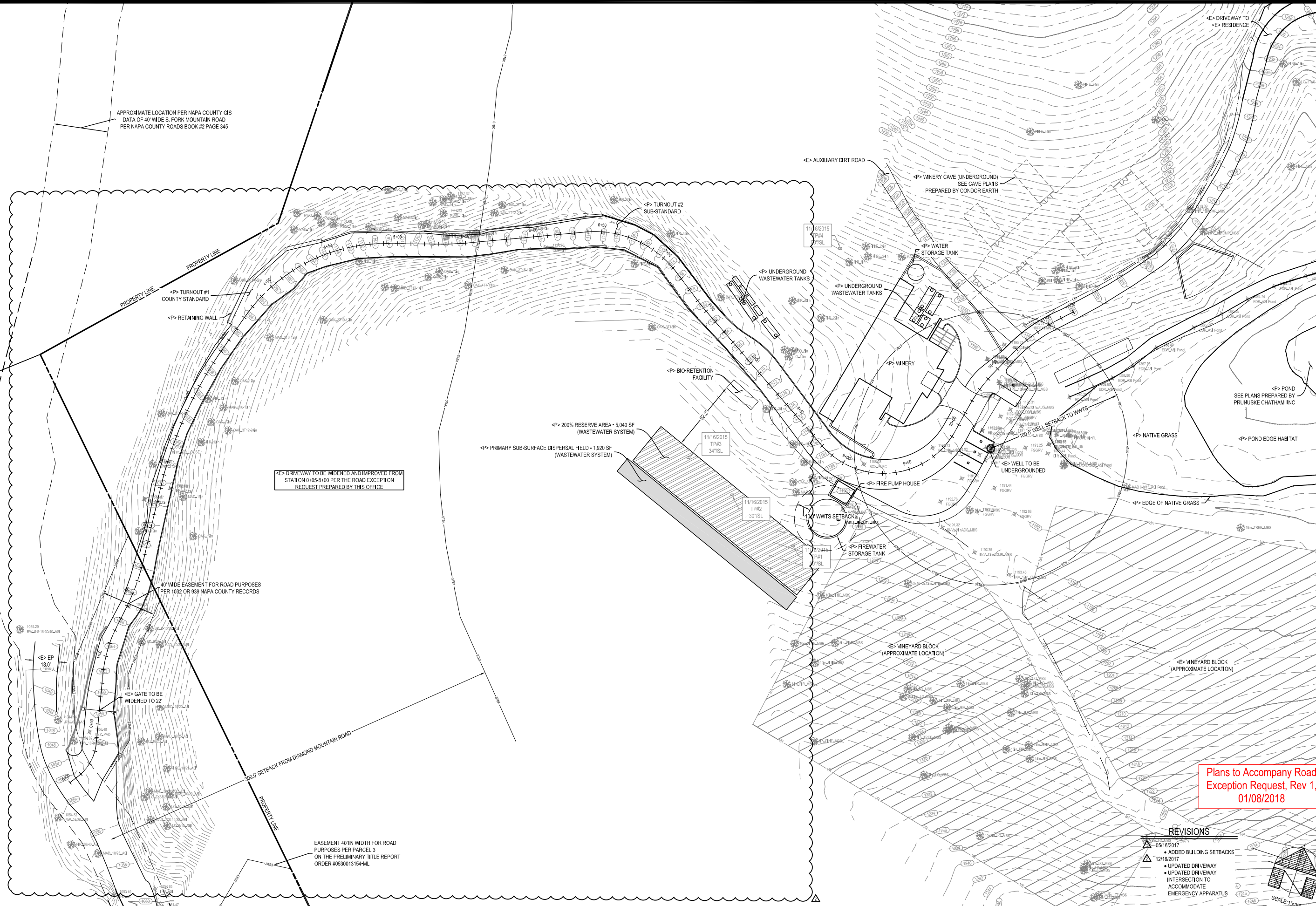

APPROXIMATE LOCATION PER NAPA COUNTY GIS DATA OF 40' WIDE S. FORK MOUNTAIN ROAD PER NAPA COUNTY ROADS BOOK #2 PAGE 345

TURNOUT #1 COUNTY STANDARD

TURNOUT #2 SUB-STANDARD

WINERY CAVE (UNDERGROUND) SEE CAVE PLANS PREPARED BY CONDOR EARTH

WATER STORAGE TANK

UNDERGROUND WASTEWATER TANKS

UNDERGROUND WASTEWATER TANKS

BIO-RETENTION FACILITY

200% RESERVE AREA - 5,040 SF (WASTEWATER SYSTEM)

PRIMARY SUB-SURFACE DISPERSAL FIELD - 1,920 SF (WASTEWATER SYSTEM)

WINERY

FIRE PUMP HOUSE

WELL TO BE UNDERGROUNDED

POND SEE PLANS PREPARED BY PRUNUSKE CHATHAM, INC.

POND EDGE HABITAT

DRIVEWAY TO BE WIDENED AND IMPROVED FROM STATION 0+05+6+00 PER THE ROAD EXCEPTION REQUEST PREPARED BY THIS OFFICE

40' WIDE EASEMENT FOR ROAD PURPOSES PER 1032 OR 939 NAPA COUNTY RECORDS

GATE TO BE WIDENED TO 22'

300.0' SETBACK FROM DIAMOND MOUNTAIN ROAD

EASEMENT 40' IN WIDTH FOR ROAD PURPOSES PER PARCEL 3 ON THE PRELIMINARY TITLE REPORT ORDER #0530013154-MIL

WINERY BLOCK (APPROXIMATE LOCATION)

WINERY BLOCK (APPROXIMATE LOCATION)

Plans to Accompany Road Exception Request, Rev 1, 01/08/2018

REVISIONS

- 05/16/2017 - ADDED BUILDING SETBACKS
- 12/18/2017 - UPDATED DRIVEWAY INTERSECTION TO ACCOMMODATE EMERGENCY APPARATUS

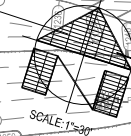

THESE PLANS AND THE INFORMATION CONTAINED HEREON ARE PREPARED BY THE ENGINEER OR ARCHITECT AND NOT TO BE USED FOR ANY OTHER PROJECT WITHOUT THE WRITTEN CONSENT OF THE ENGINEER OR ARCHITECT. THE ENGINEER OR ARCHITECT DOES NOT GUARANTEE THE ACCURACY OF THE INFORMATION CONTAINED HEREON.

DELTA CONSULTING & ENGINEERING OF ST. HELENA 1104 ADAMS STREET, SUITE 203, ST. HELENA, CALIFORNIA 94574 707-963-9456 + 707-963-9528 FAX

USE PERMIT OVERALL SITE PLAN

HARD SIX CELLARS 1755 S. FORK DIAMOND MOUNTAIN ROAD CALISTOGA, CA 94515 APN: 020-100-014 PROJECT: M16



DATE: 06/24/16 ISSUE: PERMIT SET
05/16/17 PLAN CHECK
12/18/17 PLAN CHECK

UP1.2

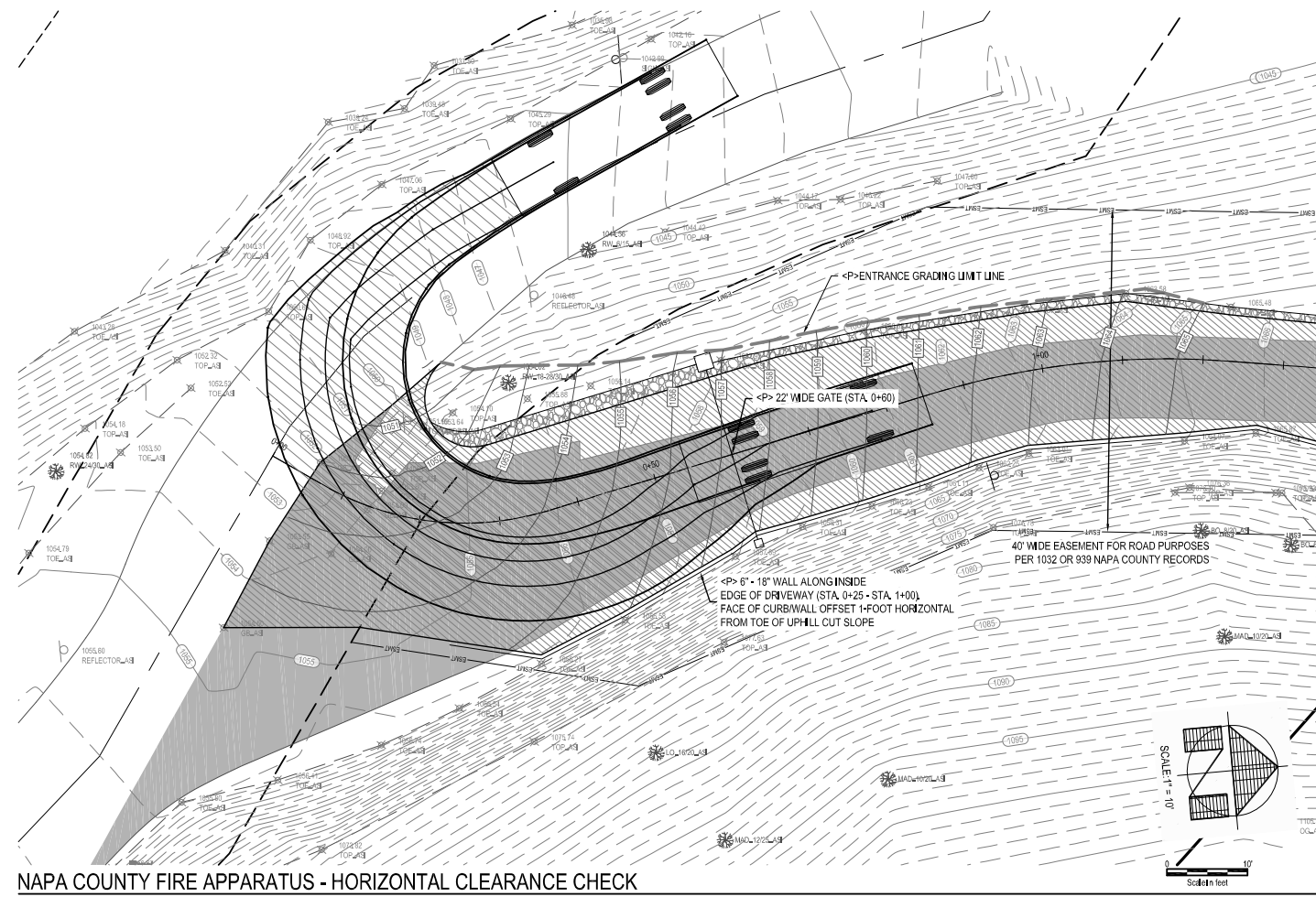

NAPA COUNTY FIRE APPARATUS - HORIZONTAL CLEARANCE CHECK

THE NAPA COUNTY FIRE APPARATUS HORIZONTAL CLEARANCE CHECK WAS MODELED USING AUTOTURN 8.0 DEVELOPED BY TRANSOFT SOLUTIONS
 ADDITIONAL SITE AND DESIGN INFORMATION PROVIDED ON SHEET UP 2.1

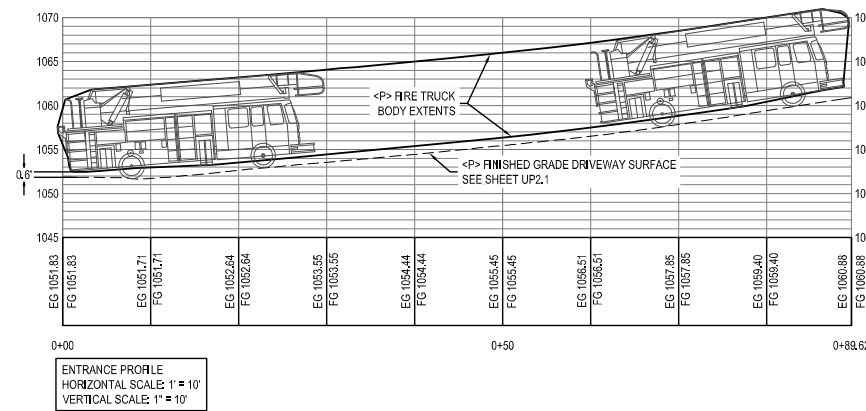

NAPA COUNTY FIRE APPARATUS - VERTICAL CLEARANCE CHECK

THE NAPA COUNTY FIRE APPARATUS VERTICAL CLEARANCE CHECK WAS MODELED USING AUTOCAD 2016 VEHICLE TRACKING

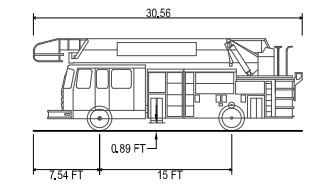

NAPA COUNTY FIRE APPARATUS

OVERALL LENGTH	30.56 FT
OVERALL WIDTH	8.00 FT
OVERALL BODY HEIGHT	10.46 FT
MIN BODY GROUND CLEARANCE	0.89 FT
MAX TRACK WIDTH	7.15 FT
LOOK-TO-LOOK TIME	5.0 S
MAX STEERING ANGLE	40.0°

REVISIONS

12/18/17	NEW SHEET DEDICATED TO FIRE DEPARTMENT ACCESS
----------	-----------------------------------------------

Plans to Accompany Road Exception Request, Rev 1, 01/08/2018

CONTRACTOR'S RESPONSIBILITY: THE CONTRACTOR SHALL BE RESPONSIBLE FOR OBTAINING ALL NECESSARY PERMITS AND FOR VERIFYING THE ACCURACY OF ALL INFORMATION PROVIDED TO THE ENGINEER. THE ENGINEER'S RESPONSIBILITY IS LIMITED TO THE DESIGN AND CONSTRUCTION OF THE PROJECT AS SHOWN ON THESE PLANS. ALL CHANGES TO THE DESIGN SHALL BE MADE BY THE CONTRACTOR. THE CONTRACTOR SHALL BE RESPONSIBLE FOR OBTAINING ALL NECESSARY PERMITS AND FOR VERIFYING THE ACCURACY OF ALL INFORMATION PROVIDED TO THE ENGINEER. THE ENGINEER'S RESPONSIBILITY IS LIMITED TO THE DESIGN AND CONSTRUCTION OF THE PROJECT AS SHOWN ON THESE PLANS. ALL CHANGES TO THE DESIGN SHALL BE MADE BY THE CONTRACTOR.

DELTA CONSULTING & ENGINEERING
 OF ST. HELENA
 1104 ADAMS STREET, SUITE 203, ST. HELENA, CALIFORNIA 94574
 707-963-9486 • 707-963-8528 FAX

USE PERMIT
FIRE APPARATUS ACCESS

HARD SIX CELLARS
 1755 S. FORK DIAMOND MOUNTAIN ROAD
 CALISTOGA, CA 94515
 APN: 020-100-014
 PROJECT: N-116



DATE: 09/24/16
 ISSUE: PERMIT SET
 05/16/17 PLAN CHECK
 12/18/17 PLAN CHECK

UP 2.0

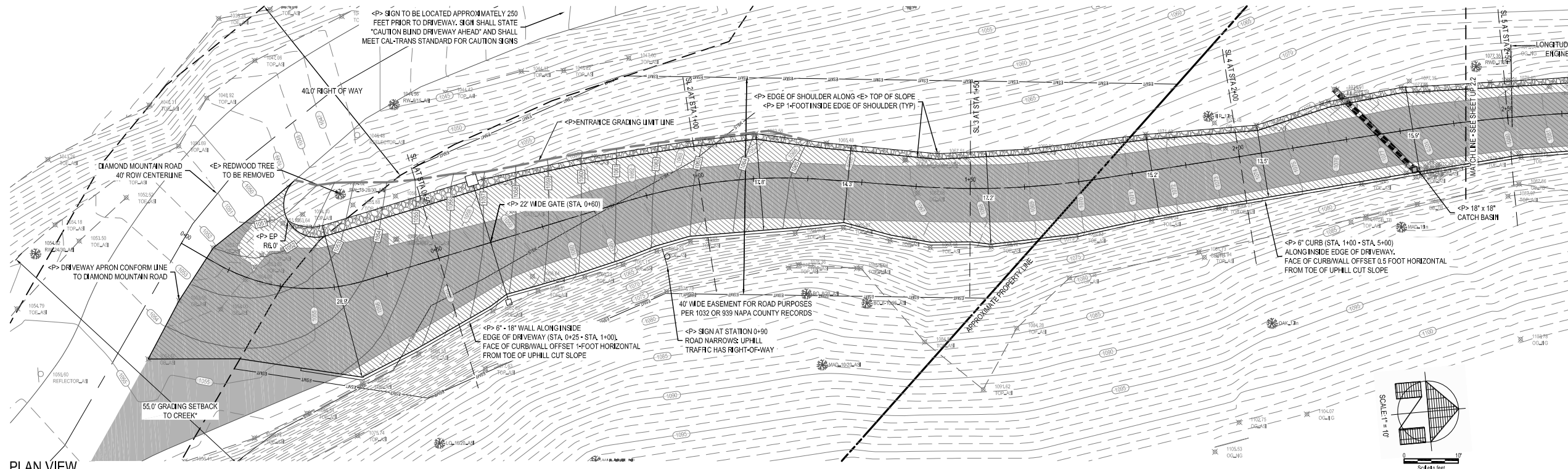

PLAN VIEW

ALL CROSS SECTION VIEWS PROVIDED ON SHEET UP 2.6
 * APPROXIMATE SETBACK SHOWN. GRADING WITHIN THE CREEK SETBACK REQUIRES APPROVED EXCEPTION TO THE NAPA COUNTY CONSERVATION REGULATIONS

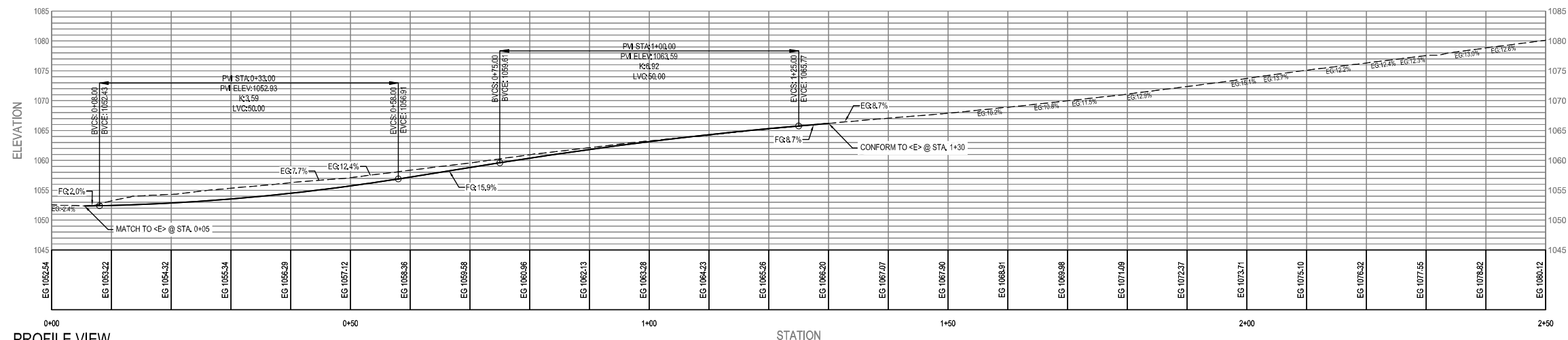

PROFILE VIEW

ROAD EXCEPTION REQUEST TABLE

EXCEPTION #	STATION RANGE	REQUEST	STANDARD*	CONSTRAINT	MITIGATION
1	0+05 - 0+60	NON-STANDARD DRIVEWAY APRON	DRIVEWAY APRON DETAIL P-2	-PHYSICAL SITE LIMITATIONS, ADJACENT CROSS SLOPES >50% -EASEMENT BOUNDARY	-EXISTING APRON TOO NARROW AND STEEP FOR EMERGENCY APPARATUS TO MAKE TURN INTO DRIVEWAY -REGRADE TO PROVIDE ADEQUATE WIDTH AND VERTICAL CURVE FOR EMERGENCY APPARATUS ACCESS
2	0+60 - 4+50	ROAD WIDTH LESS THAN 22 FEET	ROAD WIDTH OF 22-FEET	-PHYSICAL SITE LIMITATIONS, ADJACENT CROSS SLOPES >50%	-EXISTING DRIVEWAY WIDTH VARIES FROM 10-12 FEET WIDE -WIDEN TO MAXIMUM EXTENT PRACTICAL AS SHOWN ON THE PLANS (~14-23 FEET) -CLEAR BRUSH AND LIMBS FROM TREES -INSTALL ONE STANDARD TURNOUT, FROM STA. 3+60 - 4+50, AT BLIND CURVE #1 -INSTALL NARROW ROAD WARNING SIGNAGE
3	4+40 - 7+00	ROAD SLOPE OF 19.5% FOR ~46-FEET WITH >10% SLOPES PRECEDING & ENSUING	-ROAD SLOPE <20% -ROAD SLOPES 18%-20% REQUIRE <10% SLOPE PRECEDING & ENSUING -GRADING TO PROVIDE <18% SLOPE OR <10% SLOPE PRECEDING & ENSUING REQUIRES EXCESSIVE GRADING INTO ADJACENT CROSS SLOPES >50%	-PHYSICAL SITE LIMITATIONS, LONGITUDINAL SLOPE AVERAGE ~21% STA. 4+40 - 4+80 AND ~18.5% STA. 4+40 - 7+00	-REDUCE LONGITUDINAL SLOPE TO 19.5% BEGINNING AT STA. 4+40, INSTALL 100-FT VERTICAL CURVE AND CONFORM TO <E> DRIVEWAY SLOPE = 17.9% BY STA. 7+00
4	4+50 - 8+00	ROAD WIDTH LESS THAN 22 FEET	ROAD WIDTH OF 22-FEET	-PHYSICAL SITE LIMITATIONS, ADJACENT CROSS SLOPES >50%	-EXISTING DRIVEWAY WIDTH VARIES FROM 10-12 FEET WIDE -WIDEN TO MAXIMUM EXTENT PRACTICAL AS SHOWN ON THE PLANS (~14-23 FEET) -CLEAR BRUSH AND LIMBS FROM TREES -INSTALL ONE NON-STANDARD TURNOUT, FROM STA. 6+15 - 6+50, AT BLIND CURVE #2 -INSTALL NARROW ROAD WARNING SIGNAGE

ROAD EXCEPTION NUMBERS CORRELATE WITH THE ROAD EXCEPTION REQUEST LETTER PREPARED BY THIS OFFICE DATED JANUARY 8, 2018. SEE THE ROAD EXCEPTION LETTER FOR A DETAILED DESCRIPTION OF EACH NUMBERED ITEM.

*ALL INFORMATION IN THE "STANDARD" COLUMN IS FROM THE NOVEMBER 22, 2016, VERSION OF THE NAPA COUNTY ROAD AND STREET STANDARDS

DRIVEWAY SURFACE HATCH LEGEND

- EXISTING PAVEMENT
- PROPOSED PAVEMENT/PAVING EXTENTS
- PROPOSED GRAVEL SHOULDER

Plans to Accompany Road Exception Request, Rev 1, 01/08/2018

REVISIONS

- 12/18/17 NEW SHEET, ROAD EXCEPTION REQUEST EXHIBITS NOW INCLUDED IN USE PERMIT PLAN SET FOR CONSISTENCY
- 09/24/16 UPDATED ROAD EXCEPTION REQUEST DESIGN TO CONFORM WITH CURRENT NAPA COUNTY ROAD AND STREET STANDARDS
- 05/16/17 CROSS SECTIONS NOW PROVIDED IN ROAD EXCEPTION REQUEST AREAS
- 12/18/17 UPDATED ROAD EXCEPTION REQUEST TABLE TO REDUCE REDUNDANT LINE ITEMS
- 09/24/16 WIDENED ROAD TO MAXIMUM EXTENT PRACTICAL WITHOUT ENCRoACHING IN ADJACENT CROSS SLOPES >50%
- 12/18/17 ENTRY VERTICAL CURVE DESIGN NOW INCLUDED. SEE SHEET UP 2.0 FOR FIRE TRUCK VERTICAL CLEARANCE CHECK

DELTA CONSULTING & ENGINEERING OF ST. HELENA
 1104 ADAMS STREET, SUITE 203, ST. HELENA, CALIFORNIA 94574
 707-963-9486 + 707-963-8528 FAX

USE PERMIT
 PLAN AND PROFILE

HARD SIX CELLARS
 1755 S. FORK DIAMOND MOUNTAIN ROAD
 CALISTOGA, CA 94515
 APN: 020-100-014
 PROJECT: M116



EVERY PERSON PLANNING TO BUILD CALL US AT 405-252-2880

DATE: 09/24/16
 ISSUE: PERMIT SET
 05/16/17 PLAN CHECK
 12/18/17 PLAN CHECK

UP 2.1

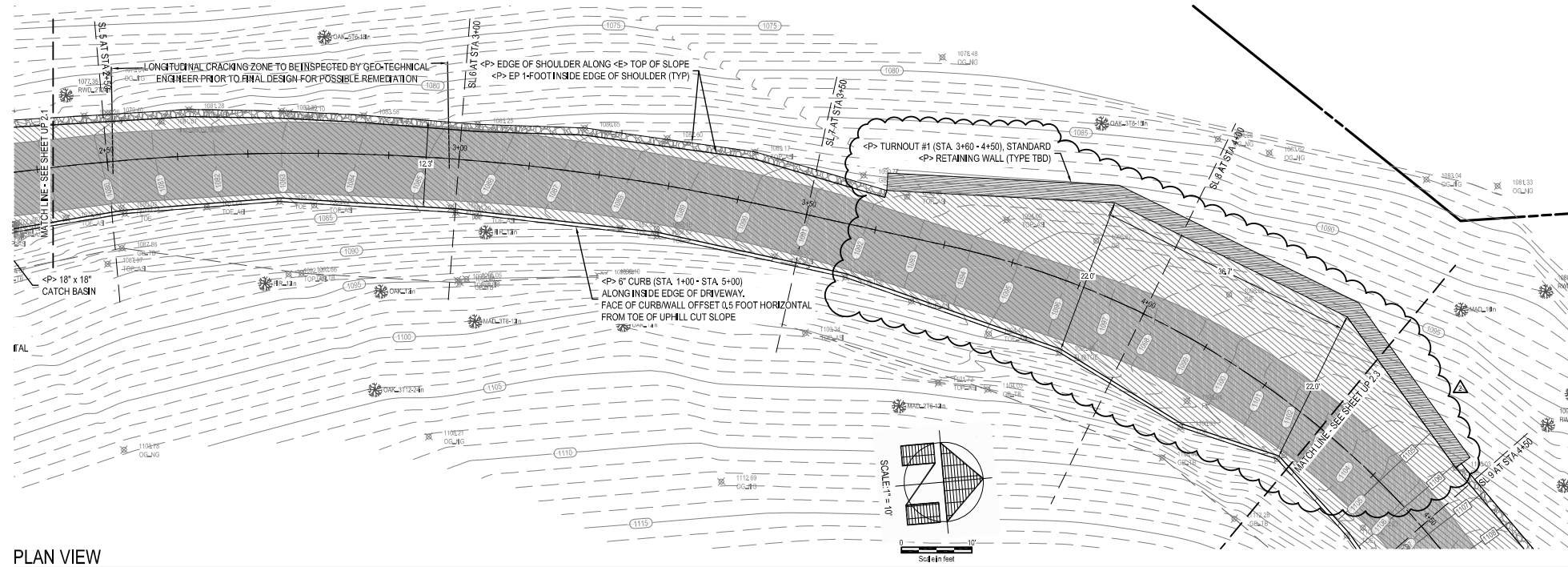

PLAN VIEW

ALL CROSS SECTION MEWS PROVIDED ON SHEET UP 2.6

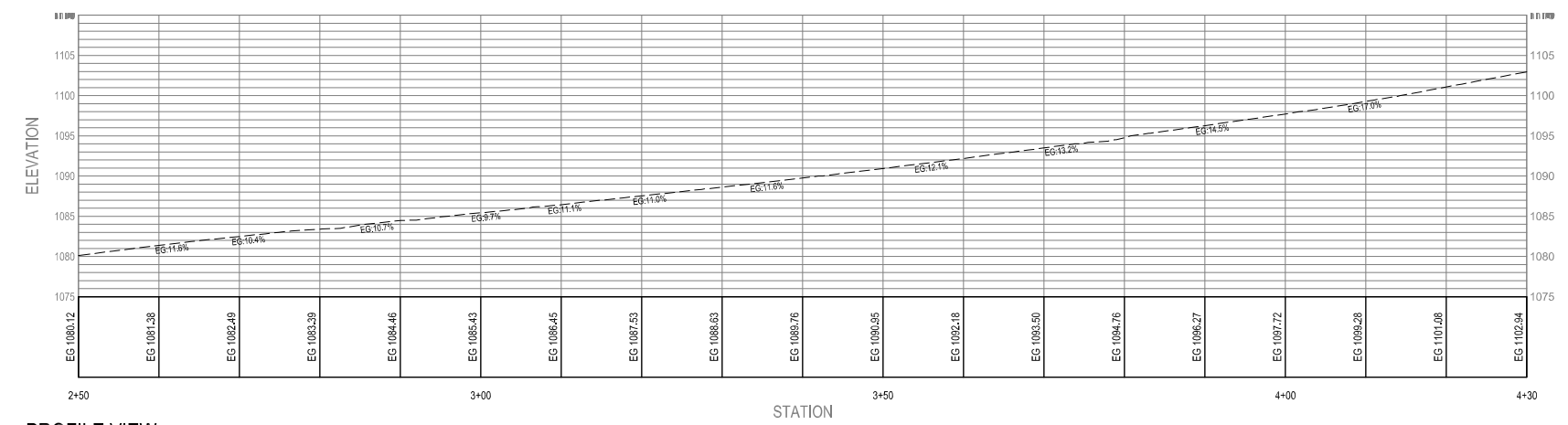

PROFILE VIEW

ROAD EXCEPTION REQUEST TABLE					
EXCEPTION #	STATION RANGE	REQUEST	STANDARD*	CONSTRAINT	MITIGATION
1	0+05 - 0+60	NON-STANDARD DRIVEWAY APRON	DRIVEWAY APRON DETAIL P-2	•PHYSICAL SITE LIMITATIONS. •ADJACENT CROSS SLOPES >50% •EASEMENT BOUNDARY	•EXISTING APRON TOO NARROW AND STEEP FOR EMERGENCY APPARATUS TO MAKE TURN INTO DRIVEWAY •RE-GRADE TO PROMOTE ADEQUATE WIDTH AND VERTICAL CURVE FOR EMERGENCY APPARATUS ACCESS
2	0+60 - 4+50	ROAD WIDTH LESS THAN 22 FEET	ROAD WIDTH OF 22-FEET	•PHYSICAL SITE LIMITATIONS. •ADJACENT CROSS SLOPES >50%	•EXISTING DRIVEWAY WIDTH VARIES FROM 10-12 FEET WIDE •WIDEN TO MAXIMUM EXTENT PRACTICAL AS SHOWN ON THE PLANS (-12-20 FEET). •CLEAR BRUSH AND LIMBS FROM TREES •INSTALL ONE STANDARD TURNOUT, FROM STA. 3+60 - 4+50, AT BLIND CURVE #1 •INSTALL NARROW ROAD WARNING SIGNAGE
3	4+40 - 7+00	ROAD SLOPE OF 18.5% FOR -46-FEET WITH >10% SLOPES PRECEDING & ENSUING	•ROAD SLOPE <20% •ROAD SLOPES 18%-20% REQUIRE <10% SLOPE PRECEDING & ENSUING	•PHYSICAL SITE LIMITATIONS •LONGITUDINAL SLOPE AVERAGE ~21% STA. 4+40 - 4+80 AND ~18.5% STA. 4+40 - 7+00 •GRADING TO PROMOTE <18% SLOPE OR <10% SLOPE PRECEDING & ENSUING REQUIRES EXCESSIVE GRADING TO ADJACENT CROSS SLOPES >50%	•REDUCE LONGITUDINAL SLOPE TO 18.5% BEGINNING AT STA. 4+40, INSTALL 100-FT VERTICAL CURVE AND CONFORM TO <E> DRIVEWAY SLOPE = 17.9% BY STA. 7+00
4	4+50 - 8+00	ROAD WIDTH LESS THAN 22 FEET	ROAD WIDTH OF 22-FEET	•PHYSICAL SITE LIMITATIONS. •ADJACENT CROSS SLOPES >50%	•EXISTING DRIVEWAY WIDTH VARIES FROM 10-12 FEET WIDE •WIDEN TO MAXIMUM EXTENT PRACTICAL AS SHOWN ON THE PLANS (-14-23 FEET). •CLEAR BRUSH AND LIMBS FROM TREES •INSTALL ONE NON-STANDARD TURNOUT, FROM STA. 6+15 - 8+00, AT BLIND CURVE #2 •INSTALL NARROW ROAD WARNING SIGNAGE

DRIVEWAY SURFACE HATCH LEGEND

- EXISTING PAVEMENT
- PROPOSED PAVEMENT/PAVING EXTENTS
- PROPOSED GRAVEL SHOULDER

ROAD EXCEPTION NUMBERS CORRELATE WITH THE ROAD EXCEPTION REQUEST LETTER PREPARED BY THIS OFFICE DATED JANUARY 8, 2018. SEE THE ROAD EXCEPTION LETTER FOR A DETAILED DESCRIPTION OF EACH NUMBERED ITEM.
*ALL INFORMATION IN THE "STANDARD" COLUMN IS FROM THE NOVEMBER 22, 2016, VERSION OF THE NAPA COUNTY ROAD AND STREET STANDARDS

Plans to Accompany Road Exception Request, Rev 1, 01/08/2018

- REVISIONS**
- 12/18/17
 - NEW SHEET, ROAD EXCEPTION REQUEST EXHIBITS NOW INCLUDED IN USE PERMIT PLAN SET FOR CONSISTENCY
 - UPDATED ROAD EXCEPTION REQUEST DESIGN TO CONFORM WITH CURRENT NAPA COUNTY ROAD AND STREET STANDARDS
 - CROSS SECTIONS NOW PROVIDED IN ROAD EXCEPTION REQUEST AREAS
 - UPDATED ROAD EXCEPTION REQUEST TABLE TO REDUCE REDUNDANT LINE ITEMS
 - WIDENED ROAD TO MAXIMUM EXTENT PRACTICAL WITHOUT ENCRDACHING IN ADJACENT CROSS SLOPES >50%
 - MINOR UPDATES TO DRIVEWAY TURNOUT RETAINING WALL LAYOUT TO ENCOMPASS MORE OF BLIND CURVE

THESE PLANS AND SPECIFICATIONS ARE PREPARED BY AN ENGINEER OR ARCHITECT REGISTERED IN THE STATE OF CALIFORNIA. THE REGISTERED PROFESSIONAL SEAL AND SIGNATURE OF THE ENGINEER OR ARCHITECT IS REQUIRED ON THESE PLANS AND SPECIFICATIONS. THE ENGINEER OR ARCHITECT IS NOT RESPONSIBLE FOR THE ACCURACY OF THE INFORMATION PROVIDED TO HIM OR HER BY OTHERS. THE ENGINEER OR ARCHITECT IS NOT RESPONSIBLE FOR THE ACCURACY OF THE INFORMATION PROVIDED TO HIM OR HER BY OTHERS. THE ENGINEER OR ARCHITECT IS NOT RESPONSIBLE FOR THE ACCURACY OF THE INFORMATION PROVIDED TO HIM OR HER BY OTHERS.

DELTA CONSULTING & ENGINEERING
OF ST. HELENA
1104 ADAMS STREET, SUITE 203, ST. HELENA, CALIFORNIA 94574
707-963-9486 • 707-963-8528 FAX

USE PERMIT
PLAN AND PROFILE

HARD SIX CELLARS
1755 S. FORK DIAMOND MOUNTAIN ROAD
CALISTOGA, CA 94515
APN: 020-100-014
PROJECT: N-116



DATE: 08/24/16
ISSUE: PERMIT SET
08/16/17
DATE: 12/18/17
ISSUE: PLAN CHECK
DATE: 12/18/17
ISSUE: PLAN CHECK

UP 2.2

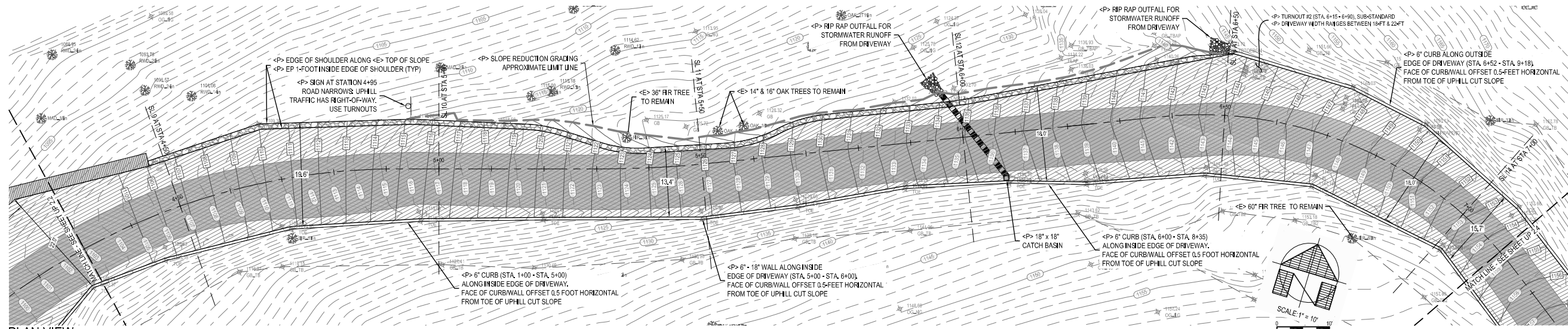

PLAN VIEW

ALL CROSS SECTION MEWS PROVIDED ON SHEET UP 2.6

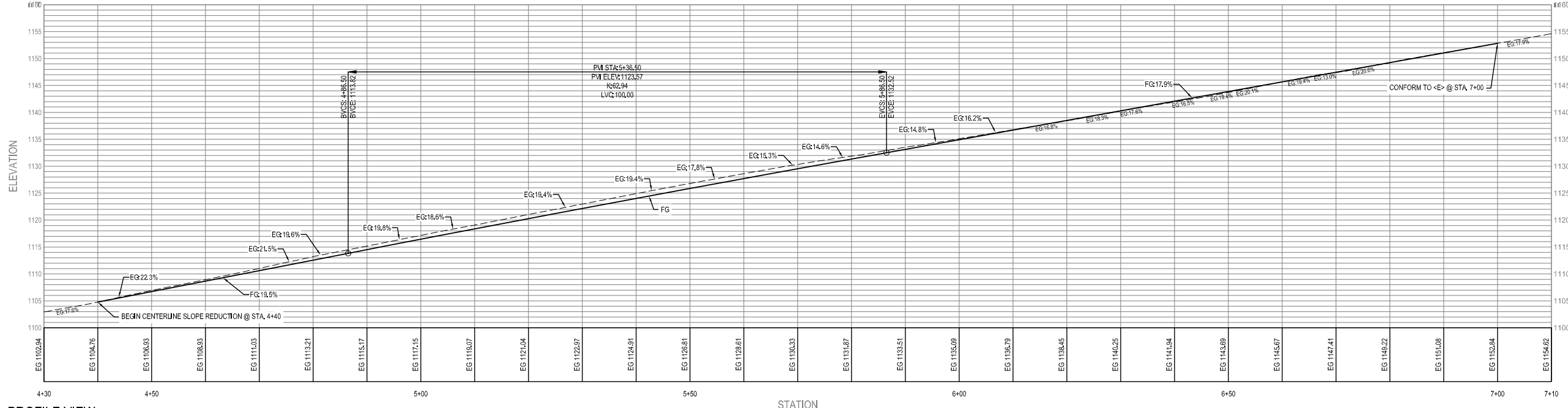

PROFILE VIEW

ROAD EXCEPTION REQUEST TABLE

EXCEPTION #	STATION RANGE	REQUEST	STANDARD*	CONSTRAINT	MITIGATION
1	0+05 - 0+60	NON-STANDARD DRIVEWAY APRON	DRIVEWAY APRON DETAIL P-2	PHYSICAL SITE LIMITATIONS, ADJACENT CROSS SLOPES >50% EASEMENT BOUNDARY	EXISTING APRON TOO NARROW AND STEEP FOR EMERGENCY APPARATUS TO MAKE TURN INTO DRIVEWAY RE-GRADE TO PROVIDE ADEQUATE WIDTH AND VERTICAL CURVE FOR EMERGENCY APPARATUS ACCESS
2	0+60 - 4+50	ROAD WIDTH LESS THAN 22 FEET	ROAD WIDTH OF 22 FEET	PHYSICAL SITE LIMITATIONS, ADJACENT CROSS SLOPES >50%	EXISTING DRIVEWAY WIDTH VARIES FROM 10-12 FEET WIDE WIDEN TO MAXIMUM EXTENT PRACTICAL AS SHOWN ON THE PLANS (-12-20 FEET). CLEAR BRUSH AND LIMBS FROM TREES INSTALL ONE STANDARD TURNOUT, FROM STA. 3+60 - 4+50, AT BLIND CURVE #1 INSTALL NARROW ROAD WARNING SIGNAGE
3	4+40 - 7+00	ROAD SLOPE OF 19.5% FOR 46-FOOT WITH >10% SLOPES PRECEDING & ENSUING	ROAD SLOPE <20% 18%-20% REQUIRE <10% SLOPE PRECEDING & ENSUING	PHYSICAL SITE LIMITATIONS, LONGITUDINAL SLOPE AVERAGE -21% STA. 4+40 - 4+80 AND -18.5% STA. 4+80 - 7+00 GRAVING TO PROVIDE <18% SLOPE OR <10% SLOPE PRECEDING & ENSUING REQUIRES EXCESSIVE GRADING INTO ADJACENT CROSS SLOPES >50%	REDUCE LONGITUDINAL SLOPE TO 19.5% BEGINNING AT STA. 4+40, INSTALL 100-FT VERTICAL CURVE AND CONFORM TO <E> DRIVEWAY SLOPE = 17.9% BY STA. 7+00
4	4+50 - 8+00	ROAD WIDTH LESS THAN 22 FEET	ROAD WIDTH OF 22 FEET	PHYSICAL SITE LIMITATIONS, ADJACENT CROSS SLOPES >50%	EXISTING DRIVEWAY WIDTH VARIES FROM 10-12 FEET WIDE WIDEN TO MAXIMUM EXTENT PRACTICAL AS SHOWN ON THE PLANS (-14-23 FEET). CLEAR BRUSH AND LIMBS FROM TREES INSTALL ONE NON-STANDARD TURNOUT, FROM STA. 6+15 - 6+80, AT BLIND CURVE #2 INSTALL NARROW ROAD WARNING SIGNAGE

ROAD EXCEPTION NUMBERS CORRELATE WITH THE ROAD EXCEPTION REQUEST LETTER PREPARED BY THIS OFFICE DATED JANUARY 8, 2018. SEE THE ROAD EXCEPTION LETTER FOR A DETAILED DESCRIPTION OF EACH NUMBERED ITEM.

*ALL INFORMATION IN THE "STANDARD" COLUMN IS FROM THE NOVEMBER 22, 2016, VERSION OF THE NAPA COUNTY ROAD AND STREET STANDARDS

DRIVEWAY SURFACE HATCH LEGEND

- EXISTING PAVEMENT
- PROPOSED PAVEMENT/PAVING EXTENTS
- PROPOSED GRAVEL SHOULDER

Plans to Accompany Road Exception Request, Rev 1, 01/08/2018

REVISIONS

- 12/18/17
- NEW SHEET. ROAD EXCEPTION REQUEST EXHIBITS NOW INCLUDED IN USE PERMIT PLAN SET FOR CONSISTENCY
- UPDATED ROAD EXCEPTION REQUEST DESIGN TO CONFORM WITH CURRENT NAPA COUNTY ROAD AND STREET STANDARDS
- CROSS SECTIONS NOW PROVIDED IN ROAD EXCEPTION REQUEST AREAS
- UPDATED ROAD EXCEPTION REQUEST TABLE TO REDUCE REDUNDANT LINE ITEMS
- WIDENED ROAD TO MAXIMUM EXTENT PRACTICAL WITHOUT ENCRoACHING IN ADJACENT CROSS SLOPES >50%

DELTA CONSULTING & ENGINEERING
OF ST. HELENA
1104 ADAMS STREET, SUITE 203, ST. HELENA, CALIFORNIA 94574
707-963-9486 • 707-963-8528 FAX

USE PERMIT
PLAN AND PROFILE

HARD SIX CELLARS
1755 S. FORK DIAMOND MOUNTAIN ROAD
CALISTOGA, CA 94515
APN: 020-100-014
PROJECT: M116



EVERY PERSON PLANNING TO BUILD CALL US AT 1-800-225-2880



DATE: 09/24/16
ISSUE: PERMIT SET
09/16/17
DATE: 12/18/17
ISSUE: PLAN CHECK
DATE: 12/18/17
ISSUE: PLAN CHECK

UP 2.3

ROAD EXCEPTION REQUEST TABLE

EXCEPTION #	STATION RANGE	REQUEST	STANDARD*	CONSTRAINT	MITIGATION
1	0+05 - 0+60	NON-STANDARD DRIVEWAY APRON	DRIVEWAY APRON DETAIL P-2	-PHYSICAL SITE LIMITATIONS, ADJACENT CROSS SLOPES >50% -EASEMENT BOUNDARY	-EXISTING APRON TOO NARROW AND STEEP FOR EMERGENCY APPARATUS TO MAKE TURN INTO DRIVEWAY -RE-GRADE TO PROVIDE ADEQUATE WIDTH AND VERTICAL CURVE FOR EMERGENCY APPARATUS ACCESS
2	0+60 - 4+50	ROAD WIDTH LESS THAN 22 FEET	ROAD WIDTH OF 22-FEET	-PHYSICAL SITE LIMITATIONS, ADJACENT CROSS SLOPES >50%	-EXISTING DRIVEWAY WIDTH VARIES FROM 10-12 FEET WIDE -WIDEN TO MAXIMUM EXTENT PRACTICAL AS SHOWN ON THE PLANS (~120 FEET) -CLEAR BRUSH AND LIMBS FROM TREES -INSTALL ONE STANDARD TURNOUT, FROM STA. 3+60 - 4+50, AT BLIND CURVE #1 -INSTALL NARROW ROAD WARNING SIGNAGE
3	4+40 - 7+00	ROAD SLOPE OF 19.5% FOR ~46-FOOT WIDTH >10% SLOPES PRECEDING & ENSLING	-ROAD SLOPE <20% -ROAD SLOPES 18%-20% REQUIRE <10% SLOPE PRECEDING & ENSLING	-PHYSICAL SITE LIMITATIONS, LONGITUDINAL SLOPE AVERAGE ~21% STA. 4+40 - 4+80 AND ~18.5% STA. 4+40 - 7+00 -GRADING TO PROVIDE <18% SLOPE OR <10% SLOPE PRECEDING & ENSLING REQUIRES EXCESSIVE GRADING INTO ADJACENT CROSS SLOPES >50%	-REDUCE LONGITUDINAL SLOPE TO 19.5% BEGINNING AT STA. 4+40, INSTALL 100-FT VERTICAL CURVE AND CONFORM TO <E> DRIVEWAY SLOPE = 17.9% BY STA. 7+00
4	4+50 - 8+00	ROAD WIDTH LESS THAN 22 FEET	ROAD WIDTH OF 22-FEET	-PHYSICAL SITE LIMITATIONS, ADJACENT CROSS SLOPES >50%	-EXISTING DRIVEWAY WIDTH VARIES FROM 10-12 FEET WIDE -WIDEN TO MAXIMUM EXTENT PRACTICAL AS SHOWN ON THE PLANS (~123 FEET) -CLEAR BRUSH AND LIMBS FROM TREES -INSTALL ONE NON-STANDARD TURNOUT, FROM STA. 6+15 - 6+90, AT BLIND CURVE #2 -INSTALL NARROW ROAD WARNING SIGNAGE

ROAD EXCEPTION NUMBERS CORRELATE WITH THE ROAD EXCEPTION REQUEST LETTER PREPARED BY THIS OFFICE DATED JANUARY 8, 2018. SEE THE ROAD EXCEPTION LETTER FOR A DETAILED DESCRIPTION OF EACH NUMBERED ITEM.

*ALL INFORMATION IN THE "STANDARD" COLUMN IS FROM THE NOVEMBER 22, 2016, VERSION OF THE NAPA COUNTY ROAD AND STREET STANDARDS

DRIVEWAY SURFACE HATCH LEGEND

- EXISTING PAVEMENT
- PROPOSED PAVEMENT/PAVING EXTENTS
- PROPOSED GRAVEL SHOULDER

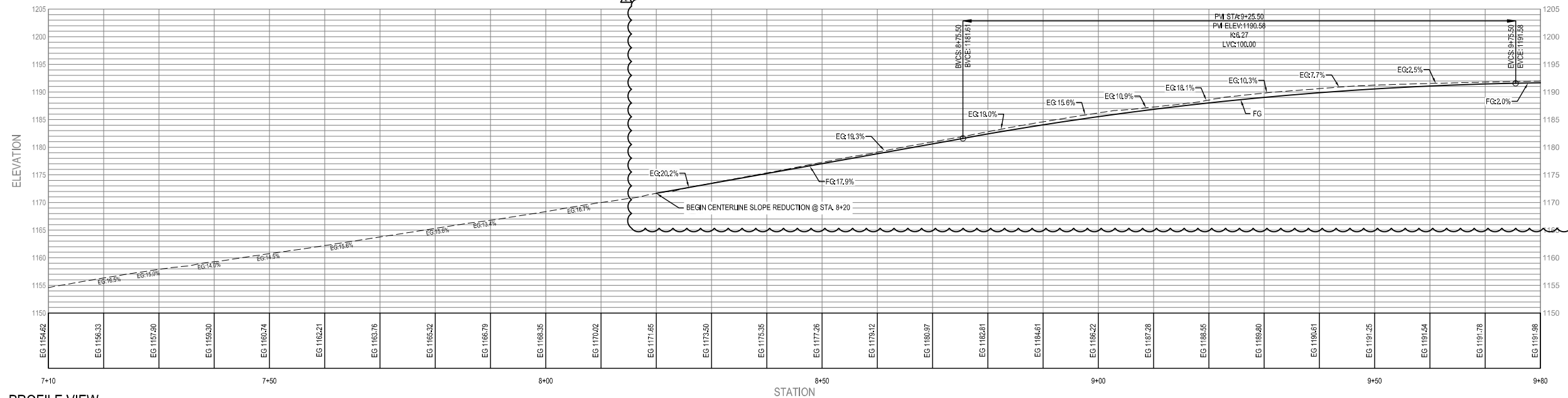
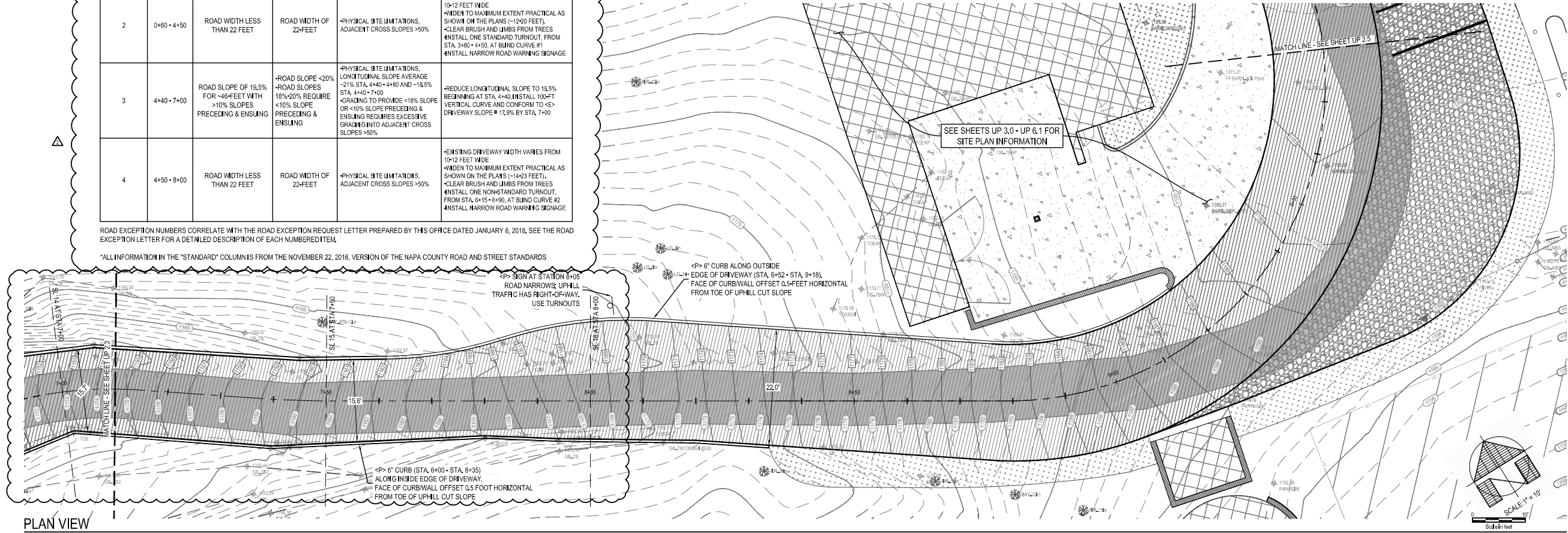

DELTA CONSULTING & ENGINEERING
OF ST. HELENA
1104 ADAMS STREET, SUITE 203, ST. HELENA, CALIFORNIA 94574
707-963-9486 + 707-963-8528 FAX

USE PERMIT
PLAN AND PROFILE

HARD SIX CELLARS
1755 S. FORK DIAMOND MOUNTAIN ROAD
CALISTOGA, CA 94515
APN: 020-100-014
PROJECT: N-116

REGISTERED PROFESSIONAL ENGINEER
ANDREW A. SIMON
No. 62537
Exp. 12-31-19
CIVIL
STATE OF CALIFORNIA

EVERY PERSON PLANNING TO DO
CALL US AT 1-800-225-2880

FOR MORE INFORMATION
SEE WWW.DELTAENGINEERS.COM

Plans to Accompany Road
Exception Request, Rev 1,
01/08/2018

- REVISIONS
- 05/16/17 NO CHANGES THIS SHEET
 - 12/18/17 PREVIOUSLY SHEET UP 2.1
 - SHIFTED START OF SLOPE REDUCTION TO STA. 8+20 TO AVOID SLOPES >18%
 - CROSS SECTIONS NOW PROVIDED IN ROAD EXCEPTION REQUEST AREAS
 - ROAD WIDTH OF 22-FOOT NOW BEGINS AT STA. 8+00 (WAS 20-FOOT & AT STA. 8+35 IN PLAN CHECK #1)
 - UPDATED ROAD EXCEPTION REQUEST TABLE TO REDUCE REDUNDANT LINE ITEMS
 - WIDENED ROAD TO MAXIMUM EXTENT PRACTICAL WITHOUT ENCRoACHING IN ADJACENT CROSS SLOPES >50%

DATE: 09/24/18
ISSUE: PERMIT SET
05/16/17 PLAN CHECK
12/18/17 PLAN CHECK

SHEET
UP 2.4

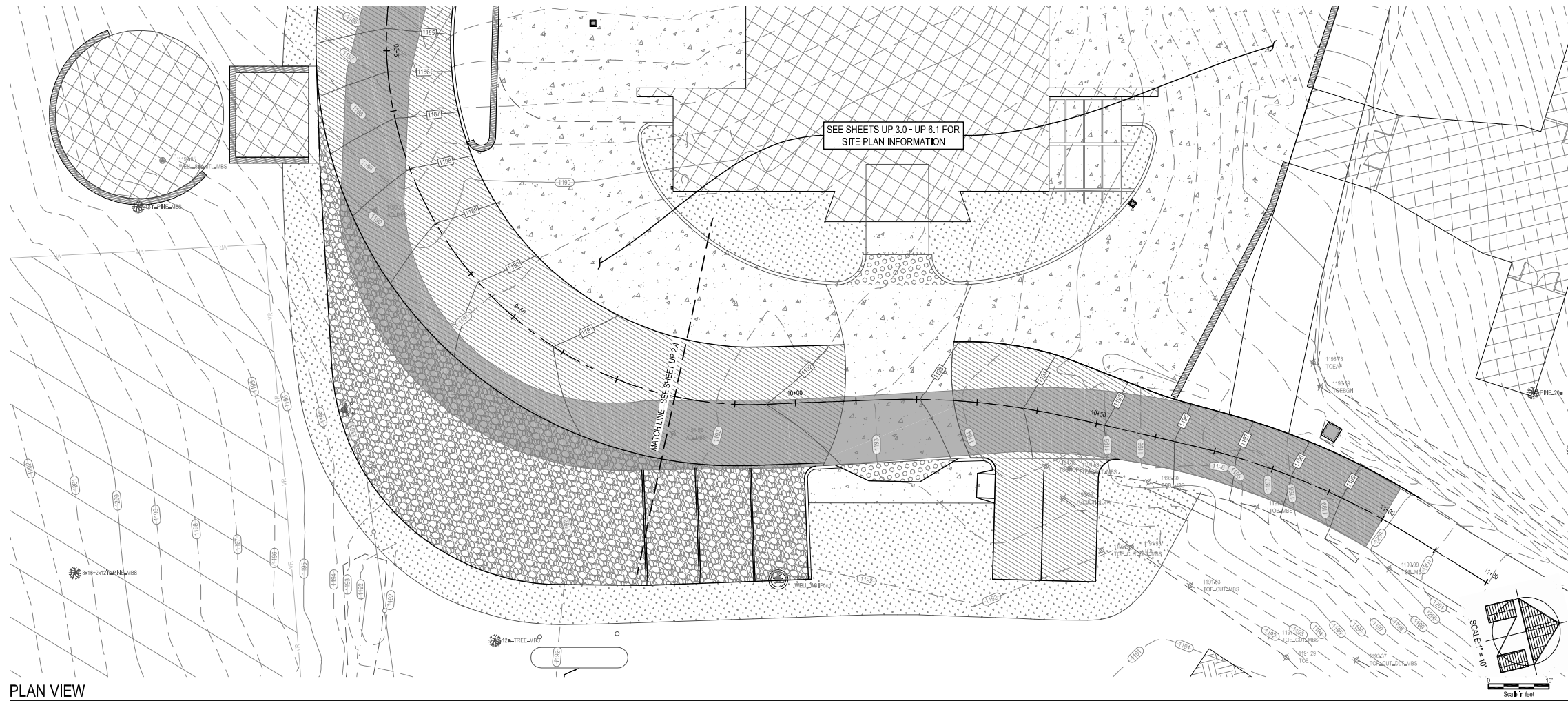

PLAN VIEW

ONLY DRIVEWAY GRADING IMPROVEMENTS SHOWN. FOR SITE GRADING PLAN SEE SHEETS UP 5.0 & UP 5.1

- DRIVEWAY SURFACE HATCH LEGEND**
- EXISTING PAVEMENT
 - PROPOSED PAVEMENT/PAVING EXTENTS
 - PROPOSED GRAVEL SHOULDER

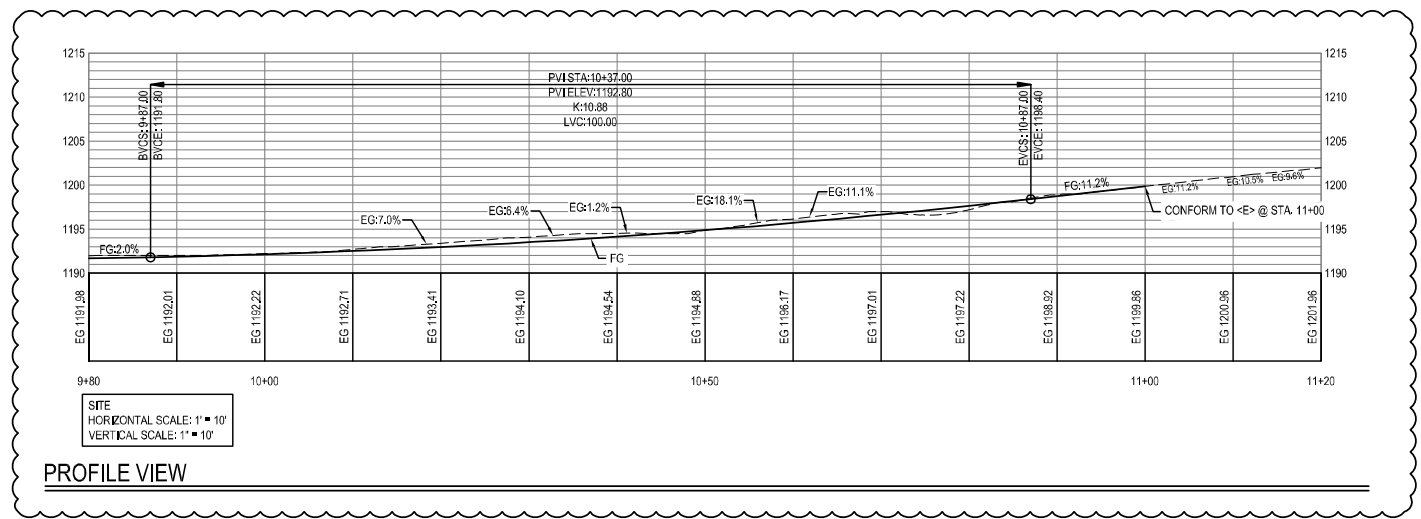

PROFILE VIEW

Plans to Accompany Road Exception Request, Rev 1, 01/08/2018

REVISIONS

DATE	REVISION
05/16/17	NO CHANGES THIS SHEET
12/18/17	PREVIOUSLY SHEET UP 2.2 REDUCED LENGTH REQUIRED TO CONFORM TO <E> DRIVEWAY TO RESIDENCE. PREVIOUSLY STA. 12+35, NOW STA. 11+00

THE USER OF THESE DOCUMENTS IS RESPONSIBLE FOR OBTAINING ALL NECESSARY PERMITS AND FOR VERIFYING THE ACCURACY OF ALL INFORMATION PROVIDED HEREON. THE USER OF THESE DOCUMENTS IS RESPONSIBLE FOR OBTAINING ALL NECESSARY PERMITS AND FOR VERIFYING THE ACCURACY OF ALL INFORMATION PROVIDED HEREON. THE USER OF THESE DOCUMENTS IS RESPONSIBLE FOR OBTAINING ALL NECESSARY PERMITS AND FOR VERIFYING THE ACCURACY OF ALL INFORMATION PROVIDED HEREON.

DELTA CONSULTING & ENGINEERING
OF ST. HELENA
1104 ADAMS STREET, SUITE 203, ST. HELENA, CALIFORNIA 94574
707-963-9456 + 707-963-8528 FAX

USE PERMIT
PLAN AND PROFILE

HARD SIX CELLARS
1755 S. FORK DIAMOND MOUNTAIN ROAD
CALISTOGA, CA 94515
APN: 020-100-014
PROJECT: N-116



DATE: 09/24/16
05/16/17
12/18/17

DESIGN: PERMIT SET
PLAN CHECK
PLAN CHECK

SHEET: **UP 2.5**

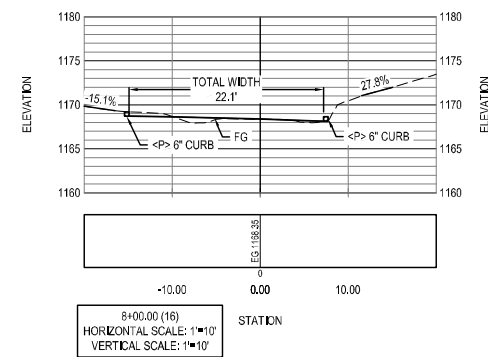
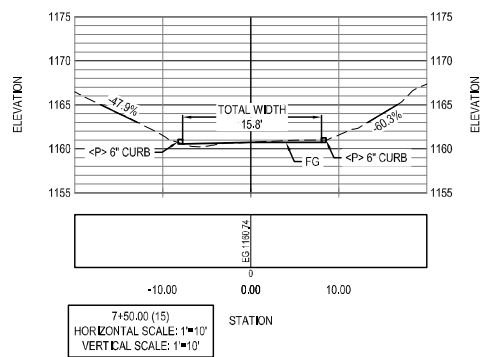
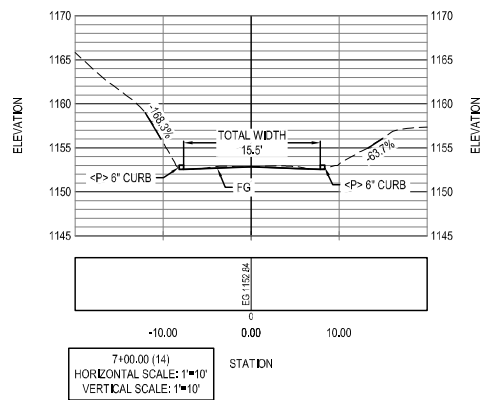
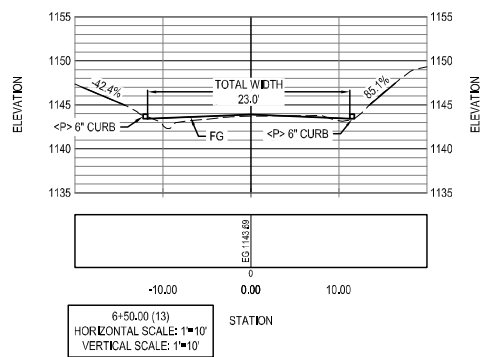
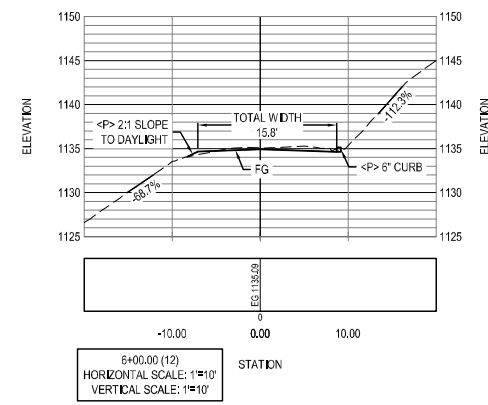
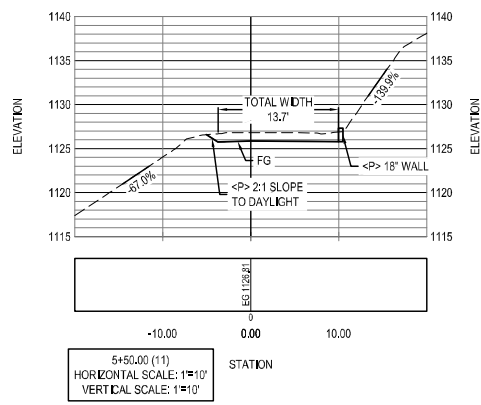
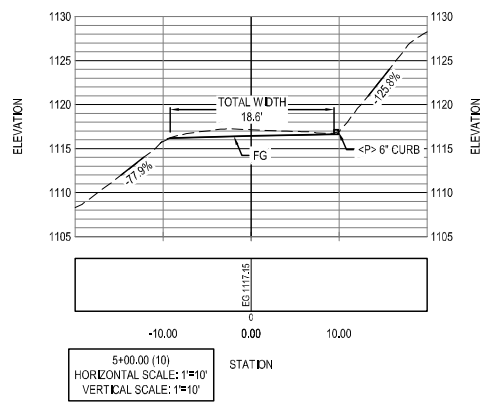
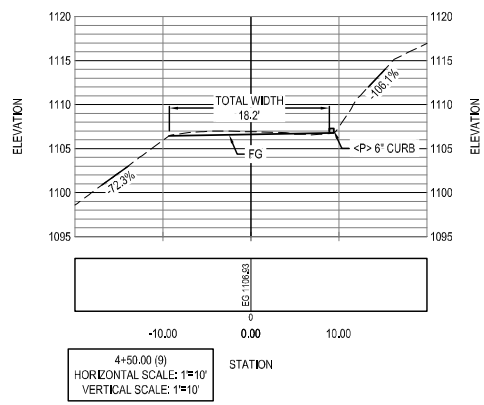
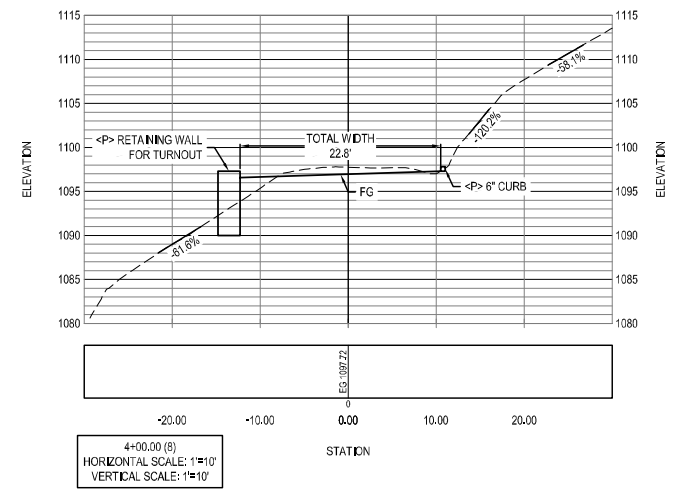
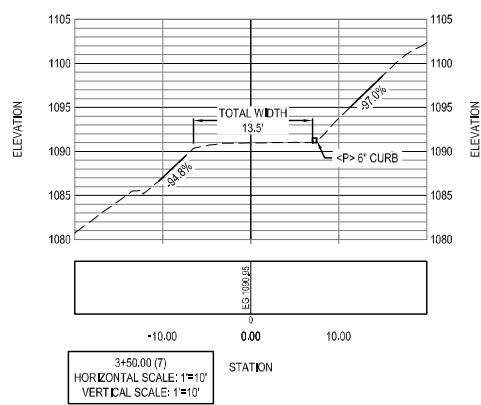
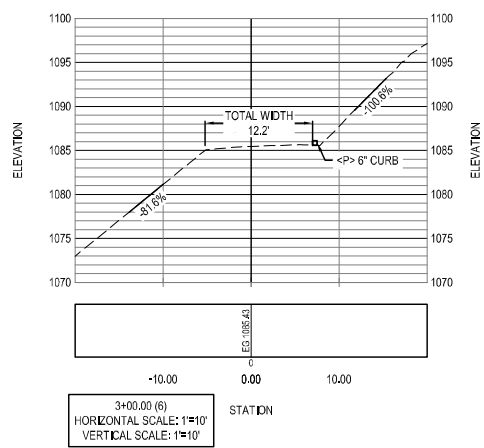
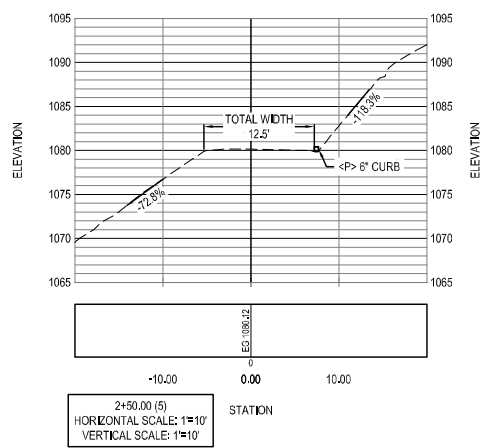
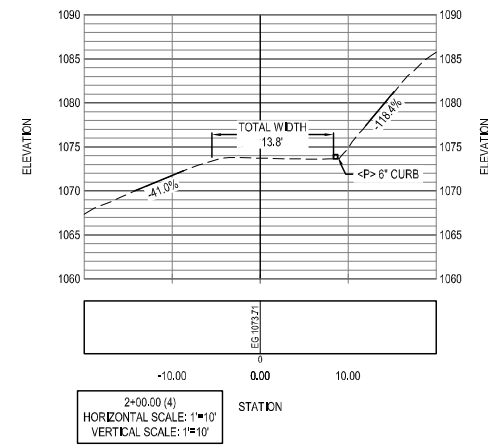
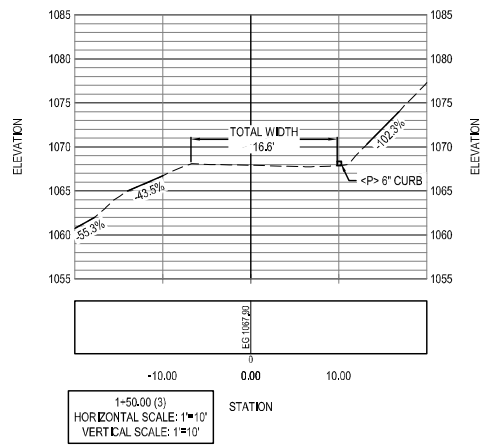
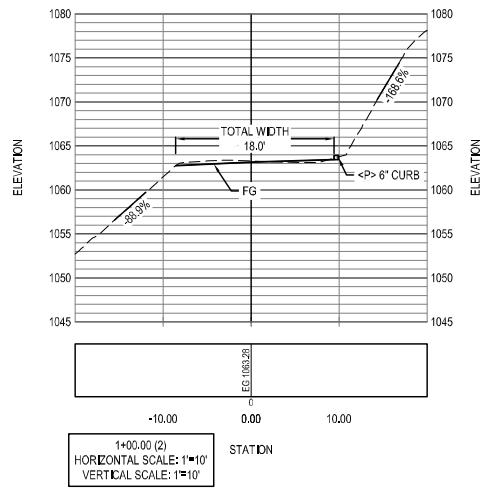
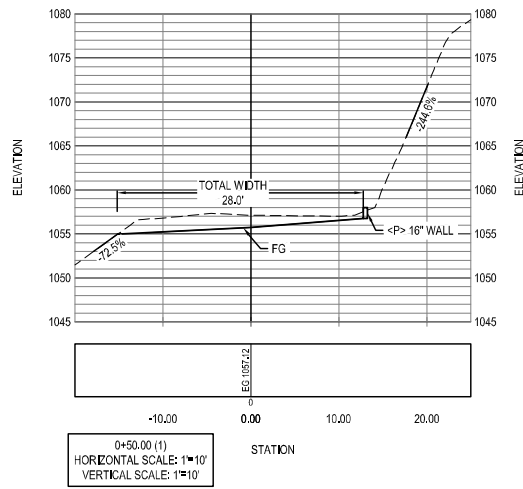

DRIVEWAY CROSS SECTIONS - ROAD EXCEPTION REQUEST AREAS

REVISIONS

12/18/17	NEW SHEET
----------	-----------

Plans to Accompany Road Exception Request, Rev 1, 01/08/2018

THE USER OF THESE DOCUMENTS IS RESPONSIBLE FOR OBTAINING ALL NECESSARY PERMITS AND FOR THE DESIGN AND CONSTRUCTION OF THE PROJECT. THE USER SHALL BE RESPONSIBLE FOR OBTAINING ALL NECESSARY PERMITS AND FOR THE DESIGN AND CONSTRUCTION OF THE PROJECT. THE USER SHALL BE RESPONSIBLE FOR OBTAINING ALL NECESSARY PERMITS AND FOR THE DESIGN AND CONSTRUCTION OF THE PROJECT.

DELTA CONSULTING & ENGINEERING OF ST. HELENA
1104 ADAMS STREET, SUITE 203, ST. HELENA, CALIFORNIA 94574
707-963-9456 • 707-963-8528 FAX

USE PERMIT
DRIVEWAY CROSS SECTIONS

HARD SIX CELLARS
1755 S. FORK DIAMOND MOUNTAIN ROAD
CALISTOGA, CA 94515
APN: 020-100-014
PROJECT: M-16



EVERY PERSON WHO USES THIS CALL US AT 1-800-950-9000

DATE	REVISION
09/24/16	PERMIT SET
05/16/17	PLAN CHECK
12/18/17	PLAN CHECK

SHEET
UP 2.6



A Tradition of Stewardship
A Commitment to Service

Planning, Building & Environmental Services

1195 Third Street, Suite 210
Napa, CA 94559
www.countyofnapa.org

David Morrison
Director

MEMORANDUM

To: Jason Hade, Project Planner	From: Kim Withrow, Environmental Health Supervisor <i>W</i>
Date: September 13, 2019	Re: Hard Six Cellars 1755 South Fork Diamond Mountain Rd APN: 020-100-014 Project #: P16-00333

This Division has reviewed a revised application requesting approval to construct a new winery and related improvements as described and depicted in application materials. This Division has no objection to approval of the application with the following conditions of approval:

Prior to building and/or grading permit issuance:

1. A plan for undergrounding the well that will be located within the parking area must be submitted to this Division for approval. The proposed construction must comply with the Napa County Well Ordinance. A permit and inspection of the work will be required. The applicant shall be advised that a well installed below grade cannot be used to serve a small public water system.
2. A permit to demolish the well located too close to the proposed wastewater treatment area must be obtained by a licensed well drilling contractor.
3. Plans for the proposed alternative sewage treatment system as described in the Wastewater Feasibility Study, dated January 18, 2019, included with application materials shall be designed by a licensed Civil Engineer or Registered Environmental Health Specialist and be accompanied by complete design criteria based upon local conditions. The separation distances prescribed by Napa County Code 13.28.040 shall be met. No building clearance (or issuance of a building permit) for any structure that generates wastewater to be disposed of by this system will be approved until such plans are approved by this Division.

Please be advised-requirements for process wastewater treatment systems in Napa County are being reviewed and may be modified to comply with State Water Quality Control Board (SWQCB) minimum standards.

4. A permit to construct the wastewater treatment system must be secured from this Division prior to approval of a building clearance (or issuance of a building permit) for any structure that generates wastewater to be disposed of by this system.

During construction and/or prior to final occupancy:

5. During the construction, demolition, or renovation period of the project the applicant must use the franchised garbage hauler for the service area in which they are located for all wastes generated during project development, unless applicant transports their own waste. If the applicant transports their own waste, they must use the appropriate landfill or solid waste transfer station for the service area in which the project is located.
6. An annual alternative sewage treatment system monitoring permit must be obtained for the alternative sewage treatment system /private sewage disposal system prior to issuance of a final on the project. The septic system monitoring, as required by this permit, must be fully complied with.

Upon final occupancy and thereafter:

7. The applicant shall provide portable toilet facilities for guest use during events of more than 75 persons as indicated in the septic feasibility report/use permit application. The portable toilet facilities must be pumped by a Napa County permitted pumping company.
8. Pursuant to Chapter 6.95 of the California Health and Safety Code, businesses that store hazardous materials above threshold planning quantities (55 gallons liquid, 200 cubic feet compressed gas, or 500 pounds of solids) shall obtain a permit, file an approved Hazardous Materials Business Plan to <http://cers.calepa.ca.gov/>, and be approved by this Division within 30 days of said activities.
9. Proposed food service will be catered; therefore, any catered food must be prepared and served by a Napa County permitted caterer. If the caterer selected does not possess a valid Napa County Permit to operate, refer the business to this Division for assistance in obtaining the required permit prior to providing any food service.
10. The use of the wastewater absorption field/drain field area shall be restricted to activities which will not contribute to compaction of the soil with consequent reduction in soil aeration. Activities which must be avoided in the area of the septic system include equipment storage, traffic, parking, pavement, livestock, etc.
11. All solid waste shall be stored and disposed of in a manner to prevent nuisances or health threats from insects, vectors and odors.

12. All diatomaceous earth/bentonite must be disposed of in an approved manner. If the proposed septic system is an alternative sewage treatment system the plan submitted for review and approval must address bentonite disposal.

13. The proposed water system to serve this project is not currently required to be regulated as a small public water system by this Division under California Code of Regulations, Title 22, or Napa County Code. Therefore, we have no comment as to its adequacy at this time. The applicant will be required to provide minimal information on the water system prior to approval of a building permit, and may wish to retain the services of a consultant in this matter.



A Tradition of Stewardship
A Commitment to Service

Planning, Building & Environmental Services

1195 Third Street, Suite 210
Napa, CA 94559
www.countyofnapa.org

David Morrison
Director

MEMORANDUM

To: Jason Hade	From: Gary J. West, Chief Building Official
Date: August 26, 2016	Re: Hard Six Cellars Winery Use Permit P16-00333-UP

Building Inspection Division Planning Use Permit Review Comments

Address: 1755 Diamond Mountain Rd., Calistoga CA 94515

APN: 020-100-014-000

Project: Hard Six Cellars Winery Use Permit P16-00333-UP

Owner: Wayne A. & Kara M. Fingerman

Contact: Wayne A. & Kara M. Fingerman/ Donna Olford

Description: Use Permit application to permit the following: 1) 20,000 gallon per year maximum production winery; 2) 7,134 square foot winery cave and 3,767 square foot winery structure with 5,486 square foot covered outdoor work area; 3) Tasting and tours by appointment maximum 16 visitors per day; 4) 5 marketing events per year 75 person maximum; and 5) Three full-time employees, one part-time employee, and two seasonal employees.

Comments: The Building Division is not reviewing this project for compliance with the California Building Standards Codes at this time; the Building Division is reviewing the proposed Planning entitlements only. The Building Division has no issues or concerns with the approval of the Use Permit P16-00333; it is a Planning entitlement and does not in itself authorize any construction activities. Separate building permits shall be required.

The plans provided for Use Permit application P16-00333 do not provide enough information in sufficient detail to determine all code requirements. A complete and thorough plan review will be performed at the time an application is made for the required building, plumbing, mechanical, and electrical and any other construction permits required by other Napa County Agencies. The following

Planning Division
(707) 253-4417

Building Division
(707) 253-4417

Engineering & Conservation
(707) 253-4417

Environmental Health
(707) 253-4471

Parks & Open Space
(707) 259-5933

comments are provided to make the applicant aware of what codes the applicant will be required to comply with, as well as issues that may need to be addressed prior/during the building permit application and review process.

1. In accordance with the California Building Code, Chapter 1, Division 1, Section 1.1.9, which states, "only those standards approved by the California Building Standards Commission that are effective at the time of application for a building permit is submitted shall apply to the plans and specifications for, and to the construction under that permit". The codes adopted at this time are 2013 California Building Standards Codes, Title 24, part 2, Building volumes 1 & 2, part 3 Electrical, part 4 Mechanical, part 5 Plumbing, part 6 Energy, part 9 Fire, and part 11 Green Buildings.
2. If there are any existing structures and/or buildings on the property that will need to be removed to accommodate construction activities a separate demolition permit will be required from the Napa County Building Division prior to the removal. Please note the applicant will be required to provide a "J" number from the Bay Area Quality Management District at the time the applicant applies for a demolition permit if applicable.
3. The site and associated buildings are required to be accessible to persons with disabilities. This includes, but not limited to, a van accessible parking stall, accessible path of travel from the parking stall to all buildings and areas on the site that are available to employees and the public.
4. In accordance with the California Building Code no change shall be made in the use or occupancy of an existing building unless the building is made to comply with the requirements of the California Building Code as for a new building.

Issues of compliance with the California Building Code, Title 24, will be addressed during the building permit application, review and approval process. If the applicant has any questions please have the applicant give me a call at (707)259-8230.

All plans and documents for commercial projects are required by California Law to be prepared and coordinated under the direction of a California Licensed Design Professional, such as an Architect and/or Engineer in accordance with California Business and Professions Code Chapter 3, and the California Building Code, Chapter 1.



GARY J. WEST
CHIEF BUILDING OFFICIAL
NAPA COUNTY BUILDING DIVISION
1195 THIRD STREET
NAPA CA 94559
(707)259-8230
gary.west@countyofnapa.org



A Tradition of Stewardship
A Commitment to Service

Department of Public Works

1195 Third Street, Suite 101
Napa, CA 94559-3092
www.countyofnapa.org/publicworks

Main: (707) 253-4351
Fax: (707) 253-4627

Steven Lederer
Director

MEMORANDUM

To: PBES Staff	From: Janice Spuller Interim Transportation Engineer
Date: May 22, 2018	Re: Hard Six Cellars P16-00333

Thank you for the opportunity to review the subject permit application. I have reviewed the information in the *Traffic Impact Report for the Proposed Hard Six Cellars Winery*, prepared by Crane Transportation Group and dated January 24, 2017. I have also reviewed the previous comment letters from Napa County Public Works (PW) staff dated September 7, 2016, August 22, 2017 and February 22, 2018. The methodologies used and most conclusions reached in the traffic study were approved in September 2016. To address concerns regarding sight distance, on May 7, 2018, I received and reviewed the *Proposed Hard Six Winery-Sight Lines at Driveway Connection to South Fork Diamond Mountain Road Memorandum*, dated March 12, 2018, prepared by Crane Transportation. I offer the following comments from the Department of Public Works:

No further information needed. The memorandum addressed my concerns regarding sight distance.

Left-Turn Lane not required. Based on the forecast of traffic to be generated by the proposed project, and the volume of traffic on South Fork Diamond Mountain Road, this project will not require the installation of a left-turn lane at the location of the project access driveway.

Recommended Conditions of Approval. I offer the following recommended conditions of approval:

- Marketing events should be held at times that preclude adding any new guest traffic to the local circulation system during the peak traffic period. Project Condition: **marketing events of more than 30 visitors shall not begin nor end during the hours of 3-6 PM.**
- Conceptual layout plans show sight lines from the proposed project driveways will meet standards assuming landscaping is maintained in a manner which does not interfere with these sight lines. Project Condition: **landscaping at the project driveways shall be maintained to not interfere with sight lines required for safe stopping distance on public right-of way. No items that are wider than 18 inches can be taller than 30 inches other than street trees and traffic devices. Street trees should be deciduous and have branches lower than 4 feet in height removed once the tree is established.**

Please contact me at Janice.Spuller@countyofnapa.org or call (707) 259-8279 if you have questions or need additional information. Thank you.



A Tradition of Stewardship
A Commitment to Service

Napa County Fire Department
Fire Marshal's Office
Hall of Justice, 2nd Floor
1125 3rd Street
Napa, CA 94559

Office: (707) 299-1461

Garrett Veyna
Fire Marshal

MEMORANDUM

TO: Planning Division	DATE: September 4, 2017
FROM: Garrett Veyna Fire Department	
SUBJECT: P16-00333	APN: 020-100-014

The Napa County Fire Marshal's Office has reviewed the submittal package for the above proposed project. The Fire Marshal approves as submitted and requires the following conditions to be incorporated as part of permit issuance.

1. All construction and use of the facility shall comply with all applicable standards, regulations, codes and ordinances at time of Building Permit issuance.
2. Beneficial occupancy will not be granted until all fire department fire and life safety items have been installed, tested and finalized.
3. Projects shall have an approved water supply for fire protection be made available as soon as combustible material arrives on the site. All underground fire lines, pump and tank plans are required to be a separate submittal from the building or civil plans.
4. Separate submittals required for Underground Fire Lines, Fire Pump, Automatic Fire Sprinklers, Fire Alarm Systems, Kitchen Hood Extinguishing Systems, High Piled Storage (any combustible stored over 12 feet in height).
5. All buildings, facilities, and developments shall be accessible to fire department apparatus by way of approved access roadways and/or driveways. The fire access road shall comply with the requirements of the Napa County Road & Street Standards.
6. Roadways shall be a minimum of 20 feet in width with a 2 foot shoulder and 15 foot vertical clearance.
7. Gates for driveways and/or roadways shall comply with the California Fire Code, section 503.5 and the Napa County Road & Street Standards and CA Fire Safe Regulations for projects within SRA.
8. Commercial - Water storage (for buildings not served by a public water system) and fire flow calculations shall be provided by a Certified State Licensed Civil Engineer, C-16



A Tradition of Stewardship
A Commitment to Service

Napa County Fire Department
Fire Marshal's Office
Hall of Justice, 2nd Floor
1125 3rd Street
Napa, CA 94559

Office: (707) 299-1461

Garrett Veyna
Fire Marshal

MEMORANDUM

licensed contractor, or registered engineer indicating compliance with **Table B105.2 through Table 105.4 of the Napa County Code Amendments.**

9. Commercial - 1. Common driveways shall provide two 10 foot traffic lanes and one for of shoulder on either side (total horizontal width of 22 feet). The plans and exception request refer to a 20 foot wide drive which is not consistent with the Napa County Road and Street Standards (RSS), revise all documents as necessary. Private fire service mains shall be installed, tested and maintained per NFPA 24 2013 edition.
10. Commercial - **Fire Department Connections (FDC)** for automatic sprinkler systems shall be located fully visible and recognizable from the street or fire apparatus access roads. FDC shall be located within 50 feet of an approved fire hydrant.
11. Commercial - The minimum main size of all fire hydrants shall be 6 inches in diameter. Piping shall be installed with C-900 class 200 piping or ductile iron or equivalent per NFPA 24, 2013 edition for the installation of Underground Fire Protection Mains.
Indicate on plan set.
12. An automatic fire sprinkler system shall be installed in accordance with provisions set forth in the California Fire Code as amended by the County of Napa and the applicable National Fire Protection Association Standard. Automatic fire sprinkler systems shall be designed by a fire protection engineer or C-16 licensed contractor.
13. All buildings shall comply with California Fire Code, Chapter 10 Means of Egress requirements. Including but not limited to; exit signs, exit doors, exit hardware and exit illumination.
14. Provide 100 feet of defensible space around all structures.
15. Provide 10 feet of defensible space fire hazard reduction on both sides of all roadways of the facility..
16. All cave development shall comply with CBC Section 436 as well as the Napa County Fire Marshal's Office Cave Development Guidelines.

Please note that the comments noted above are based on a Fire Marshal review only. There may be additional comments or information requested from other County Departments or Divisions reviewing this application submittal package. Napa County Fire Marshal's Office



A Tradition of Stewardship
A Commitment to Service

Napa County Fire Department
Fire Marshal's Office
Hall of Justice, 2nd Floor
1125 3rd Street
Napa, CA 94559

Office: (707) 299-1461

Garrett Veyna
Fire Marshal

MEMORANDUM

Development Guidelines can be found @ www.countyofnapa.org/firemarshal. Should you have any questions of me, contact me at (707)299-1461 or email at garrett.veyna@fire.ca.gov