

RECEIVED

JUL 21 2009

All application materials are as revised by the March 2010 plan set

FILE # 89-00329 & TPM 89-00330



NAPA CO. CONSERVATION DEVELOPMENT & PLANNING DEPT.

NAPA COUNTY

CONSERVATION, DEVELOPMENT & PLANNING DEPARTMENT

1195 Third Street, Suite 210, Napa, California, 94559 • (707) 253-4417

APPLICATION FOR USE PERMIT

FOR OFFICE USE ONLY

ZONING DISTRICT: IP:2C Date Submitted: 7.21.09

REQUEST: USE PERMIT TO ALLOW CONSTRUCTION & OPERATION OF

5 OFFICE BUILDINGS TOTALING 113,136 SF & 3 WAREHOUSE BLDG.S TOTALING 385,335 SF. THE PROJECT ALSO INCLUDES AN 11

LOT TENT. PARCEL MAP (89-00330), A VARIATION TO Q1ASP.

DEV. STANDARDS TO ALLOW A DRIVEWAY TO BE CONSTRUCTED ON AVIATION WAY, A LOT LINE ADJ. & A STORMWATER WAIVER

ON AVIATION WAY, A LOT LINE ADJ. & A STORMWATER WAIVER

HAIRPORT BLVD. Hearing Action

ZA CDPC BS APPEAL

Hearing

Action

TO BE COMPLETED BY APPLICANT (Please type or print legibly)

Applicant's Name: Napa 34 Holdings LLC - Brian Kaufman, Member

Telephone #: (916) 920 - 4900 Fax #: (916) 920 - 8906 E-Mail: bkaufman@wallerkaufmansutter.com

Mailing Address: 2617 Castro Street Sacramento CA 95818

Status of Applicant's Interest in Property: Member, LLC

Property Owner's Name: Napa 34 Holdings LLC - Brian Kaufman, Member

Telephone #: () - Fax #: () - E-Mail:

Mailing Address: Same as above

Site Address/Location: Approximately 34 acre parcel at southwest corner of Airport Blvd. and SR 29, between SR 29 and future southern extension of Devlin Road

Assessor's Parcel #: 057-210-056 Existing Parcel Size: Approx. 34 Acres

I certify that all the information contained in this application, including but not limited to the information sheet, water supply/waste disposal information sheet, site plan, floor plan, building elevations, water supply/waste disposal system site plan and toxic materials list, is complete and accurate to the best of my knowledge. I hereby authorize such investigations including access to County Assessor's Records as are deemed necessary by the County Planning Division for preparation of reports related to this application, including the right of access to the property involved.

Signature of Applicant: Brian Kaufman Date: 6/23/09

Signature of Property Owner: Brian Kaufman Date: 6/23/09

TO BE COMPLETED BY CONSERVATION, DEVELOPMENT AND PLANNING DEPARTMENT

*Application Fee Deposit: \$ Receipt No. Received by: Date:

*Total Fees will be based on actual time and materials

ALTERNATE CONTACT- BRAD SHIRHALL, TL&A ENG. & PLAN., 916-786-0685, bshirhall@tl&a-inc.com

IV. TYPICAL OPERATION	<u>Existing</u>	<u>Proposed</u>
A. Days of Operation:	<u>Zero</u>	<u>5 to 6</u>
B. Expected Hours of Operation:	<u>Zero</u>	<u>8 to 10/day</u>
C. Anticipated Number of Shifts:	<u>Zero</u>	<u>1</u>
D. Expected Number of Full-Time Employees/Shift:	<u>Zero</u>	<u>583</u>
E. Expected Number of Part-Time Employees/Shift:	<u>Zero</u>	<u>33</u>
F. Anticipated Number of Visitors		
• busiest day:	<u>Zero</u>	<u>200</u>
• average/week:	<u>Zero</u>	<u>1000</u>
G. Anticipated Number of Deliveries/Pickups		
• busiest day:	<u>Zero</u>	<u>40 / 50</u>
• average/week:	<u>Zero</u>	<u>150 / 200</u>

V. SUPPLEMENTAL INFORMATION FOR SELECTED USES

A. Commercial Meeting Facilities Food Serving Facilities		
• restaurant/deli seating capacity:	_____	
• bar seating capacity:	_____	
• public meeting room seating capacity:	_____	
• assembly capacity:	_____	
B. Residential Care Facilities (6 or more residents) Day Care Centers	<u>Existing</u>	<u>Proposed</u>
• type of care:	_____	_____
• total number of guests/children:	_____	_____
• total number of bedrooms:	_____	_____
• distance to nearest existing/approved facility/center:	_____	_____

WATER SUPPLY/WASTE DISPOSAL INFORMATION SHEET

I. WATER SUPPLY	<u>Domestic</u>	<u>Emergency</u>
A. Proposed source of Water (eg., spring, well, mutual water company, city, district, etc.):	<u>City</u>	<u>City</u>
B. Name of Proposed Water Supplier (if water company, city, district): annexation needed?	<u>American Canyon</u> Yes ___ No <u>X</u>	<u>American Canyon</u> Yes ___ No <u>X</u>
C. Current Water Use (in gallons/day): Current water source:	<u>Zero</u> <u>None</u>	<u>Zero</u> <u>None</u>
D. Anticipated Future Water Demand (in gallons/day):	<u>42,600</u>	<u>N/A</u>
E. Water Availability (in gallons/minute):	<u>30</u>	<u>5000</u>
F. Capacity of Water Storage System (gallons):	<u>N/A</u>	<u>N/A</u>
G. Nature of Storage Facility (eg., tank, reservoir, swimming pool, etc.):	<u>N/A</u>	<u>N/A</u>
F. Completed Phase I Analysis Sheet (Attached):		
II. LIQUID WASTE	<u>Domestic (sewage)</u>	<u>Other (please specify)</u>
A. Disposal Method (e.g., on-site septic system on-site ponds, community system, district, etc.):	<u>Community System</u>	<u>N/A</u>
B. Name of Disposal Agency (if sewage district, city, community system): annexation needed?	<u>Napa Sanitation District</u> Yes ___ No <u>X</u>	<u>N/A</u> Yes ___ No <u>X</u>
C. Current Waste Flows (peak flow in gallons/day):	<u>Zero</u>	<u>N/A</u>
D. Anticipated Future Waste Flows (peak flows in gallons/day):	<u>9,360 gallons</u>	<u>N/A</u>
E. Future Waste Disposal Capacity (in gallons/day):	<u>N/A</u>	<u>N/A</u>
III. SOLID WASTE DISPOSAL		
A. Operational Wastes (on-site, landfill, garbage co., etc.):	<u>Landfill; Waste diversion</u>	<u>N/A</u>
B. Grading Spoils (on-site, landfill, construction, etc.):	<u>On-site</u>	<u>N/A</u>
IV. HAZARDOUS/TOXIC MATERIALS (Please fill out attached hazardous materials information sheet, attached)		
A. Disposal Method (on-site, landfill, garbage co., waste hauler, etc.):	<u>N/A</u>	<u>N/A</u>
B. Name of Disposal Agency (if landfill, garbage co., private hauler, etc.):	<u>N/A</u>	<u>N/A</u>



FILE # PO9.00330

NAPA COUNTY CONSERVATION, DEVELOPMENT AND PLANNING DEPARTMENT
1195 Third Street, Suite 210 Napa, California 94559
(707) 253-4417

APPLICATION FOR TENTATIVE PARCEL MAP OR TENTATIVE SUBDIVISION MAP

For Office Use Only

GENERAL PLAN/SPECIFIC PLAN DESIGNATION:
LIGHT INDUSTRIAL/ BUSINESS PARK

ZONING DISTRICT IP-2C Date Submitted: 7-21-09

REQUEST DIVIDE EXISTING ~ 34 ACRE Date Complete: _____
PARCEL INTO ELEVEN PARCELS. Date Published: _____
PLEASE ALSO SEE UP FILE ZA CDPC BS Appeal

AT PO9.00329. ALL TIME SHOULD Hearing _____
BE BILLED HERE. Action _____

To Be Completed By Applicant (Please Print or Type)

Applicant's Name: Napa 34 Holdings LLC - Brian Kaufman, Member

Telephone #: (916) 920 - 4900 Fax #: (916) 920 - 8906 E-Mail: bkaufman@wallerkaufmansutter.com

Mailing Address: 2617 Castro St. Sacramento CA 95818
No. Street City State Zip

Status of Applicant's Interest in Property: Member in LLC

Property Owner's Name: Same as above

Telephone #: () - Fax #: () - E-Mail: _____

Mailing Address: _____
No. Street City State Zip

Site Address/Location: (none assigned) Airport Boulevard Napa CA
No. Street City State Zip

Assessor's Parcel #: 057-210-056 Existing Parcel Size: Approx. 34 acres

Purpose for Division: Parcelization for sale of individual future structures.

Vesting Map? YES NO

I certify that the above statements are correct and that the information contained on the accompanying Parcel/Subdivision Map is accurate. I hereby authorize such investigations including access to County Assessor's Records as are deemed necessary by the County Planning Division for preparation of reports related to this application, including the right of access to the property involved.

[Signature] 6/23/09 [Signature] 6/23/09
Signature of Applicant Date Signature of Property Owner Date

Brian Kaufman, Member Brian Kaufman, Member
PRINT NAME PRINT NAME

TO BE COMPLETED BY CONSERVATION DEVELOPMENT AND PLANNING DEPARTMENT

*Application Fee Deposit \$ _____ Receipt No.: _____ Received by: _____ Date: _____

**Total Fees will be based on actual time and materials*

WATER SUPPLY/WASTE DISPOSAL INFORMATION

I.	PROPOSED WATER SUPPLY	<u>Domestic</u>	<u>Emergency</u>
	A. Source of Water (eg. spring, well, mutual water company, city, district, etc):	City _____	City _____
	B. Name of Water Supplier (if water company, city, district Annexation needed?)	<u>American Canyon</u> <input type="checkbox"/> Yes <input checked="" type="checkbox"/> No	<u>American Canyon</u> <input type="checkbox"/> Yes <input checked="" type="checkbox"/> No
	C. Water Availability (in gallons/minute):	32 _____	5,000 _____
	D. Capacity of Water Storage System (in gallons):	N/A _____	N/A _____
	E. Nature of Storage Facility (e.g., tank, reservoir, swimming pool, etc):	N/A _____	N/A _____
II	PROPOSED LIQUID WASTE DISPOSAL	<u>Domestic</u> (sewage)	<u>Other</u> (please specify)
	A. Disposal Method (e.g., on-site septic system, on-site ponds, community system, district, etc.):	<u>Community system</u>	_____
	B. Name of Disposal Agency (if sewage district, city, community system):	<u>Napa Sanitation District</u>	_____
	Annexation needed?	<input type="checkbox"/> Yes <input checked="" type="checkbox"/> No	<input type="checkbox"/> Yes <input type="checkbox"/> No

SITE LOCATION MAP REQUIREMENTS

One (1) copy of a site location map. Said map shall consist of a 7" by 5½" portion of the 7.5 minute U.S. Geological Survey Topographic map that covers the project vicinity or an accurate reproducible copy thereof. This map section shall be pasted or taped (not stapled) in the space provided on the site location map blank contained in this application packet. The following information shall be accurately plotted thereon:

- a) The location of the boundary lines of all existing parcels involved and any new parcels to be formed.
- b) The location of all existing improvements to be used including but not limited to existing access roads.
- c) The location of all new improvements proposed including but not limited to buildings and access roads/driveways. For the purpose of this section proposed building sites on parcel/subdivision maps along with all the associated improvements necessary to put a home at the location selected shall be considered as "new improvements".

The location of all boundary lines and improvements plotted must be accurate to within 50 feet (i.e., 1/20th of an inch)

The symbols to be used in preparing this location map are specified in the legend on the site location map blank provided.

INDEMNIFICATION AGREEMENT

Pursuant to Chapter 1.30 of the Napa County Code, as part of the application for a discretionary land use project approval for the project identified below, Applicant agrees to defend, indemnify, release and hold harmless Napa County, its agents, officers, attorneys, employees, departments, boards and commissions (hereafter collectively "County") from any claim, action or proceeding (hereafter collectively "proceeding") brought against County, the purpose of which is to attack, set aside, void or annul the discretionary project approval of the County, or an action relating to this project required by any such proceeding to be taken to comply with the California Environmental Quality Act by County, or both. This indemnification shall include, but not be limited to damages awarded against the County, if any, and cost of suit, attorneys' fees, and other liabilities and expenses incurred in connection with such proceeding that relate to this discretionary approval or an action related to this project taken to comply with CEQA whether incurred by the Applicant, the County, and/or the parties initiating or bringing such proceeding. Applicant further agrees to indemnify the County for all of County's costs, attorneys' fees, and damages, which the County incurs in enforcing this Indemnification agreement.

Applicant further agrees, as a condition of project approval, to defend, indemnify and hold harmless the County for all costs incurred in additional investigation of or study of, or for supplementing, redrafting, revising, or amending any document (such as an EIR, negative declaration, specific plan, or general plan amendment) if made necessary by said proceeding and if the Applicant desires to pursue securing approvals which are conditioned on the approval of such documents.

In the event any such proceeding is brought, County shall promptly notify the Applicant of the proceeding, and County shall cooperate fully in the defense. If County fails to promptly notify the Applicant of the proceeding, or if County fails to cooperate fully in the defense, the Applicant shall not thereafter be responsible to defend, indemnify, or hold harmless the County. The County shall retain the right to participate in the defense of the proceeding if it bears its own attorneys' fees and costs, and defends the action in good faith. The Applicant shall not be required to pay or perform any settlement unless the settlement is approved by the Applicant.

NAPA 34 Holdings LLC
Applicant

6/23/09
Date



Brian Kaufman, Member

Property Owner (if other than Applicant)

Napa Commerce Center

Project Identification

LAND DIVISION APPLICATION COMPLETENESS CHECKLIST

Pursuant to state law, a determination of completeness will be made within thirty (30) days of application submittal.

1. Completed Signed Land Division Application.
2. Completed Land Division Water Supply/Waste Disposal Information Sheet.
3. Site Location Map (on 7" by 5½" portion of 7.5 minute U.S. Geological Survey Topographic Map).
4. To-Scale Tentative Map (6 copies-parcel map, 12 copies-subdivision) –Sec. 17.08.020, 17.08.030 & 17.08.050(A).
5. 8½" by 11" Blackline Reduction of Tentative Map (If tentative map larger than 8½" by 11").
6. Preliminary Storm Drainage Plan—Sec. 17.08.030(15).
7. Public Facilities Installation/Scheduling Plan—Sec. 17.08.040(2) & (3). See project description and Drainage report
8. Contiguous Ownership Inclusion Statement—Sec. 17.08.040(6) see tentative map notes
9. Title Insurance Co. Certified List of All Property Owners within 300 feet of the Subject Parcel Specifying Name, Address, and Parcel Number –Sec. 17.08.040(9).
10. Assessor's Pages Used in Compiling Adjoining Property Owners List.
11. Pre-Submittal Application Review Meeting with Planning Staff for General Plan and Zoning Consistency Determination. Fee deposit to be determined at the time of the Pre-Application meeting (Date: Jul 16, 2009)
12. Indemnification Agreement – (to be signed and submitted prior to approval)
13. Check Made out to Napa County for: \$ _____ (Fees to be determined at time of submittal)
14. Preliminary Soils Report on Entire Property (4 copies) - Section 17.08.040(8).
15. Detailed Soils Report on Impacted Lots and Common Facilities (4 copies) (if preliminary report shows that critically expansive soils or other soil problems exist) Section 17.42.030.
16. Preliminary Geological Hazards Report on Entire Property (4 copies) Section 17.08.040(8).
17. Detailed Geologic Hazards Report on Impacted Lots and Common Facilities (4 copies) (if preliminary report shows that slope stability, faulting or other geologic problems exist) Section 17.42.030.
18. Deferral (until application for a development permit, lot line adjustment, or other permission) of Requirement for Preliminary Geologic (#15) or Soils Reports (#13) (only acceptable if NO potential land-division-related improvements could be located on geologically sensitive lands).
19. Alquist-Priolo Fault Hazard Study (for any portion of property within Alquist-Priolo Special Studies Zone) –Section 17.08.040(4).
20. Preliminary Biologic Survey Report on Entire Property (2 copies) (if property in environmentally-sensitive area as determined by the Planning Director)—Sec. 17.08.040(12).

-Continued on Next Page-

- 21. Preliminary Archaeological/Historical Survey Report on Entire Property (2 copies) (if property in culturally-sensitive area as determined by the Planning Director)—Sec.17.08.040(13).
- 22. Mobile Home Park Conversion Resident Impact Report— Sec. 17.08.070.
- 23. Environmental Health Dept-Approved Soil Evaluation Report (if on-site septic systems planned) --Sec. 17.08.040(7) OR
- 24. Environmental Health-Dept-Approved Percolation Test (if property further than 1500 feet from nearest public sewer and any proposed parcel smaller than 40 acres (non-prime agricultural soil areas) or 10 acres (prime soil areas) Sec. 17.08.040(7), 17.36.060(C).
- 25. Engineering Feasibility Report (if winery, if on-site pond system or engineered septic systems proposed, or if peak waste flows exceed 1500 gallons/day) – Sec. 17.08.040(7).
- 26. Water Availability Letter from a Qualified Well Driller or Geologist (if "buyer Beware Statement" for water not to appear on final map)—Sec. 17.14.230.
- 27. Water/Sewer Service Availability/Treatment Capacity Non-exceedance Letter(s) (if water company, water district, or sewage disposal agency to be used)—Sec. 17.08.040(7). Letter requested
- 28. Building Conversion Notices (if conversion to condominiums, community apartments, or stock cooperatives involved) Sec. 17.08.040(5).
- 29. Additional Information that may be Required by the Planning Director— Sec 17.08.040(14)
 - Traffic Study
 - Phase 1 Water Supply Study
 - _____
 - _____

Napa Commerce Center

PROJECT DESCRIPTION

Property Ownership

Napa 34 Holdings, LLC
Attn. Mr. Brian Kaufman, Member
2617 Castro Street
Sacramento, CA 95818
(916) 920-4900
bkaufman@wallerkaufmansutter.com

RECEIVED

JUL 21 2009

NAPA CO. CONSERVATION
DEVELOPMENT & PLANNING DEPT.

Property Agents

TLA Engineering & Planning
Brad Shirhall, Director of Planning
1528 Eureka Road, Ste. 100
Roseville, CA 95661
(916) 786-0685
bshirhall@tla-inc.com

RMW Architecture & Interiors
Jeff Leonhardt, Principal
1718 Third Street, Ste 101
Sacramento, CA 95811
(916) 449-1400
jleonhardt@rmw.com

Introduction

This document provides a comprehensive description of the components included in the proposed Napa Commerce Center project. It is a narrative statement regarding relevant aspects of the project, the project site, requested entitlements and the project objectives. A brief discussion of the existing regulatory setting and a justification for approval of the project is also included.

Project Location

The project site is located in Section 2, Township 4 North, Range 4 West, Mount Diablo Base and Meridian, situated at the southwest corner of Airport Boulevard and Highway 29 (see Figure 1). It is a 34± acre parcel that fronts the south side of Airport Boulevard west of Highway 29. It is immediately east of the future Devlin Road and would otherwise be located at the southeast corner of the Devlin Road intersection with Airport Boulevard. The project site comprises Assessor Parcel Number 057-210-056.

Site Description

The project site consists of undeveloped and unimproved grassland, previously used for grazing lands of the historic Gunn-Greenfield Ranch. Elevations on the site range from about 50 feet above mean sea level to about 70 feet. The site's open grasslands support little woody vegetation. Willows and coyote brush

(shrubs) are scattered throughout. Small amounts of wetland vegetation are located within a natural drainage swale that flows east to west across the site.

Airport Boulevard fronts the site to the north. Airport Boulevard is a 4-lane arterial road designed to expedite through traffic and to provide efficient access to the regional highway network. It contains two through lanes of traffic in each direction. It also has a continuous raised median, left-turn pockets at existing intersections, and bicycle/pull-off lanes and sidewalks adjacent to existing development.

Devlin Road is stubbed south from Airport Boulevard at the northwest corner of the project site. Devlin is also stubbed at project site's south boundary where it extends south to Fagan Creek. Devlin Road is a planned, local collector roadway that would ultimately provide a connection between the Soscol Ferry Road under crossing and Green Island Road in the south.

The previously abandoned alignment for Aviation Way is located along the southern boundary of the project site. This is an abandoned road segment that prior to construction of Airport Boulevard, provided linkage between Highway 29 and the Napa County Airport. The roadbed sits within an existing 60 foot wide storm drain, sewer and appurtenances easement. Aviation Way is no longer used or maintained as a public road as it is not a component of the Circulation Plan for the Airport Industrial Area Specific Plan and serves no circulation purpose.

Surrounding uses north of the site include a mix of developed land and former agricultural fields, most of which are no longer farmed. South of the site is undeveloped land and a pond created as wetland mitigation area for other Napa County development projects. East of the project site is Highway 29 and undeveloped agricultural fields.

An unnamed tributary to Sheehy Creek (the above mentioned drainage swale) traverses the project site from the east, flowing across the site from a culvert under Highway 29. It enters the project site approximately midway along the eastern boundary and exits the parcel, similarly traverses the adjacent parcel to the west and exits via a 42 inch concrete culvert under Airport Boulevard. Beyond Airport Boulevard, the water is conveyed in an underground storm drain system to Sheehy Creek. A wetlands delineation (Corps certification November 2008) has been conducted for the project site. The delineation identified 3.19 acres of jurisdictional wetland resources.

A PG&E high pressure gas line and associated 15 foot easement also cuts through the southwest corner of the project site.

An Archeological Resource Survey was performed on the site in 1988 by Archeological Resource Service (updated June 2009 and included with application materials). The current analysis reports as follows:

No prehistoric artifacts or sites were identified and there are no historic properties or potentially significant cultural resources within or adjacent to the project area. Foundations remains of a large agricultural building (built after 1927 and removed from the property sometime after 1983) and a second small outbuilding were identified, but the features are not potentially significant cultural resources.

In conclusion, no listed historic properties or potentially eligible historic properties are located within or adjacent to the subject parcel; therefore the proposed development project will not affect any potentially significant cultural resources or listed historic properties. No specific recommendations are warranted at this time, however, general recommendations have been provided in the event of an unanticipated discovery within the parcel.

Project Objectives

- o Create a mixed-use project that will satisfy identified market-based requirements supporting a myriad of warehouse, distribution, office/administrative and related users taking advantage of local and regional business opportunities while enhancing local support services of the Napa Valley wine industry.
- o Develop a master-planned project that makes efficient albeit environmentally sensitive use of the highway frontage site given the constrained supply of easily accessible, highly visible, well-located, developable industrial land in Napa County.
- o Craft an institutional quality development endowed with high-quality, unique, and attractive architectural style that meets or exceeds Napa County's design expectations.
- o Maximize preservation of existing linear wetland features.
- o Earn commercially reasonable and economically viable financial returns commensurate with the level of investment risk incurred.

Proposed Project

General Use & Design – The project proposes a Tentative Map and Use Permit to create and develop eleven parcels. The natural break on the site occurs at the linear wetland feature, which is proposed for preservation. The break essentially creates two uneven halves. The southern half encompassing approximately 19 acres would be subdivided into four parcels, three of which would encompass a single light industrial/warehouse structure and associated parking spaces. The fourth would encompass a 17,830± square foot area reserved for stormwater detention or retention depending on the recommendations of the final drainage report. The northern half of the site would be subdivided into 6 parcels, five of which would encompass an office structure and associated parking. The sixth would encompass a 12,500± square foot area reserved for stormwater detention or retention depending on the recommendations of the final drainage report. Not every parcel would contain the exact number of parking spaces required under Napa County Code for the associated use, although every attempt has been made ensure near compliant parcels. In light of this a reciprocal parking agreement will be necessary for this project. The linear wetland feature would reside in a separate 2.7± acre eleventh parcel eventually held in common and managed by a property owners association.

PROPOSED USES & SIZE			
Building	Total Size	Use / Sq. ft.	
		Office	Warehouse
A	43,600	43,600	0
B	43,600	43,600	0
C	7,563	7,563	0
D	7,563	7,563	0
E	10,810	10,053	757
F	81,631	10,449	71,182
G	154,864	14,867	139,997
H	148,840	15,033	133,807
Total	498,471	152,728	345,743

*SUPERSEDED...
 SEE PLANS*

Access – Access to the site would be concentrated on Devlin Road. The Airport Industrial Area Specific Plan (AIASP) expresses a preference that access from Devlin Road be limited to curb cuts spaced approximately 200 feet south of the intersection with Airport Boulevard with similar subsequent 200 foot

minimum spacing for additional access points. Full, all direction access to the northern half of the project site is proposed approximately 250 feet south of the intersection of Devlin Road with Airport Boulevard. This access would be directly across Devlin Road from a similar access point eventually used by the recently approved Greenwood Commerce Center. Right-of-way will be dedicated where appropriate.

The AIASP provides advisory language stating “No direct access to local properties should be permitted from Airport Road.” The specific plan language is advisory in that it only specifies a preference for limited access; not a mandate.

When the preference was initially expressed in the then new AIASP for limited or no access on Airport Boulevard there was little regard for, or concern with filling wetlands. Today, filling wetlands on the project site is hugely difficult given permitting agencies’ near moratoria on the activity and the costs associated with mitigation. The effect of this is a project site bisected by a wetland feature. The wetland in conjunction with other code requirements limiting access from Devlin Road to every 200 feet starting at Airport Boulevard unknowingly conspire to allow a single access to a nine acre project site. In response the project proposes a second access to the northern half of the project site with a right-in, right-out driveway on Airport Boulevard approximately 200 feet east of the Devlin Road/Airport Boulevard intersection. The southern half of the project site would be accessed from two driveways proposed on Devlin Road

Parcelization – Parcels are proposed around every structure and its associated parking. Every effort has been made to include sufficient parking with each parcel. Minimum parcel size is 0.69 acres, excluding parcels for detention and water quality.

Site Sculpture and Monument Signage – A significant project sculpture is proposed on the site near the intersection of Highway 12 and Highway 29. The intent of the sculpture is to create a landmark to highlight this gateway into the Napa Airport Industrial Park Zone. The sculpture design would take the form of a 32 foot tall wine glass constructed from shaped 2 inch by 2 inch painted tube steel with curved decorative translucent polycarbonate panels. The primary project monument sign would be integrated into the hardscape and landscaped area that surrounds the sculpture. A secondary monument sign is proposed at the North West Corner of the site at the intersection of Airport Boulevard and Devlin Road. This monument sign location would be enhanced by the addition of a stack of four wine barrels centered in the hardscape area.

Landscaping – The project would be fully landscaped using plants appropriate for the Napa Valley. Low water use plants would be used extensively, while moderate water use plants would be concentrated at accent points, such as driveways, intersections and building entries. The plantings would be automatically irrigated using efficient drip, spray and rotor distribution systems that are appropriate to the size of the planters. The project would make use of recycled water if available.

Buildings – The project plan proposes five office buildings at the northern portion of the site consisting of a pair of two story office buildings and three one story office buildings. These five northern buildings would total 113,136 gross square feet. The project plan also proposes three warehouse buildings at the southern portion of the site totaling 385,335 gross square feet. All eight buildings would be constructed primarily of site cast, tilted concrete panels with a variety of architectural enhancements. The typical wall panels would be enhanced with reveals and a textured elastomeric coating in a multicolored paint pallet. The areas around the building entries would also be enhanced with a mixed combination of stone veneer, metal siding, aluminum accent panels, tinted glazing in aluminum frames, architectural light shelves, painted architectural steel elements and exposed stain grade architectural glu-lam beams supporting standing seam metal roofs. The placement of these enhancements would be focused at the locations most

visible from the public roadways with particular attention being paid to the views along Airport Boulevard and Highway 29.

Sustainable Materials & Construction Practices – The project would incorporate a variety of sustainable materials and construction practices to include the following: pollution prevention, commissioning of the building energy systems, refrigerant management, storage and collection of recyclable materials, use of building materials containing recycled materials, construction waste management, environmental tobacco smoke control, protection of existing natural habitats, storm water quality control, heat reflecting roof membranes, light pollution reduction, water efficient landscaping, recycled water for irrigation, water use reduction methods, low VOC emitting sealants, adhesives, coatings, floorings, and wood materials.

Retaining Walls – Retaining walls would be strategically placed to minimize grading and to maximize wetland protection. Their proposed locations are indicated on the Grading and Utilities Plan. The maximum height would be approximately fifteen feet.

Wetland Impact – Approximately 3.19 acres of wetland are found on the site including wetland swale, seasonal wetland and seep. The project has been designed with the goal of avoiding nearly all of the wetlands. Two wetlands identified as 0.48 acres by Northfork Associates would be filled under permitting with the US Army Corps of Engineers (Corps). The Corps has verified the wetlands on the project site. The linear wetland feature (wetland swale) on site will be left intact. On site wetlands enhancement is being explored as possible mitigation for the 0.48 acres of wetlands fill. Preservation of and/or creation of wetlands on site may require the creation of a conservation easement on site and dedication of that easement to a third party conservatorship.

Storm Water Detention – Two storm water detention basins are proposed, one on each side of the above mentioned linear wetland feature. The northern basin would encompass approximately 12,500 square feet. The southern basin would encompass approximately 18,100 square feet. The detention basins would work in conjunction with on-site water quality BMP devices to mitigate for post construction stormwater quality and for existing downstream drainage structures which have limited capacity to take increases in flow rates. The detention basins would reduce the peak post-development flow rates for the two, ten, and 100-year, 24-hour storms to approximately the pre-development flow rates during the same storm events. They are part of the project's Stormwater Management Plan which will propose to utilize detention and flow-through water quality devices in-lieu of on-site retention.

High Pressure Gas Line – As mentioned in the site description there is an existing sixteen inch high pressure natural gas line crossing the bottom third of the site. The pipe is believed approximately 4 feet below ground surface. The project proponent will seek approval from PG&E to relocate the gas line such that it would not interfere with proposed building placement. The line would be located under parking lot pavement so it could be accessed in the future without hampering structure placement. The gas line would be reconnected before it crosses the wetland area to avoid additional wetland impacts.

Phasing – The current intent of the project proponent is to segregate site development into a north and a south phase. The south development phase would likely occur first. Similarly, recordation of individual parcels would occur in phases and would likely be concurrent with structure and/or site development.

Existing Regulatory Setting

Specific Plan – The project site is located within the Airport Industrial Area Specific Plan and is designated Light Industrial/Business Park by the Specific Plan. This designation is intended to provide

areas exclusively for modern, non-nuisance light industrial and office uses which are compatible both with each other and with adjoining non-industrial areas, including the Napa County Airport, the State Route 29 corridor, and surrounding agricultural and open space areas.

The Specific Plan indicates that this designation is intended to attract development of a higher standard with respect to construction characteristics, on-site amenities, standards of acceptable use, and off-site improvement requirements. It is intended to accommodate light industrial uses such as research and development, light manufacturing, light assembly, warehousing and distribution, large administrative headquarters, and other professional and administrative uses. This designation allows the implementation of special requirements for common improvements, site and building design, landscaping, signage, off-street parking, noise control, and outdoor storage.

Zoning – The project site is zoned IP:AC (Industrial Park with Airport Compatibility Combination District D) under the Napa County Zoning Ordinance. Like the Specific Plan designation, the purpose of the IP zoning district provides areas exclusively for modern, non-nuisance light industrial and office uses which are compatible both with each other and with the adjoining non-industrial areas including the Napa County Airport, the Highway 29 corridor, surrounding agricultural, open space areas, and which have no significant potential for major pollution, adverse visual impacts, or nuisance or hazard factors. Land uses in these areas are subject to special performance standards to ensure harmonious, unified and cohesive development. Vacant parcels are subject to lot size restrictions to ensure that opportunities for large-site business/industrial park developments will not be lost through premature subdivision into small parcels.

The minimum lot size in this district is typically five acres, the Planning Commission, however, may allow parcels to be created that are less than five acres under special circumstances such as when the project is a part of a comprehensive development plan with highly unified site, architectural, landscape and signage design approaches. The maximum floor area ratio for warehousing uses may be as high as 0.50 square feet of floor area per one (1.0) square foot of net lot area.

The landscape setback requirements for the district require a 35 foot minimum/55 foot average landscape corridor from the right-of-way along Airport Boulevard and a 25 foot minimum/40-foot average setback from the right of way along Devlin Road.

Structure design is required to be harmonious with the local setting and with neighboring developments. All facilities must reflect a high standard of architectural design, and be subject to careful architectural review. Buildings are to be either of reinforced concrete and steel, masonry, or wood frame construction. The maximum height of structures is limited to 35 feet.

Warehouse buildings of 10,000 square feet of gross floor area are required to have at least one off-street loading space, plus one additional space for every 40,000 square feet of gross floor area. Off street loading spaces should not be located within the required front yard and shall not be placed to face any public street

The Napa County Code section 18.110.030 requires parking to be provided for warehousing in the amount of 1 space per 1,000 square feet for the first 10,000 square feet of building area and 1 space for every 2,000 square feet thereafter. However, in the Specific Plan area the requirement is increased to require 1 space per 1,000 square feet for the first 20,000 square feet of building area. Parking is required for the associated office space at a rate of 4 spaces for every 1,000 square feet. For the project as proposed, a total of 814 spaces would be required for the cumulative building area. Disaggregated into north and south building sites as bisected by the wetland feature the northern portion requires 450 parking spaces and would provide 455. Similarly, the southern site requires 364 spaces and would provide 353 spaces. Ten additional spaces could be provided for Building F if a future tenant or property owner

requires them. The potential future spaces are indicated on the site plan at the southwest corner of the site plan, grayed out from the remainder of line work. Total parking spaces proposed are 808 with ten extra available if an end user was to deem them necessary.

NORTH PARKING						
Building	Total Size	Use / Sq.ft.		Parking		Deficit/Surplus
		Office	Warehouse	Required	Provided	
A	43,600	43,600	0	174.4	170	-4.4
B	43,600	43,600	0	174.4	170	-4.4
C	7,563	7,563	0	30.252	38	7.748
D	7,563	7,563	0	30.252	36	5.748
E	10,810	10,053	757	40.969	41	0.031
Total				450.273	455	4.727
SOUTH PARKING						
Building	Total Size	Use / Sq.ft.		Parking		Deficit/Surplus
		Office	Warehouse	Required	Provided	
F	81,631	10,449	71,182	87.387	77	-10.387
F	Potential extra spaces				10	10
G	154,864	14,867	139,997	139.4665	139	-0.4665
H	148,840	15,033	133,807	137.0355	137	-0.0355
Total				363.889	363	-0.889
Grand Total				814.162	818	

*SUPERSEDED
 ...SEE PLANS*

As discussed in the Proposed Project section above, the project site contains a wetland swale, a seep and an isolated pool. Approximately 0.48 acres including the wetland seep at the northeast corner and the isolated pool near the southern property line would be impacted as part of the project construction. Consequently, the project would be subject to authorization under Section 404 of the Clean Water Act (CWA) for the discharge of fill material into waters of the United States. As well, Section 1602 of the California Fish and Game Code requires written notification to the California Department of Fish and Game before a stream may be altered. The department has discretion to claim jurisdiction over streambed alteration.

Finally, regarding the requirements specific to Airport Compatibility Combination District D the proposed use, density, and development standards are compatible with District D requirements.

Requested Entitlements

The proposed project requires the following entitlements:

1. Tentative Parcel Map to subdivide a 34± acre parcel into eleven parcels as follows:

PROPOSED PARCEL SIZES		
Parcel	Approx. sq.ft.	Acres*
1 A	149,802	3.44
2 B	111,535	2.56
3 C	30,303	0.70
4 D	29,887	0.69
5 E	40,687	0.93
6 F	217,211	4.99
7 G	289,277	6.64
8 H	313,104	7.19
9 J	17,835	0.41
10 K	12,518	0.29
11 L	194,081	4.46
Total	1,406,240	32.28

*SUPERSEDED...
SEE PLANS*

* Represents net acres after accounting for right of way losses and lot line adjustment

2. Use Permit to allow the development of 385,335± square feet of warehouse/industrial buildings and 113,136 square feet of office space on the subject 34±-acre site (Assessor's Parcel No. 057-210-056). In conjunction with the requested Use Permit the project proposes a variation to development standards in accordance with Section 18.40.250 of the Napa County Zoning Ordinance. Specifically, modification to the driveway restriction on Airport Boulevard is requested wherein the project would gain access directly to Airport Boulevard.

Other Requested Actions:

1. The proponent proposes concurrent review and processing of a grading permit so that immediately upon approval of the environmental document, the grading permit can be issued and mass grading of the site can commence, subject to approval and permits from other regulatory agencies;
2. The proponent requests abandonment of the existing utility easement along the old Aviation Way. In its place, the proponent requests establishment of a fifteen foot wide easement that would sufficiently accommodate the existing overhead utility line along the south property line;
3. The project, as currently proposed will require preparation, processing and recordation of a Lot Line Adjustment (LLA) between APN: 057-210-56 and 55. The LLA is intended to occur subsequent to entitlement approval but prior to recordation of the project's final map. This will allow implementation of dedication of the right away for Devlin Road;
4. The proponent requests a waiver to the recent stormwater retention requirements and is proposing on-site detention and water quality best management practices to mitigate increases in storm water flow rates and water quality degradation. A formal waiver request is included with the entitlement application.

Justification for Approval

Land Use

The project has been designed for consistency with the Napa County General Plan, the Napa County Airport Industrial Area Specific Plan and the Napa County Code. One intent of the Specific Plan is to provide adequate areas and standards for the orderly development of viable Business/Industrial Park uses.

The Specific Plan is intended to provide the Napa County Planning Commission, Airport Land Use Commission, and Board of Supervisors with a policy base for decision making with respect to

development within the planning area. The Specific Plan states that “the plan’s policies should not be viewed as unalterable” but rather, as statements of what is considered to be in the best interest of the County at the point in time it was adopted.

Further, the Economic Development Element of the updated General Plan recognizes the limited availability of non-agricultural land in Napa County. As such, Policy E-8(f) states that new industrial uses should make efficient use of the limited supply of industrial land in the county. This project is designed consistent with this policy. Warehouse and industrial-type developments typically realize 35 percent site coverage. The project achieves 35 percent building coverage on the site assuming ultimate net parcel size and inclusive of the preserved wetlands area.

Relief from Development Standard

This project seeks a right-in/right-out driveway entrance on Airport Boulevard contrary to advisory language in the Specific Plan. The basis for the request is as follows:

The property is bisected generally through the center, running east to west by a linear wetland feature. This wetland feature restricts the property owner’s ability to access the northern project site with any more than one access point on Devlin Road. The wetland isolates the northern and southern portions of the project site. There is significant disincentive to fill or cross the wetland feature wholly or in part because of the substantial costs in infrastructure, the significant monetary and time cost involved in federal and state permitting, and ultimately the excessive costs associated with mitigation in Napa County. Access to Devlin Road is restricted to once every 200 feet starting south of Airport Boulevard. The effect of the associated costs to fill or bridge the wetland, and access limitations from Devlin Road is that a project site capable of supporting 113,000± square feet will have access at only one location.

Relief from this standard would have no demonstrable deleterious effect upon the health, safety, and/or welfare of the people and or county of Napa. In fact, strict application of the driveway restriction at this particular project site and location might by itself adversely affect public health, safety and welfare of the people and county of Napa in that a single access point could limit the ability of Napa County emergency services to access the site, and could limit the ability of the public to escape the site in time of need.

END



TRENT CAVE, R.E.H.S.
Director

**NAPA COUNTY DEPARTMENT OF
ENVIRONMENTAL MANAGEMENT**

1185 THIRD STREET, SUITE 101
NAPA, CALIFORNIA 94559-1082
(707) 253-4471 • FAX (707) 253-4443

**DEPARTMENT OF ENVIRONMENTAL MANAGEMENT
PLANNING APPLICATIONS - SUPPLEMENTAL INFORMATION SHEET**

Solid Waste Disposal:

Identify the use and feasibility of the following items:

1. Source reduction of solid waste (any action that causes a net reduction in the generation of solid waste, such as using recyclable materials).
2. Recycling and composting to reduce the solid waste stream (such as collecting, sorting, cleansing, treating and reconstituting materials that would otherwise become solid waste).
3. Transformation and disposal of solid wastes (such as incineration or biological conversions other than composting).
4. Designated wastes/special disposal problems.

See narrative attached.

Hazardous Materials:

Be sure to fill out the Napa County CUPA related Business Activities Form included in your Use Permit package. This information will be used to determine what conditions, if any, will be placed on the use permit application.

All facilities that handle a hazardous material, acutely hazardous material or hazardous waste in quantities exceeding statutory reporting requirements must develop and implement a Hazardous Materials Business Plan within 60 days of commencing use. Facilities that typically store or handle hazardous materials below threshold quantities must submit a Negative Declaration Response to the Hazardous Materials Section. This also must be submitted within 60 days of commencing use.

Additional information on these requirements can be obtained from the Hazardous Materials team in the Department of Environmental Management by calling (707) 253-4471.



Napa County Department of Environmental Management CUPA-Related Business Activities Form

Business Name: Napa Commerce Center

Business Address: _____

Contact: Brian Kaufman

Phone #: 916-920-4900

A. HAZARDOUS MATERIALS

Have on site (for any purpose) hazardous materials at or above 55 gallons for liquids, 500 pounds for solids, or 200 cubic feet for compressed gases (include liquids in AST's and UST's or handle radiological materials in quantities for which an emergency plan is required pursuant to 10 CFR Parts 30, 40 or 70?

YES NO

B. UNDERGROUND STORAGE TANKS (UST's)

1. Own or operate underground storage tanks?

YES NO

2. Intend to upgrade existing or install new UST's?

YES NO

C. ABOVE GROUND STORAGE TANKS (AST's)

Own or operate AST's above these thresholds:

- Any tank capacity with a capacity greater than 660 gallons, or
- The total capacity for the facility is greater than 1,320 gallons?

YES NO

D. HAZARDOUS WASTE

1. Generate hazardous waste?

YES NO

2. Recycle more than 220 lbs/month of excluded or exempted recyclable materials (per H&SC §25143.2)?

YES NO

3. Treat hazardous waste on site?

YES NO

4. Treatment subject to financial assurance requirements (for Permit by Rule and Conditional Authorization)?

YES NO

5. Consolidate hazardous waste generated at a remote site?

YES NO

E. OTHER

1. Does the business activity include car/fleet washing, mobile detailing, auto-body related activities?

YES NO

2. Does the business handle Extremely Hazardous Substances in amounts that would qualify for the Risk Management Program? Some examples and their thresholds common to Napa County include: Ammonia - 500 lbs, Sulfur Dioxide - 500 lbs, Chlorine - 500 lbs.

YES NO



NAPA COUNTY

DEPARTMENT OF PUBLIC WORKS

1195 THIRD STREET • ROOM 201 • NAPA, CALIFORNIA 94559-3092
PHONE 707-253-4351 • FAX 707-253-4627
www.co.napa.ca.us/PublicWorks/Default.htm

ROBERT J. PETERSON
Director of Public Works
County Surveyor-County Engineer
Road Commissioner

WATER AVAILABILITY ANALYSIS

PHASE 1 STUDY

Introduction: As an applicant for a permit with Napa County, it has been determined that Chapter 13.15 of the Napa County Code is applicable to approval of your permit. One step of the permit process is to adequately evaluate the amount of water your project will use and the potential impact your application might have on the static groundwater levels within your neighborhood. The public works department requires that a Phase 1 Water Availability Analysis (WAA) be included with your application. The purpose of this form is to assist you in the preparation of this analysis. You may present the analysis in an alternative form so long as it substantially includes the information required below. Please include any calculations you may have to support your estimates.

The reason for the WAA is for you, the applicant, to inform us, to the best of your ability, what changes in water use will occur on your property as a result of an approval of your permit application. By examining the attached guidelines and filling in the blanks, you will provide the information we require to evaluate potential impacts to static water levels of neighboring wells.

Step #1:

Provide a map and site plan of your parcel(s). The map should be an 8-1/2"x11" reproduction of a USGS quad sheet (1:24,000 scale) with your parcel outlined on the map. Include on the map the nearest neighboring well. The site plan should be an 8-1/2"x11" site plan of your parcel(s) with the locations of all structures, gardens, vineyards, etc in which well water will be used. If more than one water source is available, indicate the interconnecting piping from the subject well to the areas of use. Attach these two sheets to your application. If multiple parcels are involved, clearly show the parcels from which the fair share calculation will be based and properly identify the assessors parcel numbers for these parcels. Identify all existing or proposed wells.

Step #2: Determine total parcel acreage and water allotment factor. If your project spans multiple parcels, please fill a separate form for each parcel.

Determine the allowable water allotment for your parcels:

Parcel Location Factors

The allowable allotment of water is based on the location of your parcel.

There are 3 different location classifications. Valley floor areas include all locations that are within the Napa Valley, Pope Valley and Carneros Region, except for areas specified as groundwater deficient areas. Groundwater deficient areas are areas that have been determined by the public works department as having a history of problems with groundwater. All other areas are classified as Mountain Areas. Please circle your location classification below (Public Works can assist you in determining your classification if necessary):

Valley Floor 1.0 acre feet per acre per year
 Mountain Areas 0.5 acre feet per acre per year
 MST Groundwater Deficient Area 0.3 acre feet per acre per year

Assessors Number(s)	Parcel	Parcel Size (A)	Parcel Factor (B)	Location	Allowable Water Allotment (A) X (B)
057-210-056		34 acres	1.0		34

Step #3:

Using the guidelines in Attachment A, tabulate the existing and projected future water usage on the parcel(s) in acre-feet per year (af/yr). Transfer the information from the guidelines to the table below.

EXISTING USE:

Residential _____ af/yr
 Farm Labor Dwelling _____ af/yr
 Winery _____ af/yr
 Commercial _____ af/yr
 Vineyard* _____ af/yr
 Other Agriculture _____ af/yr
 Landscaping _____ af/yr
 Other Usage (List Separately):
 Vacant _____ af/yr
 _____ af/yr
 _____ af/yr

PROPOSED USE:

Residential _____ af/yr
 Farm Labor Dwelling _____ af/yr
 Winery _____ af/yr
 Commercial _____ af/yr
 Vineyard* _____ af/yr
 Other Agriculture _____ af/yr
 Landscaping _____ af/yr
 Other Usage (List Separately):
 Warehouse & Office 8.8 af/yr
 _____ af/yr
 _____ af/yr

TOTAL: zero af/yr

TOTAL: 8.8 af/yr

TOTAL: zero gallons^{**}

TOTAL: 2,867,293 gallons^{**}

*Water use for vineyards should be no lower than 0.2 AF—unless irrigation records are available that show otherwise.

**To determine your existing and proposed total water use in gallons, multiply the totals (in acre- feet) by 325,821 gal/AF.

Is the proposed use less than the existing usage () Yes (x) No () Equal

Step #4:

Provide any other information that may be significant to this analysis. For example, any calculations supporting your estimates, well test information including draw down over time, historical water data, visual observations of water levels, well drilling information, changes in neighboring land uses, the usage of other water sources such as city water or reservoirs, the timing of the development, etc. Use additional sheets if necessary.

Approximately 560 office employees and 64 warehouse employees.

Conclusion: Congratulations! Just sign the form and you are done! Public works staff will now compare your projected future water usage with a threshold of use as determined for your parcel(s) size, location, topography, rainfall, soil types, historical water data for your area, and other hydrogeologic information. They will use the above information to evaluate if your proposed project will have a detrimental effect on groundwater levels and/or neighboring well levels. Should that evaluation result in a determination that your project may adversely impact neighboring water levels, a phase two water analysis may be required. You will be advised of such a decision.

Signature: _____

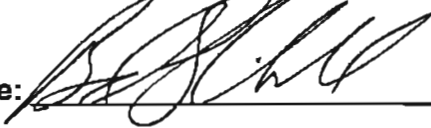

Date: _____

6/19/09

Phone: _____

916-786-0685

Attachment A: Estimated Water Use Guidelines

Typical Water Use Guidelines:

Primary Residence	0.5 to 0.75 acre-feet per year (includes some landscaping)
Secondary Residence	0.20 to 0.30 acre-feet per year
Farm Labor Dwelling	0.06 to 0.10 acre-feet per person per year

Non-Residential Guidelines:

Agricultural:

Vineyards	
Irrigation only	0.2 to 0.5 acre-feet per acre per year
Heat Protection	0.25 acre feet per acre per year
Frost Protection	0.25 acre feet per acre per year
Farm Labor Dwelling	0.06 to 0.10 acre-feet per person per year
Irrigated Pasture	4.0 acre-feet per acre per year
Orchards	4.0 acre-feet per acre per year
Livestock (sheep or cows)	0.01 acre-feet per acre per year

Winery:

Process Water	2.15 acre-feet per 100,000 gal. of wine
Domestic and Landscaping	0.50 acre-feet per 100,000 gal. of wine

Industrial:

Food Processing	31.0 acre-feet per employee per year
Printing/Publishing	0.60 acre-feet per employee per year

Commercial:

Office Space	0.01 acre-feet per employee per year
Warehouse	0.05 acre-feet per employee per year



Department of Environmental Management

MEMORANDUM

DATE: January 5, 2005
TO: All interested parties
FROM: Department of Environmental Management
SUBJECT: Use Permits and Regulated Water Systems

The purpose of this memo is to provide information regarding the current requirements for regulated water system permitting. The Department of Environmental Management has a contract with the State to administer the small water system program. County Code Chapter 13.08 addresses the requirements for local public water systems and includes the definition of a "public water system". This definition states that a public water system is one that is required to be permitted or approved by the Department of Health Services (DHS) Office of Drinking Water or the environmental management director pursuant to the California Safe Drinking Water Act and related laws (which contain selected portions of the Health and Safety Code, Water Code, Business and Professions Code and the California Code of Regulations, Titles 17 and 22). The State regulates the large public water systems and as stated above, this department regulates the small water systems.

The most common new small water system is that serving a winery. During the use permit process, this department reviews the numbers of anticipated visitors and employees and makes a determination if the proposed winery will meet the threshold for a regulated water system. In general, we are looking for either (1) a combined number of peak users (visitors and employees) greater than 25 on a daily basis or (2) the total number of employees equal to or greater than 25. If either of these thresholds is met, the water system will be regulated. If you have questions on whether your proposed project will be regulated as a small water system, you may contact this department as discuss this with the district inspector. If you do not meet these thresholds, but will have a regulated kitchen used for food service for marketing events, you will be regulated as a different type of water system. You will need to submit bacteriological quality sample results from your source(s) with your use permit application, but not the full feasibility report as discussed below.

If your project will be regulated as a small water system, a water system feasibility report will be required as a completeness item at the time of a Use Permit application. This report will ensure that the proposed project can satisfy the technical, managerial and financial requirements of this department and DHS and must include the information listed on the attached worksheet. There is a good chance that existing wells will not meet the construction requirements for a regulated water system. As such, a new supply will have to be developed. If this is the case, the information provided in the feasibility report must reflect this fact. Prior to issuance of a building permit the new water supply must be developed and full plans for the water system must be submitted to and approved by this department.

New Community and Non-Community Water Systems
Technical, Managerial and Financial Capacity Worksheet
(Use Permit Applications and Water System Feasibility Reports)

1. **Water system name**
2. **Name of person who prepared the report**
3. **Technical Capacity:**
 - 1 System description—from source to point of use—what is expected (including treatment, etc).
 - 1 One year projection for water demand and an analysis of the water system to meet the projected demand (project expansion and improvements for a ten year period).
 - 1 Source adequacy:
 - Groundwater: Does the well have a 50-foot seal with a 3-inch annular space? Is a well log available?
 - Surface water treatment: Can the water system comply with the Surface Water Treatment Rule?
 - 1 Water supply capacity. Can the water system (including all sources and storage facilities) supply a minimum of three gallons per minute for at least 24 hours for each service connection served?
 - 1 Provide a characterization of the water quality (or expected water quality if a new source is required), including a comparison with established or proposed drinking water standards and the feasibility of meeting these standards.
 - 1 An evaluation of the feasibility of consolidation with other (existing) water systems.
4. **Managerial:**
 - 1 Description of the organization's ability to manage a water system (personnel to be hired and/or job descriptions for water system maintenance responsibilities). For systems that use land that is not owned by the water system, the terms for a long-term agreement for use of the land/facilities must be disclosed.
 - 1 Document the system's water rights.
5. **Financial:**
 - 1 Budget projection and description of system's financial capacity (your ability to financially support the operation of a water system).

Questions on this worksheet or the information required should be addressed to the water specialist in the Department of Environmental Management.

TRAFFIC INFORMATION

Project Trip Generation							
	Personnel / Visitors				Vehicle Trips		
	Operations	Marketing Events		Operations	Marketing Events		
	Daily M - F	Minimum	Maximum	Daily M - F	Minimum	Maximum	
		Weekends			Weekends		
Operating Hours							
Employees				Employee Trips			
Full-Time				Full-Time			
Seasonal Peak				Seasonal Peak			
Peak Hours				Peak Hours			
Total Employees				Total Employee Trips			
Event Support Staff				Event Support Staff			
Full-Time				Full-Time			
Seasonal Peak				Seasonal Peak			
Total Support Staff				Total Support Staff Trips			
Visitors				Visitor Trips			
Peak Hours				Peak Hours			
Total Visitors				Total Visitor Trips			
				Total Trucks - Deliveries, Shipping, etc. Trips			
Grand Total							
Provide supporting documentation for trip generation rates Submit separate spreadsheets for existing & proposed operations, include a trip generation grand total.				See attached trip generation data sheet.			

PLEASE
SEE
NEXT
PAGE

	Number of People Onsite				
	Seasonal		Marketing Events	Marketing Events	Marketing Events
	Full-Time	Peak			
No. Employees	624				
Support Staff, caterers, clean-up, etc.					
Visitors					
Residents					
Grand Total	624				

APPS-Traffic Information

TRAFFIC INFORMATION FOR CALTRANS REVIEW

Application should include:

Project Location

- Site Plan showing all driveway location(s)
- Show detail of Caltrans right-of-way
- Aerial photo at a readable scale

Trip Generation Estimate

- Spreadsheet for winery applications
 - Provide separate spreadsheets for existing and proposed operations

Caltrans Information Sources

- Traffic Impact Study Guide
- 2001 Traffic Volumes on California State Highways
- Highway Design Manual
- Traffic manual

NAPA COUNTY WINERY TRAFFIC GENERATION CHARACTERISTICS

EMPLOYEES:

Half-hour lunch: All - 2 trips/day (1 during weekday PM peak)

Hour lunch: Permanent Full-Time - 3.2 trips/day (1 during weekday PM peak)

Permanent Part-Time - 2 trips/day (1 during weekday PM peak)

Seasonal: 2 trips/day (0 during weekday PM peak)—crush
see full time above—bottling

Auto Occupancy: 1.05 employees/auto

VISITORS:

Auto occupancy: Weekday - 2.6 visitors/auto

Weekend - 2.8 visitors/auto

Peaking Factors:

Peak Month: 1.65 x average month

Average Weekend: 0.22 x average month

Average Saturday: 0.53 x average weekend

Peak Saturday: 1.65 x average Saturday

Average Sunday: 0.8 x average Saturday

Peak Sunday: 2.0 x average Sunday

Peak Weekend Hour: Winery (3-4 PM) - 0.57 x total for weekend day involved

Average 5-Day Week (Monday-Friday) - 1.3 x average weekend

Average Weekday: 0.2 x average 5-day week

Peak Weekday Hour: Winery (3-4 PM) - 0.57 x total for weekday involved

Roadway PM Peak(4-5 PM?) - 0.38 x total for weekday involved

SERVICE VEHICLES:

Grapes (36 days (6weeks)/season): 1.52 trips/1000 gals/season (4 ton loads assumed)

Materials/Supplies (250 days/yr): 1.47 trips/1000 gals/yr

Case Goods (250 days/yr): 0.8 trips/1000 gal/yr

APPS-Traffic info/char

Napa Commerce Center - Trip Generation - June 2009

Office*	sqft (X 1000)	AM Trips	Enter	Exit	PM Trips	Enter	Exit	Weekday
A	41.706	65.06136	57.254	7.807363	62.14194	10.56413	51.57781	459.1831
B	41.706	65.06136	57.254	7.807363	62.14194	10.56413	51.57781	459.1831
C	7.563	11.79828	10.38249	1.415794	11.26887	1.915708	9.353162	83.26863
D	7.563	11.79828	10.38249	1.415794	11.26887	1.915708	9.353162	83.26863
E	8.85	13.806	12.14928	1.65672	13.1865	2.241705	10.9448	97.4385
Total	107.39	167.5253	147.4222	20.10303	160.0081	27.20138	132.8067	1182.342
Warehouse*	sqft (X 1000)	AM Trips	Enter	Exit	PM Trips	Enter	Exit	Weekday
F	81.631	36.73395	30.12184	6.612111	41.63181	9.991634	31.64018	404.8898
G	152.644	68.6898	56.32564	12.36416	77.84844	18.68363	59.16481	757.1142
H	148.84	66.978	54.92196	12.05604	75.9084	18.21802	57.69038	738.2464
Total	383.12	172.4018	141.3694	31.03232	195.3887	46.89328	148.4954	1900.25
Grand Total		339.927	288.7917	51.13535	355.3968	74.09466	281.3021	3082.592

*ITE Trip Generation (6th Edition) - TLA Engineering & Planning

INDEMNIFICATION AGREEMENT

Pursuant to Chapter 1.30 of the Napa County Code, as part of the application for a discretionary land use project approval for the project identified below, Applicant agrees to defend, indemnify, release and hold harmless Napa County, its agents, officers, attorneys, employees, departments, boards and commissions (hereafter collectively "County") from any claim, action or proceeding (hereafter collectively "proceeding") brought against County, the purpose of which is to attack, set aside, void or annul the discretionary project approval of the County, or an action relating to this project required by any such proceeding to be taken to comply with the California Environmental Quality Act by County, or both. This indemnification shall include, but not be limited to damages awarded against the County, if any, and cost of suit, attorneys' fees, and other liabilities and expenses incurred in connection with such proceeding that relate to this discretionary approval or an action related to this project taken to comply with CEQA whether incurred by the Applicant, the County, and/or the parties initiating or bringing such proceeding. Applicant further agrees to indemnify the County for all of County's costs, attorneys' fees, and damages, which the County incurs in enforcing this indemnification agreement.

Applicant further agrees, as a condition of project approval, to defend, indemnify and hold harmless the County for all costs incurred in additional investigation of or study of, or for supplementing, redrafting, revising, or amending any document (such as an EIR, negative declaration, specific plan, or general plan amendment) if made necessary by said proceeding and if the Applicant desires to pursue securing approvals which are conditioned on the approval of such documents.

In the event any such proceeding is brought, County shall promptly notify the Applicant of the proceeding, and County shall cooperate fully in the defense. If County fails to promptly notify the Applicant of the proceeding, or if County fails to cooperate fully in the defense, the Applicant shall not thereafter be responsible to defend, indemnify, or hold harmless the County. The County shall retain the right to participate in the defense of the proceeding if it bears its own attorneys' fees and costs, and defends the action in good faith. The Applicant shall not be required to pay or perform any settlement unless the settlement is approved by the Applicant.

NAPA 34 Holdings LLC
Applicant

6/23/09
Date

Property Owner (if other than Applicant)

Napa Commerce Center
Project Identification

A NEW REQUIREMENT FOR ALL DEVELOPERS AND LANDSCAPE CONTRACTORS FROM THE COUNTY AGRICULTURAL COMMISSIONER

Please notify our office of all impending deliveries of live plants with points of origin outside Napa County.

Napa County needs your help in preventing the introduction of the Glassy-Winged Sharpshooter (GWSS) into our area. The magnitude of the threat that this half-inch long leafhopper insect poses to our local economy, the environment and our quality of life cannot be overstated.

GWSS feeds off a wide variety of plants and possesses the capability of transmitting a bacterium that causes Pierce's Disease (PD). Grapevines are highly susceptible to a particular strain of this bacterium, which chokes off the water and nutrient flow and eventually kills the plant. GWSS is a stronger flier and a more voracious eater than the common native vectors of PD, and it can quickly spread to all types of habitats in a given location. Ornamental plants and native vegetation may not show any symptoms, but they can serve as reservoirs of PD for many years. GWSS picks up the disease from these infected plants and transmits it to the vineyards while feeding on the grapevines. No other county has as much at risk economically from the threat of PD spread by GWSS.

To combat this threat, Napa County has gone beyond the standard state quarantine regulations in implementing the most rigorous inspection program of any county in the state for incoming plant shipments. *We are asking for your cooperation to purchase plant materials locally when possible and notify our office of all impending deliveries of live plants with points of origin outside Napa County.* An evaluation based on the origin and contents of each shipment will then be made, and, if necessary, trained personnel will be promptly dispatched to perform an inspection upon its arrival at your destination site. When you purchase ornamental plants from local nurseries, the special restrictions imposed by this county program would not apply.

In conjunction with these plant inspections, the Napa County Agricultural Commissioner's Office has developed an extensive year 'round pest detection program aimed at discovering any possible existing GWSS infestations. Thousands of traps have been set up throughout the county and are routinely monitored by staff members and with the help of vineyards personnel. Sweep surveys are conducted at developments which have been landscaped within the last few years as well as at other high-risk locations. We also participate in meetings, discussions and the distribution of informational materials to educate the public and members of the industry about this matter. Please look over the attached brochures, share them with your employees and contact us if you have any training needs, questions or concerns. Our goal is to have everyone in the community aware and helping us look for GWSS!

Thank you for your continued assistance in providing a greater level of protection to safeguard our community from this serious menace.

Sincerely,

David R. Whitmer
Napa County Agricultural Commissioner



Dedicated to Preserving the Napa River for Generations to Come

935 HARTLE COURT
P.O. BOX 2480
NAPA, CALIFORNIA 94558-0522
TELEPHONE (707) 258-6000
FAX (707) 258-6048

June 2, 2009

Conservation, Development and Planning Department
County of Napa
1195 Third Street, Room 210
Napa, CA 94559

RECEIVED

JUL 21 2009

NAPA CO. CONSERVATION
DEVELOPMENT & PLANNING DEPT
COPY

Re: APN 57-210-056

To Whom it May Concern:

The Napa Sanitation District has received a request to provide a "Will Serve" letter for eight proposed buildings to be constructed on the aforementioned parcel. The development will consist of 385,100 square feet of warehouse space and 112,100 square feet of associated office space. The District has been informed that the proposed development will generate approximately 9,360 gallons of wastewater per day which is equivalent to 45 single-family dwellings.

This property is currently within the District's Sphere of Influence but not within the District's boundaries. The District would be able to provide sanitary sewer service to this parcel upon completion of annexation proceedings. The owner/developer will be required to install the sanitary sewer and reclaimed water improvements as specified in the District's Conditions of Approval for the project. Additionally, the owner will be required to pay the appropriate connection and inspection fees, and shall be subject to all applicable rules and regulations of the District.

It should be noted that this area is within the District's Reclaimed Water Benefit Zone. The development will be required to install the necessary facilities to utilize reclaimed water for landscape irrigation.

This "Will Serve" letter is valid for a period of five years from the date of this letter. If the proposed development has not obtained its required Connection Permits from the District at the end of this time, this "Will Serve" letter shall become void.

If you have any questions regarding this matter, please feel free to contact me.

Sincerely,

Timothy B. Healy, P.E.
Assistant General Manager/District Engineer

A handwritten signature in black ink that reads "Robin Gamble Holley".

by: Robin Gamble Holley
Junior Engineer

Cc: Patrick Longtin

09-greenwood2

SUPPLEMENTAL PROJECT
INFORMATION SHEET
(IP Zoning District)

Napa Commerce Center

(Permit/Subdivision # _____)

I. SITE

- A. Size of Parcel (in square feet): 1,481,040 +/- s.f.
- B. Type of Fronting Street (state highway, arterial/
collector/minor roadway): Airport Blvd., 4-lane arterial/collector
Proposed Devlin Rd. - 2-lane collector

II. BUILDING

- A. Size of Building Footprint (in square feet): Total = 448797 +/- S.F. See site plan for break down by building.
- B. Total Building Floor Area (in square feet): Total = 490,503 +/- S.F. See site plan for break down by building.
- C. Warehouse/Storage Space Proposed (in square feet): 346,427 +/- s.f.
- D. Office Space Proposed (in square feet): 144,076 +/- s.f.
- E. Remaining Building Space (in square feet): - 0 -

III. SETBACKS

- A. On-site Developable Area (in square feet): 1,406,575 +/- S.F.
- B. Land Area Between Ultimate Curb Line & Minimum Building Setback Line (in square feet): 62,400 +/- S.F.

IV. OPERATIONS

	<u>Present</u>	<u>Proposed</u>
A. Anticipated Peak Number of Workers/Shift		
● daytime shift:	0	624
● swing shift:	0	0
● graveyard shift:	0	0
B. Current Number of Company Vehicles Principally-Based On-Site:	0	TBD

V. PARKING

	<u>Present</u>	<u>Proposed</u>
A. Number of Parking Spaces		
● single-loaded stalls:	0	709
● double-loaded stalls:	0	72
● total:	0	781

VI. LANDSCAPING

- A. Size of Landscaped Area On-site (in square feet): 320,000 +/- s.f.
- B. Land Area Between Ultimate Curb Line & Minimum Building Setback Line Mounded & Planted In Lawn (in square feet): 68,000 +/- S.F.
(Including undisturbed wetland area)
- C. Number of Trees Adjacent/Within Parking Area adjacent to single-loaded stalls: Graded as swales and mounds. See LS Plans
between double-loaded stalls: See Landscape Plans

VII. STREETS

- | | <u>Current</u> | <u>Ultimate</u> |
|--|---|--------------------------------------|
| A. Right-A-Way Width(s) of Fronting Street(s) (in feet): | <u>Airport Blvd.-106'</u>
<u>Devlin Rd - N/A</u> | <u>Same</u>
<u>Devlin Rd.-68'</u> |

VIII. STORM DRAINAGE

- | | <u>Current</u> | <u>Ultimate</u> |
|--|---------------------------|---|
| A. Right-A-Way Width(s) of Fronting Storm Drainage Channel(s) (in feet): | <u>Airport Blvd.-106'</u> | <u>Same</u>
<u>Devlin Rd.-68'</u> |
| B. Percentage Increase in Flows Calculated at Point In Drainage Channel Immediately Below Point at Which Drainage From Project Site Enters Channel | | <u>+/- 1%, On-Site Detention Provided</u> |
| ● during 10 year storm: | | |
| ● during 100 year storm: | | <u>+/- 1%, On-Site Detention Provided</u> |

IX. UTILITIES

- A. Uncommitted Remaining Capacity of Water Treatment/Delivery System To Be Employed (in gallons/day): Avg day demand =9,330 gpd, irrigation not included.
- B. Uncommitted Remaining Capacity of Sewage Collection/Treatment/Disposal System To Be Employed (in gallons/day): Avg day demand =9,330 gpd

X. SPECIAL UTILITY SERVICE CENTERS

- A. Noise Wall Height (in feet): None
- B. Noise Wall Materials: N/A

XI. NUISANCES

- A. Describe Operations Creating
 - vibration, heat or glare: None
 - smoke, dust, fumes or other contaminants: None
 - odors: None
 - annoying noises: Heavy truck delivery traffic
 - dangerous levels of radioactivity: None
 - electrical disturbances or electromagnetic interference: None

ZONING COMPLIANCE FORM
(IP Zoning District)

X

(Permit _____)

ITEM	PROPOSAL	COMPLIANCE	
		YES	NO
1. Use (page 2- Sec 12278.1) +	Warehouse/Industrial/Office	X	
2. Lot Design (page 5- Sec 12278.3)			
a. Size (5 acres minimum normally; with comprehensive development plan 20,000 ft ²)	Min. 26,136 +/- S.F. Max. 312,760 +/- S.F.	X	
b. Buildable Area (7,000 ft ² minimum)	Min. 18,740 +/- s.f.	X	
c. Width (125 ft minimum)	Min. 234 +/- ft	X	
3. Bldg Design (page 6- Secs 12278.3(c) & .4)			
a. Site Coverage (35%/50%-warehouses maximum)+ *	35.1%	X	
b. Floor/Area Ratio (.35/.50-warehouses)+	38.5%	X	
c. Height (35 ft maximum)+	33'-8" on office. 37'4" for Towers on warehouse	X	
d. Materials (pre-fabricated Tilt up concrete w/veals, textured paint, stone and metal prohibited)+ metal veneer, metal roofs at building entries.		X	
e. Surface Treatment (non-reflective paint required)	Eggshell finish, no glossy paints.	X	
f. Roof Top Equipment (screening required)+	RT Equip to be screened by parapet wall	X	
g. Noise Reduction Measures (_____) + *	Screening of loading docks	X	
4. Building Setbacks (page 7 - Sec 12278.5)			
a. Front**		X	
(1) avg (_____) Airport 35 min 55 avg Devlin 25 min 40 avg SR 29 45 min 55 avg	Min. Avg. Airport 106' 115' Devlin 79' 99' SR 29 61' 71'		
(2) minimum _____		X	
b. Left Side (10' ft minimum)+	10' Min.	X	
c. Right Side (10' ft minimum)+	10' Min.	X	
d. Rear (10' ft minimum)+	10' Min.	X	

- + Standard Not Normally Applicable To Land Divisions
- * Standard Not Applicable To Conforming Uses Legally Established Prior to May 1987
- ** Front Setback and Landscaping Requirements Apply To Any Side of a Lot That Adjoins A Public Street or Highway
- *** Alternate Standard Applicable To Conforming Uses Legally Established Prior to May 1987 (Sec 12278.2(b))

ITEM	PROPOSAL	COMPLIANCE	
		YES	NO
5. Site Layout (page 9- Sec 12278.6(a))			
a. Co-ordinated Site Design (required)		X	
b. Fences, Curbs or Walls Between Parcels with Similar Uses (prohibited)+	None proposed	X	
c. Clear Road/Railroad Sight Lines (maintenance required)	N/A		
d. Optimum Solar Access (to be provided)	N/A		
e. Convenient Pedestrian Path System (required)+	See Site Plan	X	
f. Convenient Secure Bicycle Parking Areas (required)+	Per Code	X	
6. Taxiway Access (page 9- Sec 12278.6(d))			
a. FAA Regulation Compliance (required)*	N/A		
b. Taxiway Easement Width (93 ft minimum)*	N/A		
c. Street Crossings (prohibited)*	N/A		
d. Signal & Gate Installation (required at rail crossings)*	N/A		
7. Railroad Access (page 10- Sec 12278.6(e))			
a. Existing (maintenance required)*	N/A		
b. Easement Width (20 ft with 300 foot turning radii)*	N/A		
c. New Arterial or Collector Street Crossings (prohibited) *	N/A		
8. Driveways (page 9- Sec 12278.6(b))			
a. Access Street (Airport Blvd & New Hwy 29 access prohibited)	Primary access on Devlin Road. Secondary access on Airport Blvd.		X
b. Separation (200 ft. minimum along collectors required)	323' center to center on Devlin Rd. R/W to Center 294' from Airport Blvd	X	
c. Curb Cuts (minimization required)	4 access points, three on Devlin Rd., one on Airport Blvd.	X	
	A minimum of 2 access points for each portion are provided.		

ITEM	PROPOSAL	COMPLIANCE	
		YES	NO
d. Shared Driveways (required whenever possible)	Two driveways proposed per site (north/south). Each site will share driveways.	X	
e. Adjacent Lot Connections (required whenever possible)	N/A		
9. Parking (page 10- Sec 12278.7)	771 proposed 781 potential (10 "future" spaces)	X	
a. On-Site Spaces (_____)+			
b. Street Spaces (prohibited)+	None		
c. Space Width (9 ft)+	standard = 9' Compact = 8'	X	
d. Space Length (18 1/2-20 ft angled; 19 ft perpendicular)+	Min. 16'- Compact; Min. 19- Regular	X	
e. Space Back-up Area (14-18 Ft angled; 26 ft perpendicular)+	25'		X
f. Surface (dust-free, all-weather required)+	AC or PCC	X	
10. Loading (page 11- Sec 12278.8)	6 depressed docks with 36 bays. 11 at-grade doors	X	
a. On-Site Spaces (_____)+ *			
b. Street Spaces (prohibited)+ *	None proposed	X	
c. Space Location (front setback & public street facing locations prohibited)+	Inside rear of side areas shielded by solid walls	X	
d. Space Width (12 ft minimum)+	12' Minimum	X	
e. Space Length (40 ft minimum)+	40' Minimum	X	
f. Space Vertical Clearance (14 ft minimum)+	14' Minimum	X	
11. Outdoor Storage (page 4- Sec 12278.1(e)(1) & page 12 - Sec. 12278.8(d)(4))	None proposed	X	
a. Permanent (prohibited)+			
b. Surface (rolled-rock or better required)+ *	N/A		

ITEM	PROPOSAL	COMPLIANCE	
		YES	NO
12. Walkways (page 12- Sec 12278.9)	See site plan enclosed	X	
a. Nature (meandering ones required along arterials & collectors)+			
b. Location (within landscaped setback on both sides all arterials & collectors; one side all minor streets)+	See site plan enclosed	X	
c. Connection to Walkways On Adjoining Lots (required)	See site plan enclosed	X	
d. Materials (concrete required)	Concrete	X	
e. Width (5 ft minimum on Airport Blvd)	5' min. - Airport Blvd. 4' min. - Devlin Rd.	X	
13. Landscaping (page 13- Sec 12278.10 & page 11- Sec 12278.7(d))			
a. Complete Landscape Plan (submittal required)	Enclosed with this Submittal	X	
b. Landscape & Sidewalk Master Plan Consistency (required)	Yes	X	
c. High Standard of Landscape Design (required)	Per Standards	X	
d. Percent of Parcel Landscaped (20% minimum for 30 acres & smaller parcels; 15% for parcels larger than 30 acres)+ *	17% +/--including undisturbed wetland, detention and landscape area.	X	
e. Percent of Area Between Curb. & Minimum Setback Line Mounded & Planted in Lawn (50%)+	See Landscape Plan	X	
f. Landscaped Yards			
(1) front**(_____ ft minimum)+ *	35' min.-Airport Blvd. 25' min.-Devlin Road	X X	
(2) left side (_____ ft minimum)+ ***	10' min.	X	
(3) right side (_____ ft minimum)+ ***	10' min.	X	
(4) rear (_____ ft minimum)+ ***	10' min.	X	
(5) railroad frontage (10 ft minimum between bldg and parking lot)+	N/A		

ITEM	PROPOSAL	COMPLIANCE	
		YES	NO
g. Parking Lots			
(1) street-level view screening (required)	Proposed	X	
(2) parking lot tree/space ratios			
(a) double-loaded stalls (1 tree/6 spaces minimum)	See Landscape Plan	X	
(b) single-loaded stalls (1 tree/3 spaces minimum)	See Landscape Plan	X	
h. Landscaping of Unused Portions of Parcel (required)*	Proposed	X	
i. Immediate Landscaping of Entire Street Frontage (required)	Proposed per code	X	
j. Tree Standards			
(1) mature height (35 ft maximum)	See Landscape Plan	X	
(2) distance from intersection curb returns (25 ft minimum)	See Landscape Plan	X	
(3) utility poles (10 ft minimum)	See Site Plan	X	
(4) fire hydrants (10 ft minimum)	See Site Plan	X	
(5) driveways (10 ft minimum)	See Site Plan	X	
(6) street lights (10 ft from drip line when mature)	See Site Plan	X	
(7) curbs (4 ft minimum)	See Site Plan	X	
k. Shrub Standards			
(1) mature height (3 1/2 ft in street right-of way)	See Landscape Plan	X	
l. Native &/or Drought - Tolerant Plants (required in street right-of-ways)	See Landscape Plan	X	
m. Hardy, Long-Lived & Low Maintenance Plants (required in street right-of-ways)	See Landscape Plan	X	

ITEM	PROPOSAL	COMPLIANCE	
		YES	NO
n. Special Intersection Treatments (required)	Special treatment at SR29 and Airport and at Devlin and Airport. See Architectural and landscape plans	X	
o. Automated Comprehensive Irrigation System (required)	Per Code	X	
14. Existing Vegetation (page 16-Secs 12278.10 (f)(1) & (g))			
a. Mature Native & Naturalized Trees & Shrubs (preservation required)			X
b. Trees Removed (minimized)	4 eucalyptus trees 46 oak Trees		X
c. Replacement Specimen Trees (required)	364+/- proposed trees 93+/- native oaks	X	
d. Standard Oak Tree Damage Prevention Techniques (required)	Trees not to be removed will have protective fencing	X	
e. Special Grading Damage Protection Measures (required)	N/A	X	
15. Signs (page 17-Sec 12278.11(a)-(d))			
a. Detached Business Identification Signs			
(1) number (one/development maximum)+	3 signs plus 2 monuments with signs	X	
(2) information (name & symbol of business or bldg name, street name & number)+	Name, symbol, street name & number	X	
(3) form (low-profile wall type)+	See Architectural plans	X	
(4) height (4 ft maximum)+	See Architectural plans	X	
(5) message area (32 ft ² maximum)+	See Architectural plans	X	
(6) materials (wood, concrete, slumpstone, brick, enameled or anodized metal)+	See Architectural plans	X	
(7) building materials match (required)+	See Architectural plans	X	
(8) illumination (external)+	See Architectural plans	X	
b. Mounted Business Identification Signs			

ITEM	PROPOSAL	COMPLIANCE	
		YES	NO
(1) number (one/bldg maximum)+	See Architectural plans		X
(2) information (name, symbol & address of business)+	See Architectural plans	X	
(3) form (attached to wall)+	Attached to wall	X	
(4) fascia & roof signs (prohibited)+	See Architectural plans	X	
(5) total area (3% maximum of walls on bldg face)+	See Architectural plans	X	
(6) area/occupant (proportional to proportion of space within bldg occupied)+	N/A		
(7) materials (compliment those of structure)+	Would compliment structure	X	
(8) integration with bldg (required)+	Per code	X	
(9) illumination (external)+	See Architectural plans	X	
c. Permanent Informational Signs			
(1) information (street & industrial park names, etc)	N/A		
(2) height (12 ft maximum)	N/A		
(3) area (6 ft ² maximum)	N/A		
(4) coordination with master sign program (required)	N/A		
16. Lighting (page 18- Sec 12278.11(e))			
a. Highlighting of Entrances and Architectural & Landscaping Features (required)+ **	See Architectural plans	X	
b. Glare & Aviation Hazard Prevention (required)	Per code	X	
17. Streets (page 19- Sec 12278.12 & Page 26- Sec 12279)			

ITEM	PROPOSAL	COMPLIANCE	
		YES	NO
a. Adequate Street Access (required)	frontage on Airport Blvd frontage on Devlin Road	X	
b. Street Extension to Far Property Line (required)	N/A	X	
c. Fronting Right-of-Way Dedications (required)	Per code	X	
d. Right-of-Way Widths			
(1) arterials (95 ft minimum)	Airport Blvd. - 106'	X	
(2) 4-lane collectors (81 ft minimum)	N/A		
(3) 3-lane collectors (68 ft minimum)	Devlin Rd. - 68'proposed	X	
(4) 2-lane collectors & minor streets (56 ft minimum)	N/A		
e. Full Improvement of Fronting Street Sections (required except when planned roadway runs between 2 parcels)	Full imp. to Airport are existing. Devlin to be built to full width.	X	
f. Integrated Street Lights, Traffic Signals and Vehicular & Pedestrian Signing (required)	to match existing	X	
g. On-Street Bike Lanes (required along all arterials & collectors)	Existing on Airport. Per Specific Plan on Devlin Rd.	X	
h. Left Turn Lanes (Kelly Rd and 2-Lane Portion of Planned Devlin Rd Extension)	Continuous center lane in Devlin Road	X	
i. Street Light/Roadway Signs Consistency With Street Landscape & Sidewalk Plan (required)	Per code	X	
j. Improvements Consistent with Specific Plan Design Standards (required)	Per code	X	
18. Drainage/Inundation Protection (page 20- Sec 12278.13)	Per Napa County Flood Control & Water Conservation District	X	
a. Urban-level Inundation Protection Provided (required)			

ITEM	PROPOSAL	COMPLIANCE	
		YES	NO
b. Intensification of Downstream Flooding (prohibited)	Post project flows to be attenuated to pre-project conditions	X	
c. Storm Drain & Flood Control Channel Extension to Far Property Line (required)	N/A		
d. Fronting Right-of-Way Dedications (required)	to be provided as required	X	
e. Master Flood Control/Storm Drainage Plan (preparation required if none exists)	See preliminary Drainage Report enclosed	X	
f. Improvements Consistent with Pertinent Plans (required)*	See Drainage Plan	X	
19. Utilities (page 21- Sec 12278.14)	American Canyon water Service provider; Napa Sanitation Dist.	X	
a. Public Water & Sewer Service (required)		X	
b. Uncommitted Capacity of Public Water Supply/Sewage Treatment Exceedance (prohibited)+	No	X	
c. Other Necessary Standard Utilities Provided (required)	Per code	X	
d. Utility Main & Trunk Line Extensions to Far Property Line (required)	Utility lines would be extended to property line	X	
e. Utility Location (underground)	New to be underground Exist. overhead to remain	X	
f. Utility Installation (concurrent with roadways required unless installation in unpaved portion of right-of-way possible)	Concurrent with roadways	X	
20. Special Utility Service Center Development Standards (page 22-Sec 12278.15)			
a. Screening From All Streets And Where Possible Adjacent Uses (required)+	N/A	X	
b. Side & Rear Landscaping Screen (20 ft minimum against other IP-zoned lands)+ *	side & rear landscaping proposed	X	
c. Noise Barrier (required against other IP-and residentially-zoned lands)+ *	N/A		

ITEM	PROPOSAL	COMPLIANCE	
		YES	NO
21. Watercourses (page 23-Sec 12278.16)			
a. Development Setback (_____ ft from top of bank)***	None proposed		
b. Developable Area Reduction (35% maximum for pre-May, 1987 parcels)*	N/A		
c. Storage of Equipment or Materials, Installation of Surfacing, or Construction of Bldgs or Fences Within Required Setback (prohibited)+	N/A		
d. Conservation Easement (required along Soscol Creek)*	N/A		
e. Access Easement (10 ft required along back of development along Soscol Creek)*	N/A		
f. Riparian Plantings+ *	N/A		
22. Performance Standards (page 24-Secs 12278.17 & .18; page 25-Sec 12278.19)			
a. Hazardous, Toxic, Highly Flammable and/or Explosive Materials (list required)+	None Proposed		
b. Hazardous, Toxic, Highly Flammable and/or Explosive Materials Storage & Handling (adequate safety devices required)+	None Proposed		
c. Spill Containment & Clean-up Plan (required)+	N/A		
d. Solid & Liquid Waste Discharge (prohibited except in compliance with standards of sewage agency & RWQCB)+	Project will meet Standards	X	
e. Vibration, Heat or Glare Creation (discernable levels prohibited off-site)+	None would be created	X	
f. Smoke, Dust, Fumes or Contaminant Creation (discernable levels prohibited off-site)+	None would be created	X	

ITEM	PROPOSAL	COMPLIANCE	
		YES	NO
g. Odor Creation (discernable levels prohibited off-site)+	None would be created	X	
h. Annoying Noise Creation (discernable levels prohibited off-site)+	None would be created	X	
i. Dangerous Levels of Radioactivity (prohibited)+	None	X	
j. Electrical Disturbance or Electromagnetic Interference Creation (discernable levels prohibited off-site)+	None	X	

U.S. GEOLOGICAL SURVEY (USGS) TOPOGRAPHICAL SITE LOCATION MAP
QUADRANGLE TITLE: CORDELIA & CUTTINGS WHARF FILE NO.:

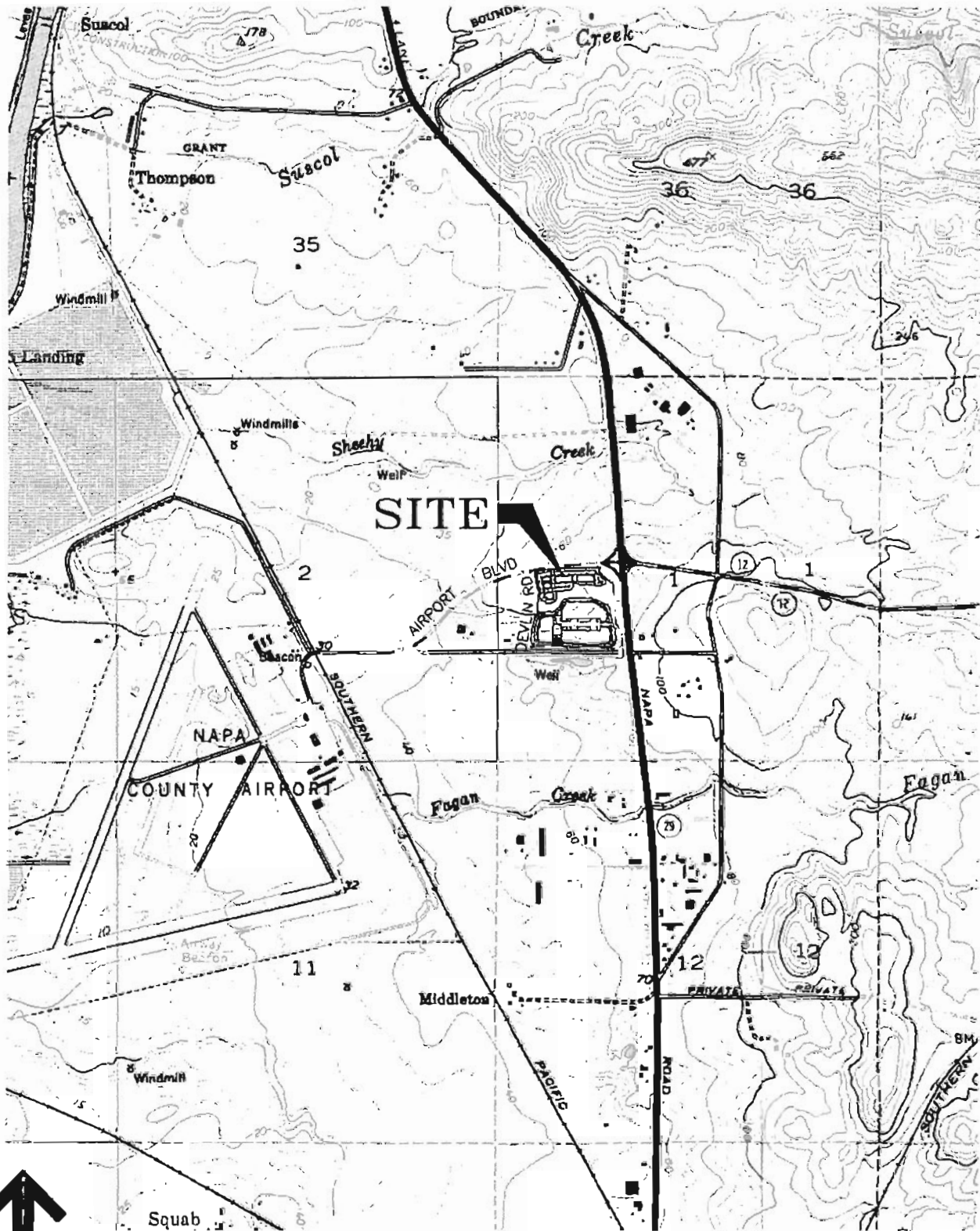

1" = 2000'

NAPA COMMERCE CENTER

NAPA COUNTY, CALIFORNIA
TENTATIVE PARCEL MAP

MARCH 2000
SHEET 2 OF 4



PROJECT DESCRIPTION

THE PROJECT IS A TENTATIVE PARCEL MAP FOR THE DEVELOPMENT OF A COMMERCE CENTER IN NAPA COUNTY, CALIFORNIA. THE PROJECT IS SITUATED ON A 100-ACRE TRACT OF LAND, MORE OR LESS, AS SHOWN ON THE ATTACHED MAPS. THE PROJECT IS TO BE DEVELOPED AS A COMMERCE CENTER AND WILL CONSIST OF SEVERAL BUILDINGS, PARKING AREAS, AND OTHER FACILITIES. THE PROJECT IS TO BE DEVELOPED IN ACCORDANCE WITH THE ZONING ORDINANCES OF NAPA COUNTY, CALIFORNIA.

LAND USES

TRACT	ACRES	LAND USE
1	1.00	OFFICE
2	1.00	OFFICE
3	1.00	OFFICE
4	1.00	OFFICE
5	1.00	OFFICE
6	1.00	OFFICE
7	1.00	OFFICE
8	1.00	OFFICE
9	1.00	OFFICE
10	1.00	OFFICE
11	1.00	OFFICE
12	1.00	OFFICE
13	1.00	OFFICE
14	1.00	OFFICE
15	1.00	OFFICE
16	1.00	OFFICE
17	1.00	OFFICE
18	1.00	OFFICE
19	1.00	OFFICE
20	1.00	OFFICE
21	1.00	OFFICE
22	1.00	OFFICE
23	1.00	OFFICE
24	1.00	OFFICE
25	1.00	OFFICE
26	1.00	OFFICE
27	1.00	OFFICE
28	1.00	OFFICE
29	1.00	OFFICE
30	1.00	OFFICE
31	1.00	OFFICE
32	1.00	OFFICE
33	1.00	OFFICE
34	1.00	OFFICE
35	1.00	OFFICE
36	1.00	OFFICE
37	1.00	OFFICE
38	1.00	OFFICE
39	1.00	OFFICE
40	1.00	OFFICE
41	1.00	OFFICE
42	1.00	OFFICE
43	1.00	OFFICE
44	1.00	OFFICE
45	1.00	OFFICE
46	1.00	OFFICE
47	1.00	OFFICE
48	1.00	OFFICE
49	1.00	OFFICE
50	1.00	OFFICE

LEGEND

- EXISTING BUILDINGS
- EXISTING PARKING AREAS
- EXISTING DRIVEWAYS
- EXISTING UTILITIES
- EXISTING FENCES
- EXISTING TREES
- EXISTING ROADS
- EXISTING CURBS
- EXISTING SIDEWALKS
- EXISTING LIGHT FIXTURES
- EXISTING SIGNAGE
- EXISTING LANDSCAPING
- EXISTING UTILITIES
- EXISTING FENCES
- EXISTING TREES
- EXISTING ROADS
- EXISTING CURBS
- EXISTING SIDEWALKS
- EXISTING LIGHT FIXTURES
- EXISTING SIGNAGE
- EXISTING LANDSCAPING

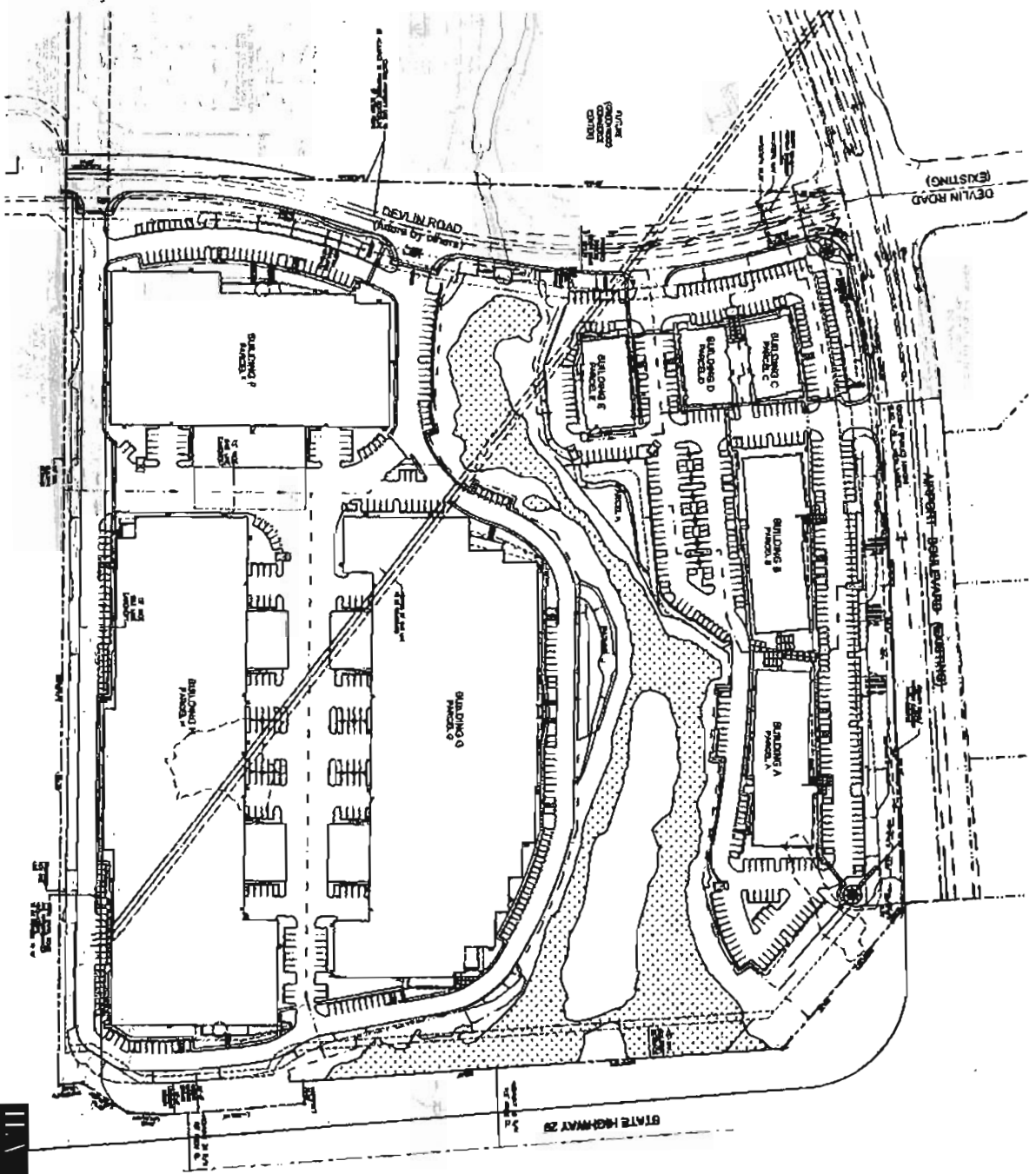
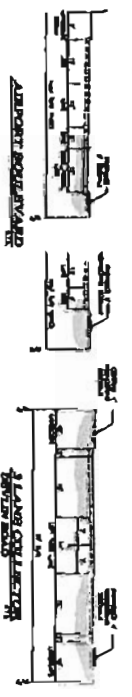

ARCHITECT/ENGINEER
NAME
ADDRESS
CITY, STATE, ZIP

DATE
SCALE

USE PERMIT SUBMITTAL DRAWINGS FOR: NAPA COMMERCE CENTER



17th Street Road
Napa, CA 94558
Phone: 707.253.1100
Fax: 707.253.1101
www.napacomm.com

Napa 34 Holdings, LLC
17th Street Road
Napa, CA 94558

NAPA COMMERCE CENTER
NAPA 34 HOLDINGS, LLC
17TH STREET ROAD
NAPA, CALIFORNIA 94558

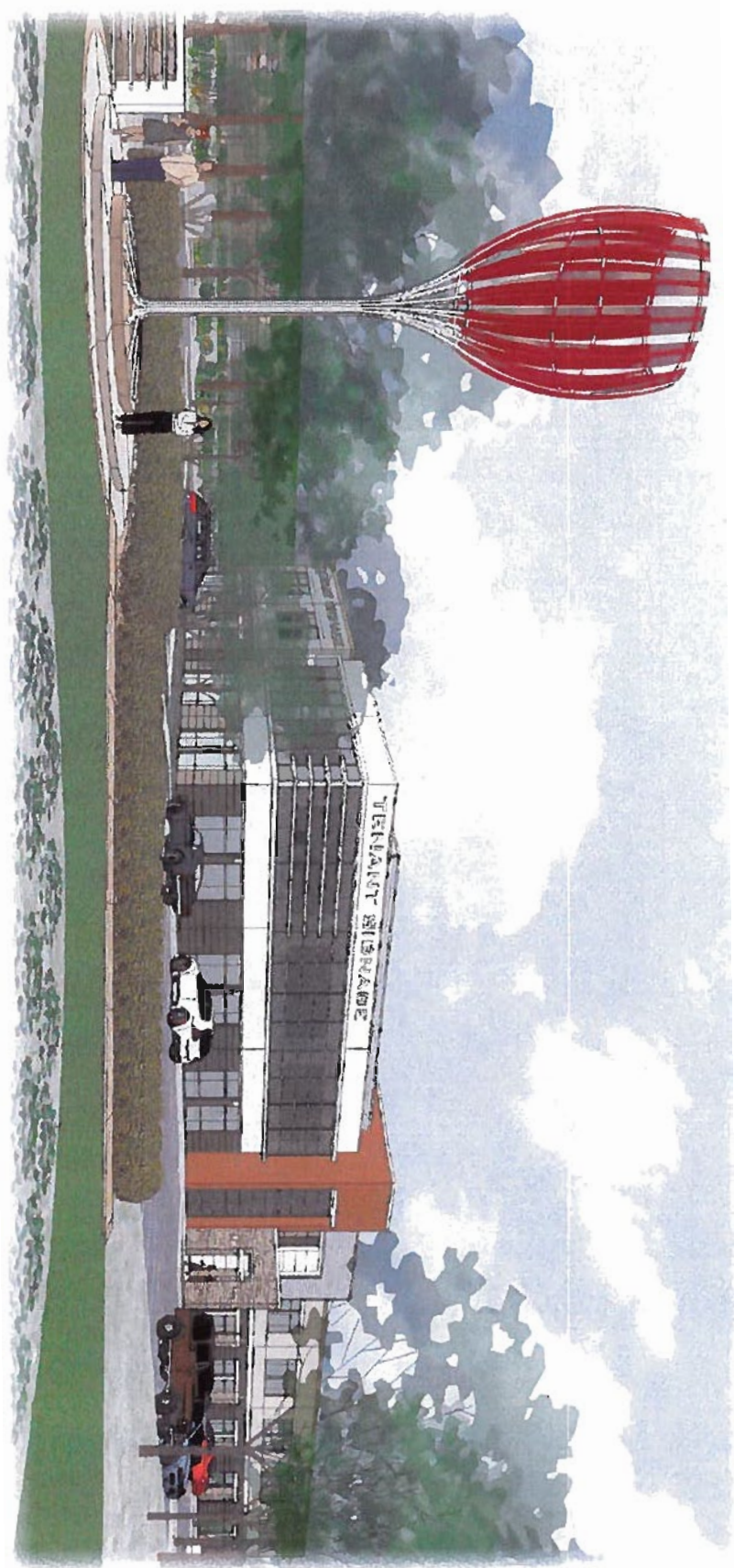

SITE PARALLEL PERSPECTIVE AS SEEN FROM THE INTERSECTION OF HIGHWAY 12 & HIGHWAY 29 FACING THE SOUTH WEST

PROJECT NARRATIVE

The project is a 100,000 square foot commercial building located at the intersection of Highway 12 and Highway 29 in Napa, California. The building is a modern, multi-story structure with large windows and a flat roof. The site is landscaped with trees and a paved walkway. The project is owned by Napa 34 Holdings, LLC and is being developed by Napa Commerce Center. The building will be used for commercial purposes and will provide a modern workspace for businesses in the Napa area. The project is a key component of the Napa Commerce Center development and will help to revitalize the downtown area. The building is designed to be energy-efficient and sustainable, with features such as solar panels and water-saving fixtures. The project is expected to be completed in late 2023 and will provide a significant boost to the local economy. The building will be a landmark addition to the Napa skyline and will attract new businesses and residents to the area. The project is a testament to the commitment of Napa Commerce Center to creating a vibrant and thriving downtown Napa.

VELOCITY MAP



PROJECT TEAM

COMPANY	ROLE	CONTACT
ARCHITECT	ARCHITECT	ARCHITECT
ENGINEER	ENGINEER	ENGINEER
LANDSCAPE ARCHITECT	LANDSCAPE ARCHITECT	LANDSCAPE ARCHITECT
PLANNING	PLANNING	PLANNING
PERMITS	PERMITS	PERMITS
CONSTRUCTION	CONSTRUCTION	CONSTRUCTION
OPERATIONS	OPERATIONS	OPERATIONS
MAINTENANCE	MAINTENANCE	MAINTENANCE
SECURITY	SECURITY	SECURITY
ENVIRONMENTAL	ENVIRONMENTAL	ENVIRONMENTAL
ENERGY	ENERGY	ENERGY
WATER	WATER	WATER
WASTE	WASTE	WASTE
TRANSPORTATION	TRANSPORTATION	TRANSPORTATION
UTILITIES	UTILITIES	UTILITIES
TELECOMMUNICATIONS	TELECOMMUNICATIONS	TELECOMMUNICATIONS
SALES	SALES	SALES
MARKETING	MARKETING	MARKETING
FINANCE	FINANCE	FINANCE
LEGAL	LEGAL	LEGAL
TAX	TAX	TAX
INSURANCE	INSURANCE	INSURANCE
RETIRES	RETIRES	RETIRES
HEALTHCARE	HEALTHCARE	HEALTHCARE
EDUCATION	EDUCATION	EDUCATION
RECREATION	RECREATION	RECREATION
HOUSING	HOUSING	HOUSING
TRANSPORTATION	TRANSPORTATION	TRANSPORTATION
UTILITIES	UTILITIES	UTILITIES
TELECOMMUNICATIONS	TELECOMMUNICATIONS	TELECOMMUNICATIONS
SALES	SALES	SALES
MARKETING	MARKETING	MARKETING
FINANCE	FINANCE	FINANCE
LEGAL	LEGAL	LEGAL
TAX	TAX	TAX
INSURANCE	INSURANCE	INSURANCE
RETIRES	RETIRES	RETIRES
HEALTHCARE	HEALTHCARE	HEALTHCARE
EDUCATION	EDUCATION	EDUCATION
RECREATION	RECREATION	RECREATION
HOUSING	HOUSING	HOUSING

SHEET INDEX

NO.	DESCRIPTION
1	COVER SHEET
2	GENERAL NOTES
3	FOUNDATION
4	FLOOR SLAB
5	ROOF
6	MECHANICAL
7	ELECTRICAL
8	PLUMBING
9	LANDSCAPE
10	PERMITS
11	CONSTRUCTION
12	OPERATIONS
13	MAINTENANCE
14	SECURITY
15	ENVIRONMENTAL
16	ENERGY
17	WATER
18	WASTE
19	TRANSPORTATION
20	UTILITIES
21	TELECOMMUNICATIONS
22	SALES
23	MARKETING
24	FINANCE
25	LEGAL
26	TAX
27	INSURANCE
28	RETIRES
29	HEALTHCARE
30	EDUCATION
31	RECREATION
32	HOUSING



COVER SHEET

A00.1

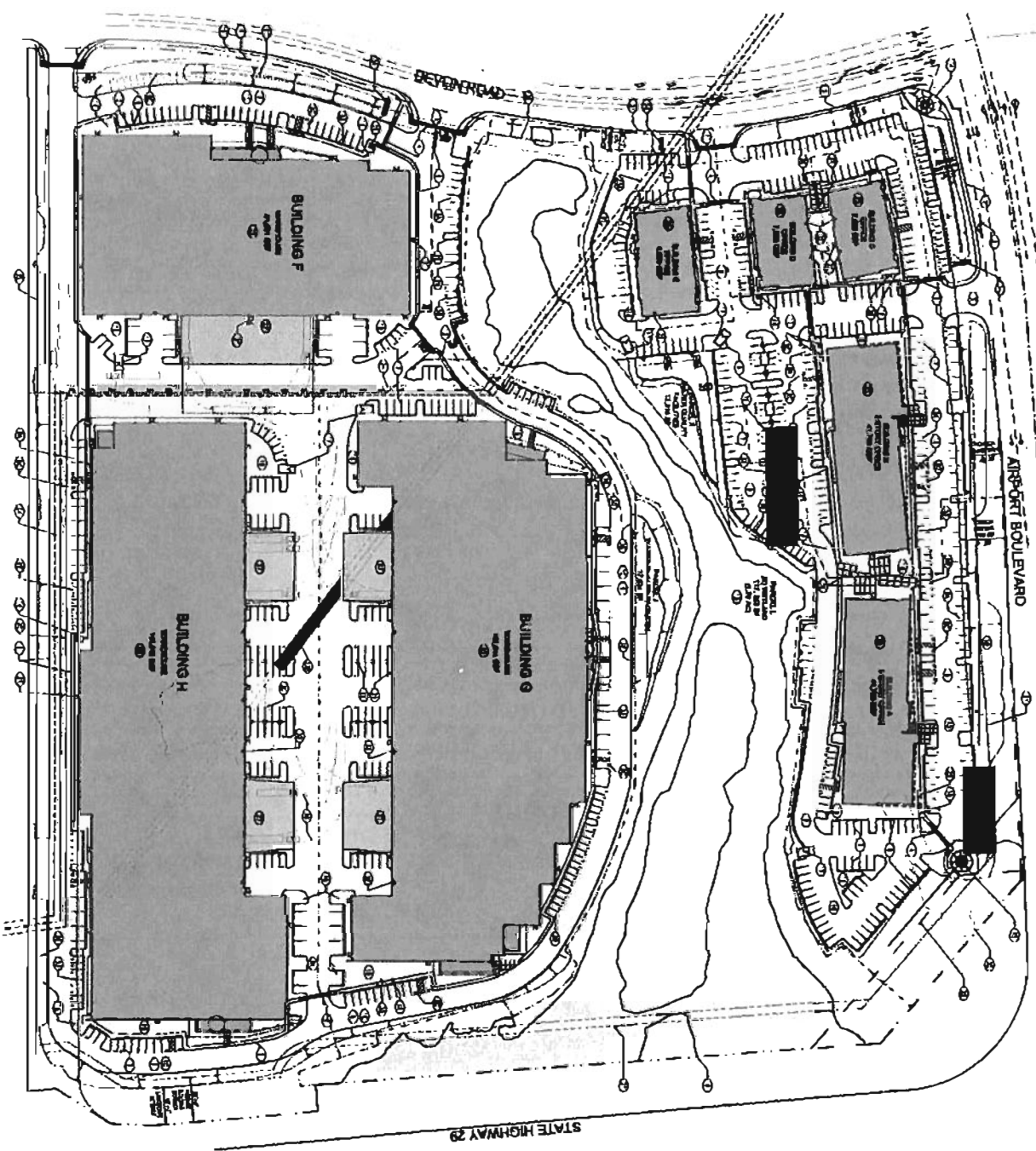

REGULATORY SITE MATTER PLAN
DATE: 7-27-17

1

REVISIONS:

- 1. 07/27/17: Initial design.
- 2. 08/01/17: Revised site plan.
- 3. 08/01/17: Revised site plan.
- 4. 08/01/17: Revised site plan.
- 5. 08/01/17: Revised site plan.
- 6. 08/01/17: Revised site plan.
- 7. 08/01/17: Revised site plan.
- 8. 08/01/17: Revised site plan.
- 9. 08/01/17: Revised site plan.
- 10. 08/01/17: Revised site plan.
- 11. 08/01/17: Revised site plan.
- 12. 08/01/17: Revised site plan.
- 13. 08/01/17: Revised site plan.
- 14. 08/01/17: Revised site plan.
- 15. 08/01/17: Revised site plan.
- 16. 08/01/17: Revised site plan.
- 17. 08/01/17: Revised site plan.
- 18. 08/01/17: Revised site plan.
- 19. 08/01/17: Revised site plan.
- 20. 08/01/17: Revised site plan.
- 21. 08/01/17: Revised site plan.
- 22. 08/01/17: Revised site plan.
- 23. 08/01/17: Revised site plan.
- 24. 08/01/17: Revised site plan.
- 25. 08/01/17: Revised site plan.
- 26. 08/01/17: Revised site plan.
- 27. 08/01/17: Revised site plan.
- 28. 08/01/17: Revised site plan.
- 29. 08/01/17: Revised site plan.
- 30. 08/01/17: Revised site plan.
- 31. 08/01/17: Revised site plan.
- 32. 08/01/17: Revised site plan.
- 33. 08/01/17: Revised site plan.
- 34. 08/01/17: Revised site plan.
- 35. 08/01/17: Revised site plan.
- 36. 08/01/17: Revised site plan.
- 37. 08/01/17: Revised site plan.
- 38. 08/01/17: Revised site plan.
- 39. 08/01/17: Revised site plan.
- 40. 08/01/17: Revised site plan.
- 41. 08/01/17: Revised site plan.
- 42. 08/01/17: Revised site plan.
- 43. 08/01/17: Revised site plan.
- 44. 08/01/17: Revised site plan.
- 45. 08/01/17: Revised site plan.
- 46. 08/01/17: Revised site plan.
- 47. 08/01/17: Revised site plan.
- 48. 08/01/17: Revised site plan.
- 49. 08/01/17: Revised site plan.
- 50. 08/01/17: Revised site plan.
- 51. 08/01/17: Revised site plan.
- 52. 08/01/17: Revised site plan.
- 53. 08/01/17: Revised site plan.
- 54. 08/01/17: Revised site plan.
- 55. 08/01/17: Revised site plan.
- 56. 08/01/17: Revised site plan.
- 57. 08/01/17: Revised site plan.
- 58. 08/01/17: Revised site plan.
- 59. 08/01/17: Revised site plan.
- 60. 08/01/17: Revised site plan.
- 61. 08/01/17: Revised site plan.
- 62. 08/01/17: Revised site plan.
- 63. 08/01/17: Revised site plan.
- 64. 08/01/17: Revised site plan.
- 65. 08/01/17: Revised site plan.
- 66. 08/01/17: Revised site plan.
- 67. 08/01/17: Revised site plan.
- 68. 08/01/17: Revised site plan.
- 69. 08/01/17: Revised site plan.
- 70. 08/01/17: Revised site plan.
- 71. 08/01/17: Revised site plan.
- 72. 08/01/17: Revised site plan.
- 73. 08/01/17: Revised site plan.
- 74. 08/01/17: Revised site plan.
- 75. 08/01/17: Revised site plan.
- 76. 08/01/17: Revised site plan.
- 77. 08/01/17: Revised site plan.
- 78. 08/01/17: Revised site plan.
- 79. 08/01/17: Revised site plan.
- 80. 08/01/17: Revised site plan.
- 81. 08/01/17: Revised site plan.
- 82. 08/01/17: Revised site plan.
- 83. 08/01/17: Revised site plan.
- 84. 08/01/17: Revised site plan.
- 85. 08/01/17: Revised site plan.
- 86. 08/01/17: Revised site plan.
- 87. 08/01/17: Revised site plan.
- 88. 08/01/17: Revised site plan.
- 89. 08/01/17: Revised site plan.
- 90. 08/01/17: Revised site plan.
- 91. 08/01/17: Revised site plan.
- 92. 08/01/17: Revised site plan.
- 93. 08/01/17: Revised site plan.
- 94. 08/01/17: Revised site plan.
- 95. 08/01/17: Revised site plan.
- 96. 08/01/17: Revised site plan.
- 97. 08/01/17: Revised site plan.
- 98. 08/01/17: Revised site plan.
- 99. 08/01/17: Revised site plan.
- 100. 08/01/17: Revised site plan.

SITE STATISTICS:

Item	Quantity	Notes
Total Site Area	100,000 sq ft	
Building Footprint	50,000 sq ft	
Parking Spaces	200	
Landscaping Area	10,000 sq ft	
Driveway Area	5,000 sq ft	
Other	10,000 sq ft	

REGULATORY

7/27/17
7/27/17
7/27/17

NAPA HOLDINGS LLC

REGULATORY MATTER PLAN

NAPA COMMERCE CENTER

Item	Quantity	Notes
Building Footprint	50,000 sq ft	
Parking Spaces	200	
Landscaping Area	10,000 sq ft	
Driveway Area	5,000 sq ft	
Other	10,000 sq ft	

SITE PLAN

A01.1

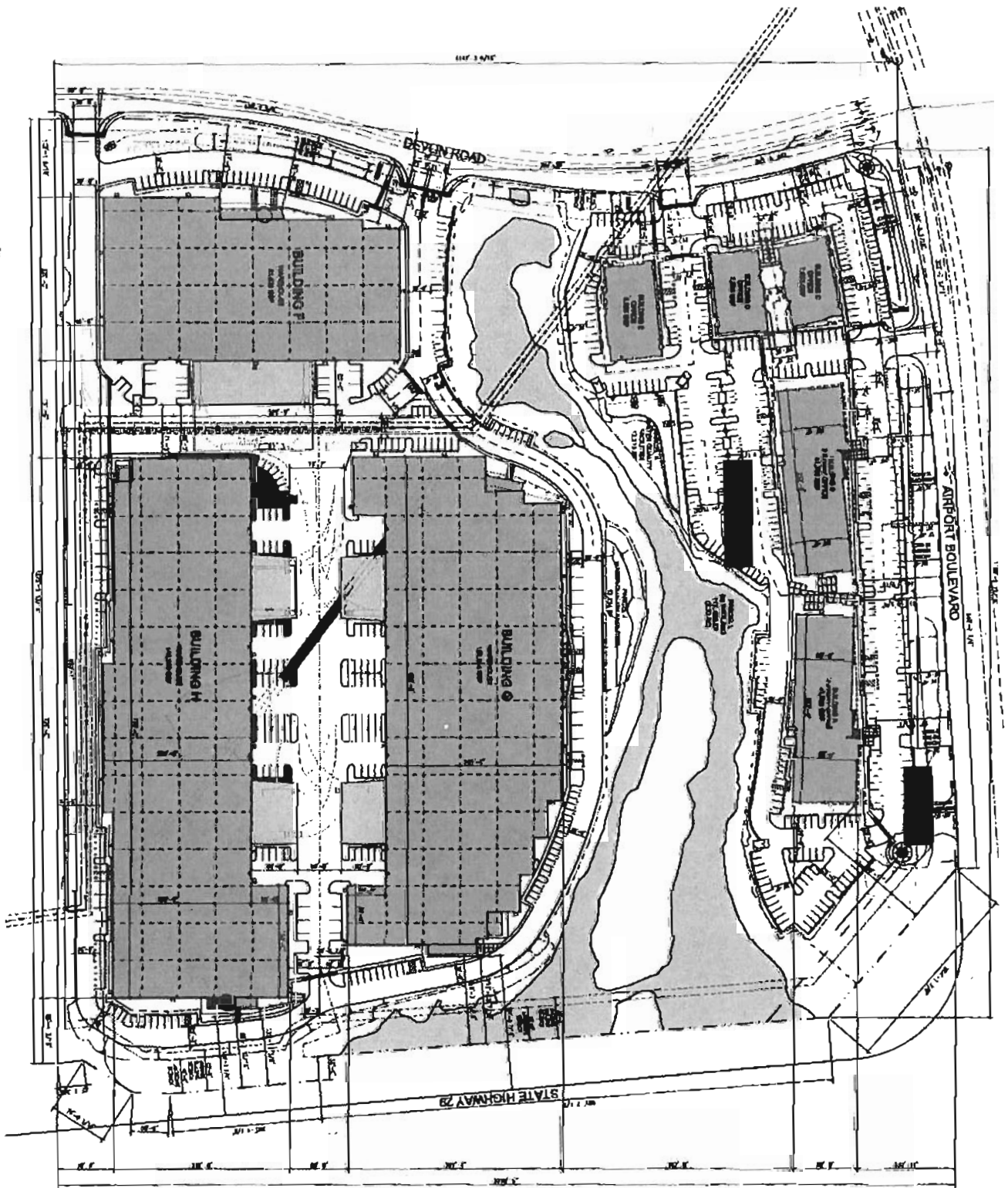

PROPOSED SITE PLAN

1

**DIMENSIONED
SITE PLAN**

A01.2

NO.	DATE	BY	REVISION
1	08/11/11	BR/ML	ISSUED FOR PERMITTING
2	08/11/11	BR/ML	ISSUED FOR PERMITTING
3	08/11/11	BR/ML	ISSUED FOR PERMITTING
4	08/11/11	BR/ML	ISSUED FOR PERMITTING
5	08/11/11	BR/ML	ISSUED FOR PERMITTING
6	08/11/11	BR/ML	ISSUED FOR PERMITTING
7	08/11/11	BR/ML	ISSUED FOR PERMITTING
8	08/11/11	BR/ML	ISSUED FOR PERMITTING
9	08/11/11	BR/ML	ISSUED FOR PERMITTING
10	08/11/11	BR/ML	ISSUED FOR PERMITTING



NO.	DATE	BY	REVISION
1	08/11/11	BR/ML	ISSUED FOR PERMITTING
2	08/11/11	BR/ML	ISSUED FOR PERMITTING
3	08/11/11	BR/ML	ISSUED FOR PERMITTING
4	08/11/11	BR/ML	ISSUED FOR PERMITTING
5	08/11/11	BR/ML	ISSUED FOR PERMITTING
6	08/11/11	BR/ML	ISSUED FOR PERMITTING
7	08/11/11	BR/ML	ISSUED FOR PERMITTING
8	08/11/11	BR/ML	ISSUED FOR PERMITTING
9	08/11/11	BR/ML	ISSUED FOR PERMITTING
10	08/11/11	BR/ML	ISSUED FOR PERMITTING

**NAPA
COMMERCE
CENTER**

Napa 34 Holdings LLC

BRIAN KAUFMAN
ARCHITECT
12345 MARKET STREET
NAPA, CALIFORNIA 94930
TEL: 707.251.1234
WWW.BRIANKAUFMAN.COM



A: PROPOSED BALLOON SCULPTURE

- KEYNOTE:**
- 1. BALLOON SCULPTURE
 - 2. BALLOON SCULPTURE
 - 3. BALLOON SCULPTURE
 - 4. BALLOON SCULPTURE
 - 5. BALLOON SCULPTURE
 - 6. BALLOON SCULPTURE
 - 7. BALLOON SCULPTURE
 - 8. BALLOON SCULPTURE
 - 9. BALLOON SCULPTURE
 - 10. BALLOON SCULPTURE
 - 11. BALLOON SCULPTURE
 - 12. BALLOON SCULPTURE
 - 13. BALLOON SCULPTURE
 - 14. BALLOON SCULPTURE
 - 15. BALLOON SCULPTURE
 - 16. BALLOON SCULPTURE
 - 17. BALLOON SCULPTURE
 - 18. BALLOON SCULPTURE
 - 19. BALLOON SCULPTURE
 - 20. BALLOON SCULPTURE
 - 21. BALLOON SCULPTURE
 - 22. BALLOON SCULPTURE
 - 23. BALLOON SCULPTURE
 - 24. BALLOON SCULPTURE
 - 25. BALLOON SCULPTURE
 - 26. BALLOON SCULPTURE
 - 27. BALLOON SCULPTURE
 - 28. BALLOON SCULPTURE
 - 29. BALLOON SCULPTURE
 - 30. BALLOON SCULPTURE
 - 31. BALLOON SCULPTURE
 - 32. BALLOON SCULPTURE
 - 33. BALLOON SCULPTURE
 - 34. BALLOON SCULPTURE
 - 35. BALLOON SCULPTURE
 - 36. BALLOON SCULPTURE
 - 37. BALLOON SCULPTURE
 - 38. BALLOON SCULPTURE
 - 39. BALLOON SCULPTURE
 - 40. BALLOON SCULPTURE
 - 41. BALLOON SCULPTURE
 - 42. BALLOON SCULPTURE
 - 43. BALLOON SCULPTURE
 - 44. BALLOON SCULPTURE
 - 45. BALLOON SCULPTURE
 - 46. BALLOON SCULPTURE
 - 47. BALLOON SCULPTURE
 - 48. BALLOON SCULPTURE
 - 49. BALLOON SCULPTURE
 - 50. BALLOON SCULPTURE
 - 51. BALLOON SCULPTURE
 - 52. BALLOON SCULPTURE
 - 53. BALLOON SCULPTURE
 - 54. BALLOON SCULPTURE
 - 55. BALLOON SCULPTURE
 - 56. BALLOON SCULPTURE
 - 57. BALLOON SCULPTURE
 - 58. BALLOON SCULPTURE
 - 59. BALLOON SCULPTURE
 - 60. BALLOON SCULPTURE
 - 61. BALLOON SCULPTURE
 - 62. BALLOON SCULPTURE
 - 63. BALLOON SCULPTURE
 - 64. BALLOON SCULPTURE
 - 65. BALLOON SCULPTURE
 - 66. BALLOON SCULPTURE
 - 67. BALLOON SCULPTURE
 - 68. BALLOON SCULPTURE
 - 69. BALLOON SCULPTURE
 - 70. BALLOON SCULPTURE
 - 71. BALLOON SCULPTURE
 - 72. BALLOON SCULPTURE
 - 73. BALLOON SCULPTURE
 - 74. BALLOON SCULPTURE
 - 75. BALLOON SCULPTURE
 - 76. BALLOON SCULPTURE
 - 77. BALLOON SCULPTURE
 - 78. BALLOON SCULPTURE
 - 79. BALLOON SCULPTURE
 - 80. BALLOON SCULPTURE
 - 81. BALLOON SCULPTURE
 - 82. BALLOON SCULPTURE
 - 83. BALLOON SCULPTURE
 - 84. BALLOON SCULPTURE
 - 85. BALLOON SCULPTURE
 - 86. BALLOON SCULPTURE
 - 87. BALLOON SCULPTURE
 - 88. BALLOON SCULPTURE
 - 89. BALLOON SCULPTURE
 - 90. BALLOON SCULPTURE
 - 91. BALLOON SCULPTURE
 - 92. BALLOON SCULPTURE
 - 93. BALLOON SCULPTURE
 - 94. BALLOON SCULPTURE
 - 95. BALLOON SCULPTURE
 - 96. BALLOON SCULPTURE
 - 97. BALLOON SCULPTURE
 - 98. BALLOON SCULPTURE
 - 99. BALLOON SCULPTURE
 - 100. BALLOON SCULPTURE

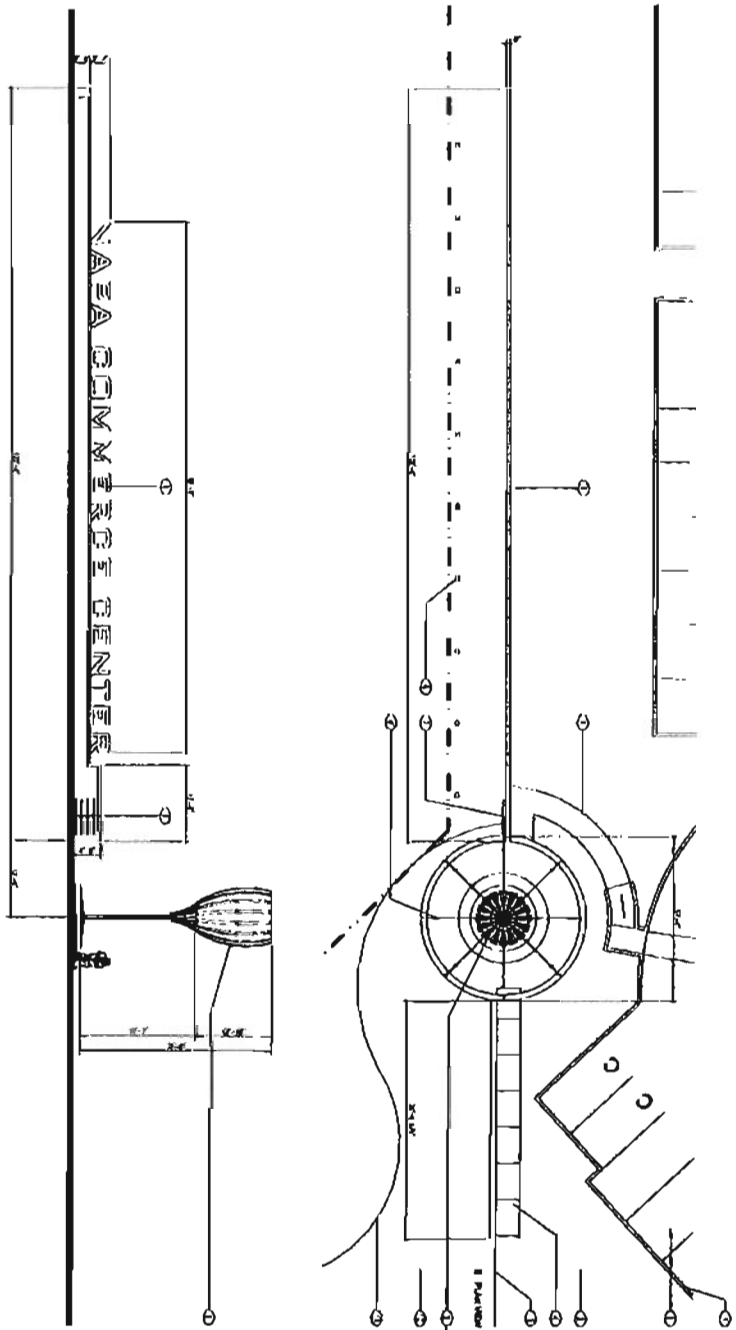

MONUMENT SIGNAGE AND SITE RELATIONS
SCALE: 1/8" = 1'-0"

1

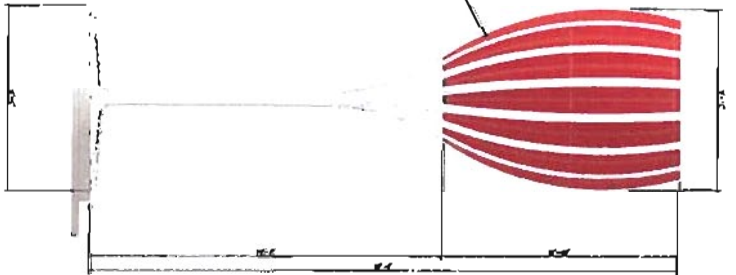

B: BALLOON SCULPTURE ELEVATION

NOTE: ALL DIMENSIONS ARE TO FACE UNLESS OTHERWISE NOTED. THIS DRAWING IS FOR INFORMATION ONLY AND DOES NOT CONSTITUTE A CONTRACT. THE CONTRACTOR SHALL BE RESPONSIBLE FOR OBTAINING ALL NECESSARY PERMITS AND APPROVALS FROM THE LOCAL, STATE, AND FEDERAL AUTHORITIES. THE CONTRACTOR SHALL BE RESPONSIBLE FOR OBTAINING ALL NECESSARY PERMITS AND APPROVALS FROM THE LOCAL, STATE, AND FEDERAL AUTHORITIES.

MONUMENT SIGNAGE

Project: A01.3

Scale: 1/8" = 1'-0"



DATE: 10/15/2024

PROJECT: NAPA COMMERCE CENTER

LOCATION: 1000 NAPA AVENUE, NAPA, CA 94559

CLIENT: NAPA HOLDINGS LLC

ARCHITECT: [FIRM NAME]

PROJECT NO: A01.3

DATE: 10/15/2024

SCALE: 1/8" = 1'-0"

PROJECT: NAPA COMMERCE CENTER

LOCATION: 1000 NAPA AVENUE, NAPA, CA 94559

CLIENT: NAPA HOLDINGS LLC

ARCHITECT: [FIRM NAME]

PROJECT NO: A01.3

DATE: 10/15/2024

SCALE: 1/8" = 1'-0"

PROJECT: NAPA COMMERCE CENTER

LOCATION: 1000 NAPA AVENUE, NAPA, CA 94559

CLIENT: NAPA HOLDINGS LLC

ARCHITECT: [FIRM NAME]

PROJECT NO: A01.3

DATE: 10/15/2024

SCALE: 1/8" = 1'-0"

PROJECT: NAPA COMMERCE CENTER

LOCATION: 1000 NAPA AVENUE, NAPA, CA 94559

CLIENT: NAPA HOLDINGS LLC

ARCHITECT: [FIRM NAME]

PROJECT NO: A01.3

DATE: 10/15/2024

SCALE: 1/8" = 1'-0"

PROJECT: NAPA COMMERCE CENTER

LOCATION: 1000 NAPA AVENUE, NAPA, CA 94559

CLIENT: NAPA HOLDINGS LLC

ARCHITECT: [FIRM NAME]

PROJECT NO: A01.3

DATE: 10/15/2024

SCALE: 1/8" = 1'-0"

PROJECT: NAPA COMMERCE CENTER

LOCATION: 1000 NAPA AVENUE, NAPA, CA 94559

CLIENT: NAPA HOLDINGS LLC

ARCHITECT: [FIRM NAME]

PROJECT NO: A01.3

DATE: 10/15/2024

SCALE: 1/8" = 1'-0"

PROJECT: NAPA COMMERCE CENTER

LOCATION: 1000 NAPA AVENUE, NAPA, CA 94559

CLIENT: NAPA HOLDINGS LLC

ARCHITECT: [FIRM NAME]

PROJECT NO: A01.3

DATE: 10/15/2024

SCALE: 1/8" = 1'-0"

PROJECT: NAPA COMMERCE CENTER

LOCATION: 1000 NAPA AVENUE, NAPA, CA 94559

CLIENT: NAPA HOLDINGS LLC

ARCHITECT: [FIRM NAME]

PROJECT NO: A01.3

DATE: 10/15/2024

SCALE: 1/8" = 1'-0"

PROJECT: NAPA COMMERCE CENTER

LOCATION: 1000 NAPA AVENUE, NAPA, CA 94559

CLIENT: NAPA HOLDINGS LLC

ARCHITECT: [FIRM NAME]

PROJECT NO: A01.3

DATE: 10/15/2024

SCALE: 1/8" = 1'-0"

PROJECT: NAPA COMMERCE CENTER

LOCATION: 1000 NAPA AVENUE, NAPA, CA 94559

CLIENT: NAPA HOLDINGS LLC

ARCHITECT: [FIRM NAME]

PROJECT NO: A01.3

DATE: 10/15/2024

SCALE: 1/8" = 1'-0"

PROJECT: NAPA COMMERCE CENTER

LOCATION: 1000 NAPA AVENUE, NAPA, CA 94559

CLIENT: NAPA HOLDINGS LLC

ARCHITECT: [FIRM NAME]

PROJECT NO: A01.3

DATE: 10/15/2024

PROJECT: NAPA COMMERCE CENTER

LOCATION: 1000 NAPA AVENUE, NAPA, CA 94559

CLIENT: NAPA HOLDINGS LLC

ARCHITECT: [FIRM NAME]

PROJECT NO: A01.3

DATE: 10/15/2024

SCALE: 1/8" = 1'-0"

PROJECT: NAPA COMMERCE CENTER

LOCATION: 1000 NAPA AVENUE, NAPA, CA 94559

CLIENT: NAPA HOLDINGS LLC

ARCHITECT: [FIRM NAME]

PROJECT NO: A01.3

DATE: 10/15/2024

SCALE: 1/8" = 1'-0"

PROJECT: NAPA COMMERCE CENTER

LOCATION: 1000 NAPA AVENUE, NAPA, CA 94559

CLIENT: NAPA HOLDINGS LLC

ARCHITECT: [FIRM NAME]

PROJECT NO: A01.3

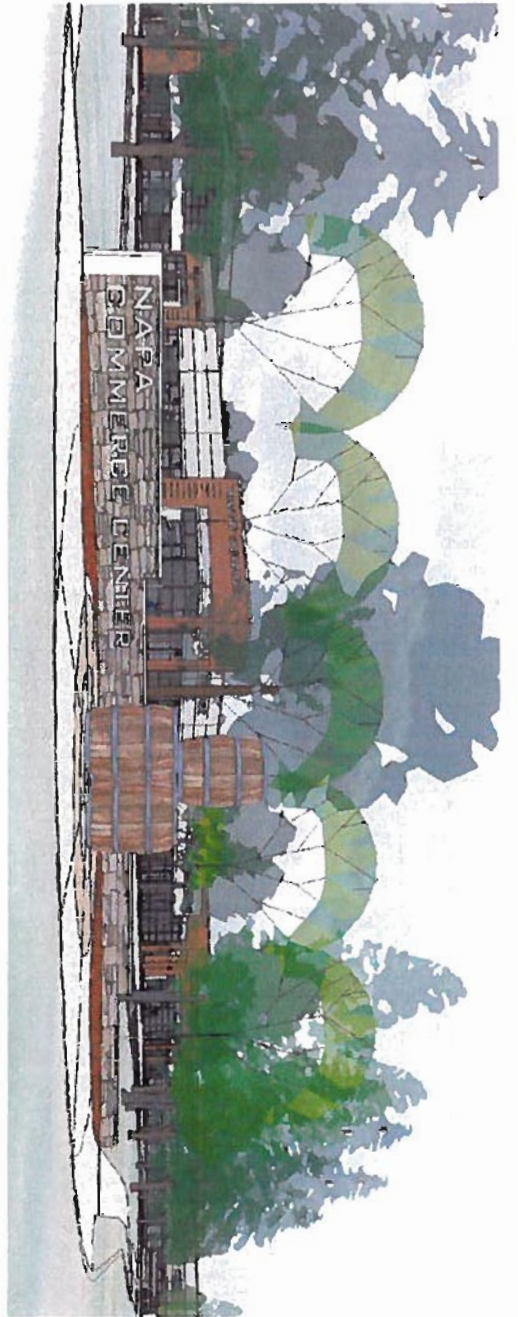

- KEYNOTES:**
- 1. SEE PLAN FOR SIGNAGE LOCATION AND DIMENSIONS.
 - 2. SEE PLAN FOR SIGNAGE LOCATION AND DIMENSIONS.
 - 3. SEE PLAN FOR SIGNAGE LOCATION AND DIMENSIONS.
 - 4. SEE PLAN FOR SIGNAGE LOCATION AND DIMENSIONS.
 - 5. SEE PLAN FOR SIGNAGE LOCATION AND DIMENSIONS.
 - 6. SEE PLAN FOR SIGNAGE LOCATION AND DIMENSIONS.
 - 7. SEE PLAN FOR SIGNAGE LOCATION AND DIMENSIONS.
 - 8. SEE PLAN FOR SIGNAGE LOCATION AND DIMENSIONS.
 - 9. SEE PLAN FOR SIGNAGE LOCATION AND DIMENSIONS.
 - 10. SEE PLAN FOR SIGNAGE LOCATION AND DIMENSIONS.

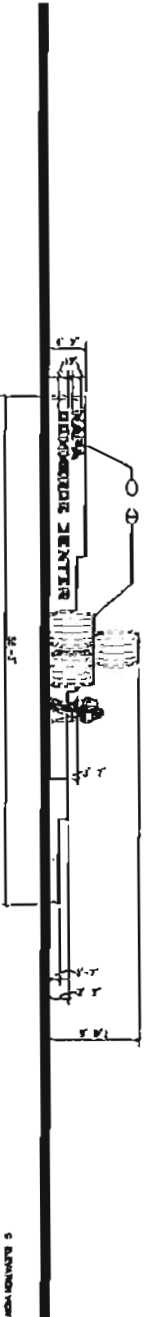
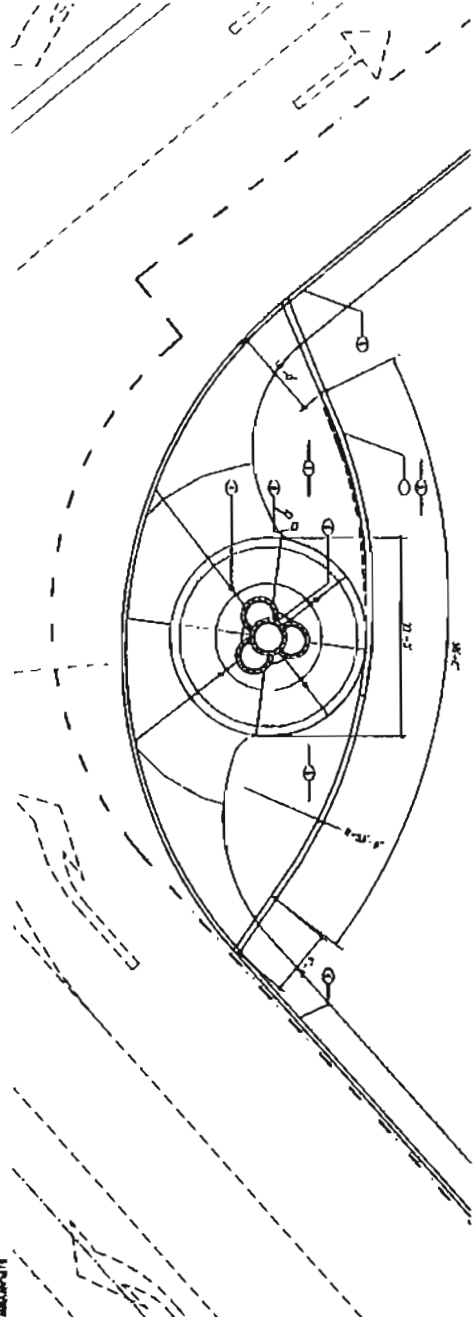

MONUMENT SIGNAGE AND SITE ELEVATION
 03/11/14

1

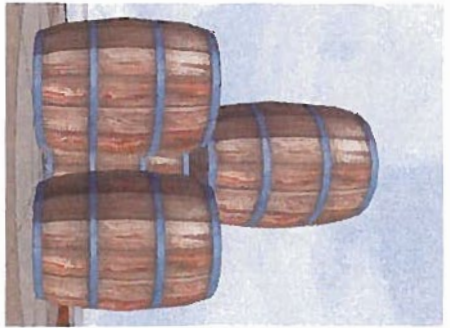

PLANET EARTH'S AIR, WATER, AND SOIL RESOURCES OFFER TO SUPPORT THE WINE INDUSTRY. WINE IS A COMPLEX PRODUCT THAT REQUIRES A CAREFUL APPROACH TO PRODUCTION AND PRESERVATION. THE WINE INDUSTRY IS A GLOBAL INDUSTRY THAT IS GROWING RAPIDLY.

MONUMENT SIGNAGE



DATE: 03/11/14
 PROJECT: NAPA COMMERCE CENTER
 SHEET: A01.4

NO.	REVISION	DATE
1	ISSUED FOR PERMIT	03/11/14
2	REVISED PER COMMENTS	03/11/14
3	REVISED PER COMMENTS	03/11/14
4	REVISED PER COMMENTS	03/11/14
5	REVISED PER COMMENTS	03/11/14
6	REVISED PER COMMENTS	03/11/14
7	REVISED PER COMMENTS	03/11/14
8	REVISED PER COMMENTS	03/11/14
9	REVISED PER COMMENTS	03/11/14
10	REVISED PER COMMENTS	03/11/14

NAPA COMMERCE CENTER
 1000 NAPA STREET, NAPA, CA 94559
 (707) 253-1234
 WWW.NAPACOMMERCECENTER.COM

Napa 04 Holdings LLC
 GREG KALMAN
 ARCHITECT
 1000 NAPA STREET, NAPA, CA 94559
 (707) 253-1234
 WWW.GREGKALMAN.COM

A01.4

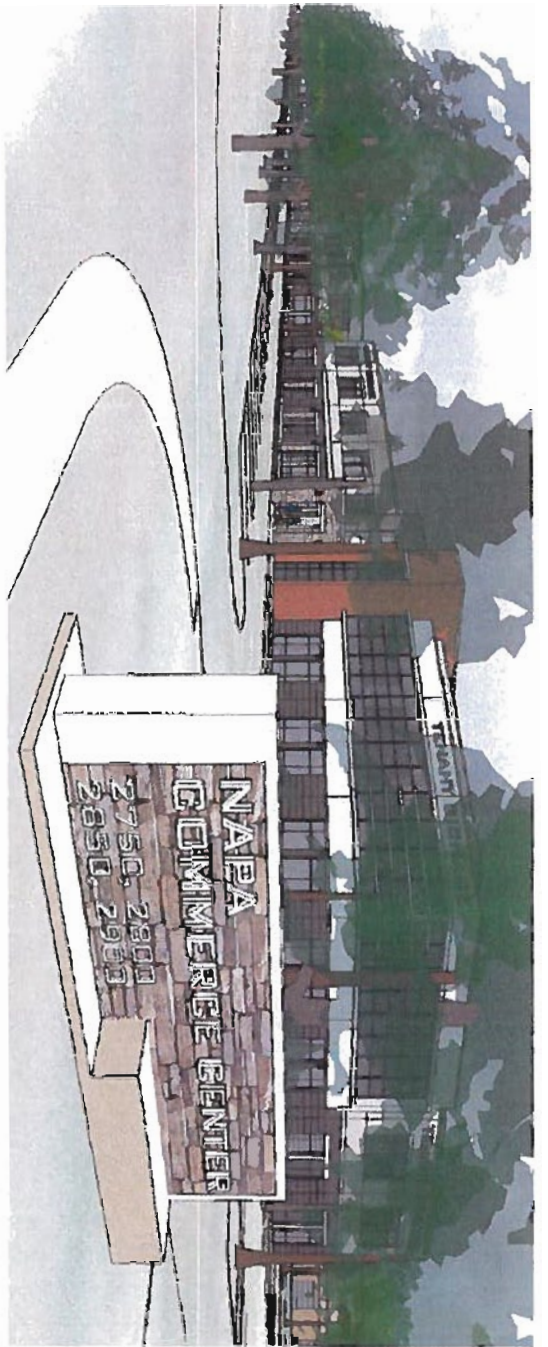

A1. Perspective Rendering

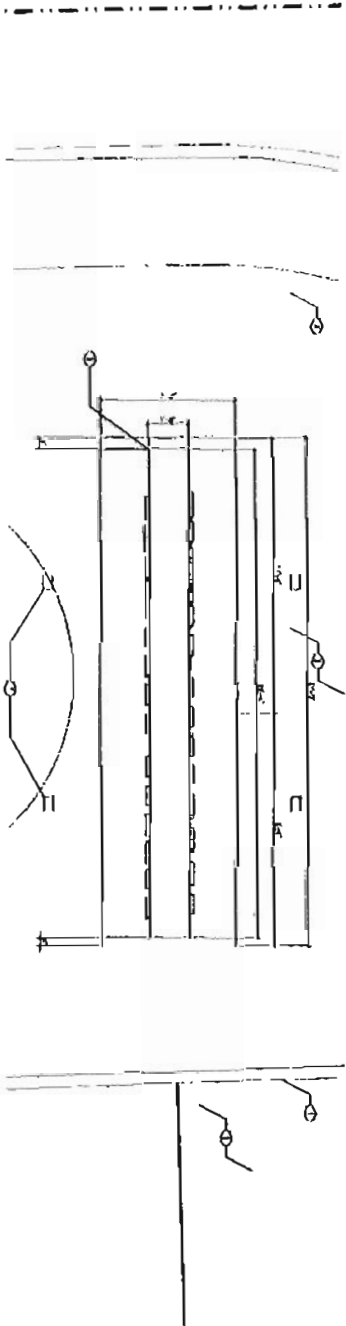

B1. Elevation



B. Elevation View



TYPICAL SIGN GRAPHIC



- NOTES:**
1. SEE SIGNAGE SPECIFICATIONS FOR ALL SIGNAGE.
 2. SEE SIGNAGE SPECIFICATIONS FOR ALL SIGNAGE.
 3. SEE SIGNAGE SPECIFICATIONS FOR ALL SIGNAGE.
 4. SEE SIGNAGE SPECIFICATIONS FOR ALL SIGNAGE.
 5. SEE SIGNAGE SPECIFICATIONS FOR ALL SIGNAGE.
 6. SEE SIGNAGE SPECIFICATIONS FOR ALL SIGNAGE.
 7. SEE SIGNAGE SPECIFICATIONS FOR ALL SIGNAGE.
 8. SEE SIGNAGE SPECIFICATIONS FOR ALL SIGNAGE.
 9. SEE SIGNAGE SPECIFICATIONS FOR ALL SIGNAGE.
 10. SEE SIGNAGE SPECIFICATIONS FOR ALL SIGNAGE.

PLEASE NOTE: ALL SIGNAGE MUST BE APPROVED BY THE LOCAL JURISDICTION TO BE SUBMITTED AS PART OF A COMMERCIAL DEVELOPMENT APPLICATION. THE LOCAL JURISDICTION IS THE LOCAL GOVERNMENT AGENCY THAT HAS JURISDICTION OVER THE SIGNAGE.

MONUMENT SIGNAGE

DATE: 01/15/2015

PROJECT: NAPA COMMERCE CENTER



NO.	DESCRIPTION	QTY	UNIT	PRICE	TOTAL
1	MONUMENT SIGNAGE	1	EA	10000.00	10000.00
2
3
4
5
6
7
8
9
10
11
12
13
14
15
16
17
18
19
20
21
22
23
24
25
26
27
28
29
30
31
32
33
34
35
36
37
38
39
40
41
42
43
44
45
46
47
48
49
50

NAPA COMMERCE CENTER

2750, 2800, 2850, 2900

Napa 34 Holdings LLC

BRIAN KULMAN

ARCHITECT

DATE: 01/15/2015

PROJECT: NAPA COMMERCE CENTER

A01.5

PROVIDE

1. 1/2" DIA. ANCHORS
2. 1/2" DIA. ANCHORS
3. 1/2" DIA. ANCHORS
4. 1/2" DIA. ANCHORS

NAPA 34 Holdings LLC

BRUNN KALPHAY
ARCHITECTS
1000 10th Street
San Francisco, CA 94103
415.774.1100
www.brunnkalphay.com

NAPA COMMERCE CENTER

REVISIONS

NO.	DATE	DESCRIPTION
1	01/15/16	ISSUE FOR PERMITS
2	02/01/16	REVISIONS TO PERMITS
3	02/15/16	REVISIONS TO PERMITS
4	02/25/16	REVISIONS TO PERMITS
5	03/01/16	REVISIONS TO PERMITS
6	03/15/16	REVISIONS TO PERMITS
7	03/25/16	REVISIONS TO PERMITS
8	04/01/16	REVISIONS TO PERMITS
9	04/15/16	REVISIONS TO PERMITS
10	04/25/16	REVISIONS TO PERMITS
11	05/01/16	REVISIONS TO PERMITS
12	05/15/16	REVISIONS TO PERMITS
13	05/25/16	REVISIONS TO PERMITS
14	06/01/16	REVISIONS TO PERMITS
15	06/15/16	REVISIONS TO PERMITS
16	06/25/16	REVISIONS TO PERMITS

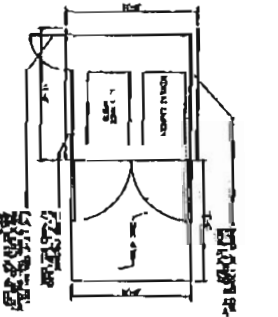

1 WINDOW SILL AND DOOR THRESHOLD

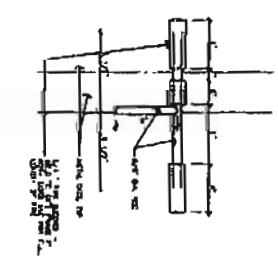

2 WINDOW SILL AND DOOR THRESHOLD

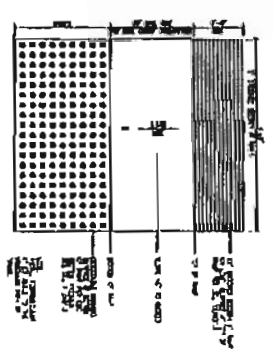

3 WINDOW SILL AND DOOR THRESHOLD

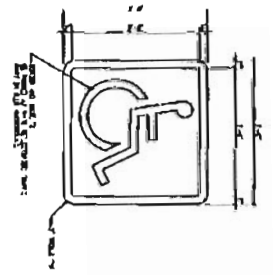

4 WINDOW SILL AND DOOR THRESHOLD

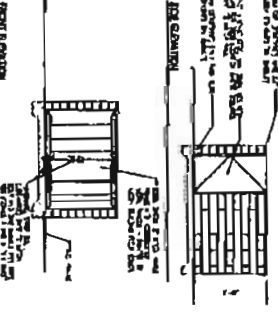

5 WINDOW SILL AND DOOR THRESHOLD

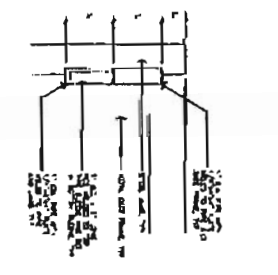

6 WINDOW SILL AND DOOR THRESHOLD

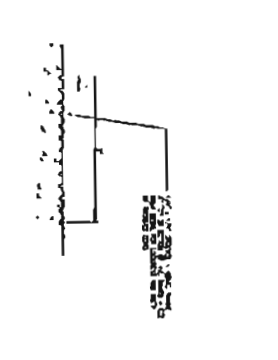

7 WINDOW SILL AND DOOR THRESHOLD

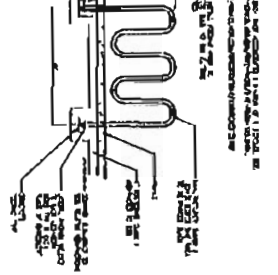

8 WINDOW SILL AND DOOR THRESHOLD

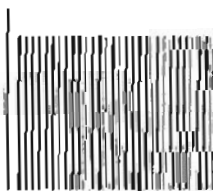

9 WINDOW SILL AND DOOR THRESHOLD

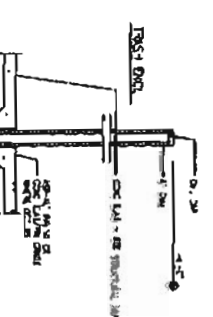

10 WINDOW SILL AND DOOR THRESHOLD

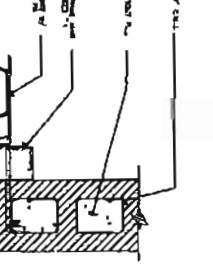

11 WINDOW SILL AND DOOR THRESHOLD

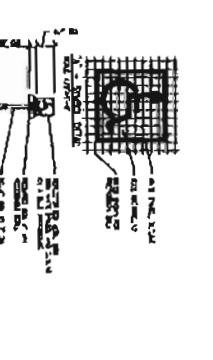

12 WINDOW SILL AND DOOR THRESHOLD



13 WINDOW SILL AND DOOR THRESHOLD



14 WINDOW SILL AND DOOR THRESHOLD

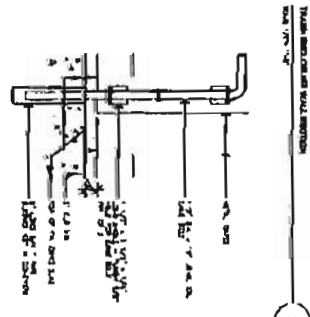

15 WINDOW SILL AND DOOR THRESHOLD

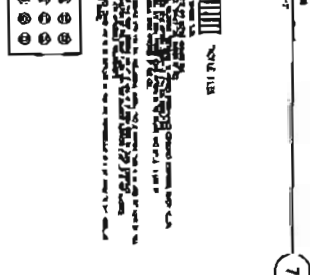

16 WINDOW SILL AND DOOR THRESHOLD

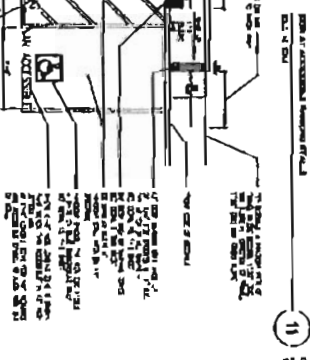

17 WINDOW SILL AND DOOR THRESHOLD

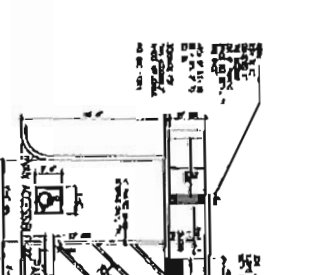

18 WINDOW SILL AND DOOR THRESHOLD

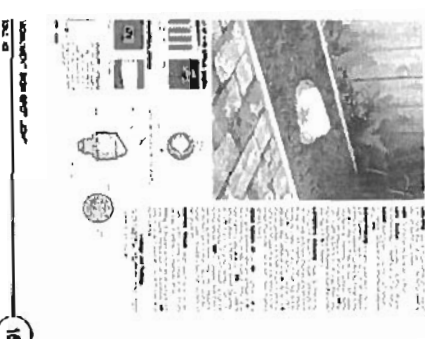

19 PHOTOGRAPH OF EXISTING WALL

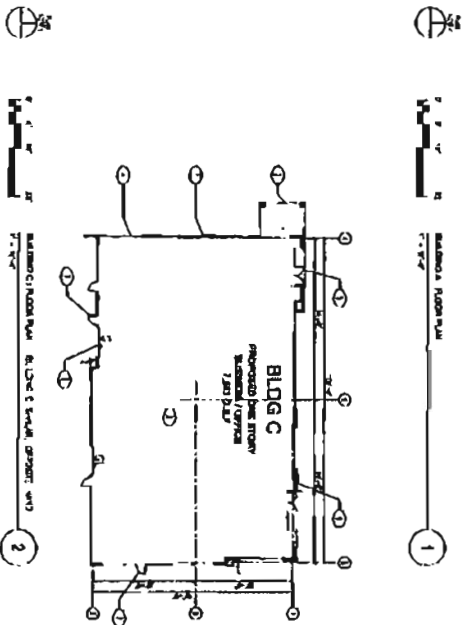
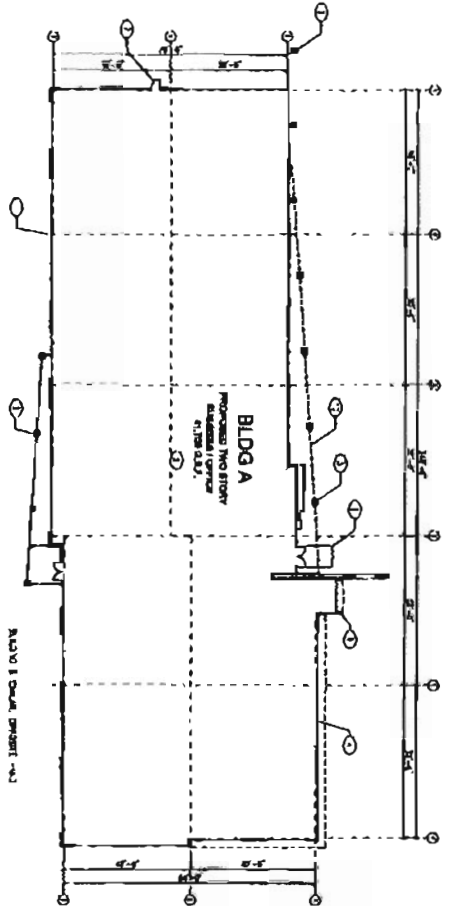
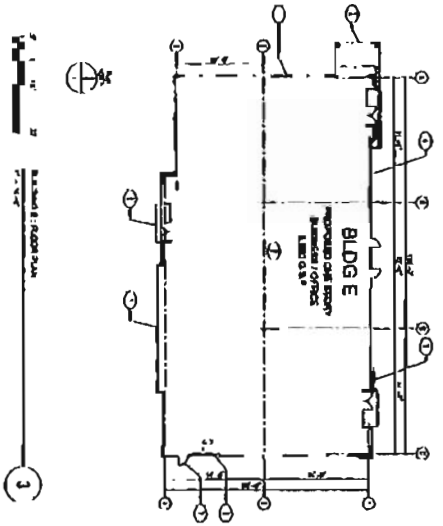

- TYPICAL KEYNOTES:**
- 1. ALL DIMENSIONS UNLESS OTHERWISE NOTED ARE IN FEET AND INCHES.
 - 2. ALL DIMENSIONS UNLESS OTHERWISE NOTED ARE IN FEET AND INCHES.
 - 3. ALL DIMENSIONS UNLESS OTHERWISE NOTED ARE IN FEET AND INCHES.
 - 4. ALL DIMENSIONS UNLESS OTHERWISE NOTED ARE IN FEET AND INCHES.
 - 5. ALL DIMENSIONS UNLESS OTHERWISE NOTED ARE IN FEET AND INCHES.
 - 6. ALL DIMENSIONS UNLESS OTHERWISE NOTED ARE IN FEET AND INCHES.
 - 7. ALL DIMENSIONS UNLESS OTHERWISE NOTED ARE IN FEET AND INCHES.
 - 8. ALL DIMENSIONS UNLESS OTHERWISE NOTED ARE IN FEET AND INCHES.
 - 9. ALL DIMENSIONS UNLESS OTHERWISE NOTED ARE IN FEET AND INCHES.
 - 10. ALL DIMENSIONS UNLESS OTHERWISE NOTED ARE IN FEET AND INCHES.
 - 11. ALL DIMENSIONS UNLESS OTHERWISE NOTED ARE IN FEET AND INCHES.
 - 12. ALL DIMENSIONS UNLESS OTHERWISE NOTED ARE IN FEET AND INCHES.
 - 13. ALL DIMENSIONS UNLESS OTHERWISE NOTED ARE IN FEET AND INCHES.
 - 14. ALL DIMENSIONS UNLESS OTHERWISE NOTED ARE IN FEET AND INCHES.
 - 15. ALL DIMENSIONS UNLESS OTHERWISE NOTED ARE IN FEET AND INCHES.
 - 16. ALL DIMENSIONS UNLESS OTHERWISE NOTED ARE IN FEET AND INCHES.
 - 17. ALL DIMENSIONS UNLESS OTHERWISE NOTED ARE IN FEET AND INCHES.
 - 18. ALL DIMENSIONS UNLESS OTHERWISE NOTED ARE IN FEET AND INCHES.
 - 19. ALL DIMENSIONS UNLESS OTHERWISE NOTED ARE IN FEET AND INCHES.
 - 20. ALL DIMENSIONS UNLESS OTHERWISE NOTED ARE IN FEET AND INCHES.

FLOOR PLAN:
BUILDINGS A - E

A02.1

NAPA COMMERCE CENTER
NAPA HOLDINGS LLC
BRAN KAPLAN
ARCHITECTS
1000 UNIVERSITY AVENUE, SUITE 100
NAPA, CALIFORNIA 94558
TEL: (707) 251-1111
WWW.NAPAARCHITECTS.COM

NO.	DESCRIPTION	DATE
1	PRELIMINARY	08/14/18
2	REVISED	08/14/18
3	REVISED	08/14/18
4	REVISED	08/14/18
5	REVISED	08/14/18
6	REVISED	08/14/18
7	REVISED	08/14/18
8	REVISED	08/14/18
9	REVISED	08/14/18
10	REVISED	08/14/18
11	REVISED	08/14/18
12	REVISED	08/14/18
13	REVISED	08/14/18
14	REVISED	08/14/18
15	REVISED	08/14/18
16	REVISED	08/14/18
17	REVISED	08/14/18
18	REVISED	08/14/18
19	REVISED	08/14/18
20	REVISED	08/14/18

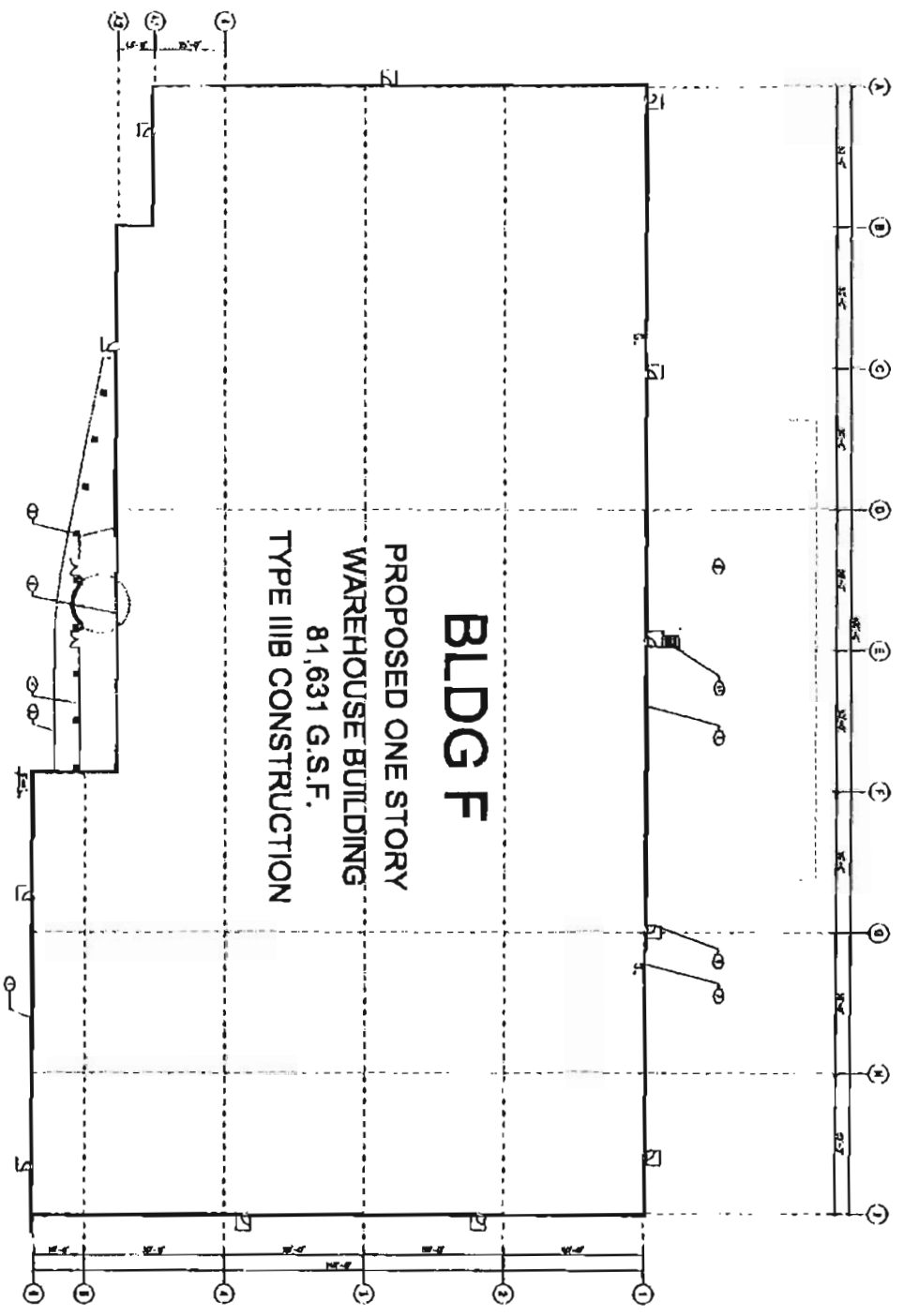

BLDG F
 PROPOSED ONE STORY
 WAREHOUSE BUILDING
 81,631 G.S.F.
 TYPE IIIB CONSTRUCTION

- TYPICAL KEYNOTES:**
- 1) TYPICAL CONCRETE SLAB IS 11" THICK CONCRETE WITH 4" J.C.P. FILL. ALL OTHERS APPROX. PER A.14.10.10.1
 - 2) USE OF 40# REBAR, WITH 10# REBAR
 - 3) 1" OF 2" DIA. COL. AND 2" DIA. BEAM
 - 4) 1" OF 2" DIA. COL. AND 2" DIA. BEAM
 - 5) 1" OF 2" DIA. COL. AND 2" DIA. BEAM
 - 6) 1" OF 2" DIA. COL. AND 2" DIA. BEAM
 - 7) 1" OF 2" DIA. COL. AND 2" DIA. BEAM
 - 8) 1" OF 2" DIA. COL. AND 2" DIA. BEAM
 - 9) 1" OF 2" DIA. COL. AND 2" DIA. BEAM
 - 10) 1" OF 2" DIA. COL. AND 2" DIA. BEAM
 - 11) 1" OF 2" DIA. COL. AND 2" DIA. BEAM



BLDG F FLOOR PLAN



Napa 34 Holdings LLC
 BRIAN WALTMAN
 ARCHITECT OF RECORD

NAPA COMMERCE CENTER

NO.	DESCRIPTION	DATE
1	PRELIMINARY	10/1/11
2	REVISED	10/1/11
3	REVISED	10/1/11
4	REVISED	10/1/11
5	REVISED	10/1/11
6	REVISED	10/1/11
7	REVISED	10/1/11
8	REVISED	10/1/11
9	REVISED	10/1/11
10	REVISED	10/1/11
11	REVISED	10/1/11
12	REVISED	10/1/11
13	REVISED	10/1/11
14	REVISED	10/1/11
15	REVISED	10/1/11
16	REVISED	10/1/11
17	REVISED	10/1/11
18	REVISED	10/1/11
19	REVISED	10/1/11
20	REVISED	10/1/11
21	REVISED	10/1/11
22	REVISED	10/1/11
23	REVISED	10/1/11
24	REVISED	10/1/11
25	REVISED	10/1/11
26	REVISED	10/1/11
27	REVISED	10/1/11
28	REVISED	10/1/11
29	REVISED	10/1/11
30	REVISED	10/1/11
31	REVISED	10/1/11
32	REVISED	10/1/11
33	REVISED	10/1/11
34	REVISED	10/1/11
35	REVISED	10/1/11
36	REVISED	10/1/11
37	REVISED	10/1/11
38	REVISED	10/1/11
39	REVISED	10/1/11
40	REVISED	10/1/11
41	REVISED	10/1/11
42	REVISED	10/1/11
43	REVISED	10/1/11
44	REVISED	10/1/11
45	REVISED	10/1/11
46	REVISED	10/1/11
47	REVISED	10/1/11
48	REVISED	10/1/11
49	REVISED	10/1/11
50	REVISED	10/1/11

FLOOR PLAN:
 BUILDING F

1/2" = 1'-0" Scale
 ALL DIMENSIONS IN FEET AND INCHES
 UNLESS OTHERWISE NOTED

Napa 34 Holdings LLC
BROOK WALPMAN
 ARCHITECT
 1000 CALIFORNIA STREET
 SAN FRANCISCO, CA 94108

NAPA COMMERCE CENTER

1000 CALIFORNIA STREET
 SAN FRANCISCO, CA 94108

NO.	DESCRIPTION	DATE
1	ISSUED FOR PERMITS	08/15/2017
2	REVISIONS	
3	REVISIONS	
4	REVISIONS	
5	REVISIONS	
6	REVISIONS	
7	REVISIONS	
8	REVISIONS	
9	REVISIONS	
10	REVISIONS	
11	REVISIONS	
12	REVISIONS	
13	REVISIONS	
14	REVISIONS	
15	REVISIONS	
16	REVISIONS	
17	REVISIONS	
18	REVISIONS	
19	REVISIONS	
20	REVISIONS	
21	REVISIONS	
22	REVISIONS	
23	REVISIONS	
24	REVISIONS	
25	REVISIONS	
26	REVISIONS	
27	REVISIONS	
28	REVISIONS	
29	REVISIONS	
30	REVISIONS	
31	REVISIONS	
32	REVISIONS	
33	REVISIONS	
34	REVISIONS	
35	REVISIONS	
36	REVISIONS	
37	REVISIONS	
38	REVISIONS	
39	REVISIONS	
40	REVISIONS	
41	REVISIONS	
42	REVISIONS	
43	REVISIONS	
44	REVISIONS	
45	REVISIONS	
46	REVISIONS	
47	REVISIONS	
48	REVISIONS	
49	REVISIONS	
50	REVISIONS	

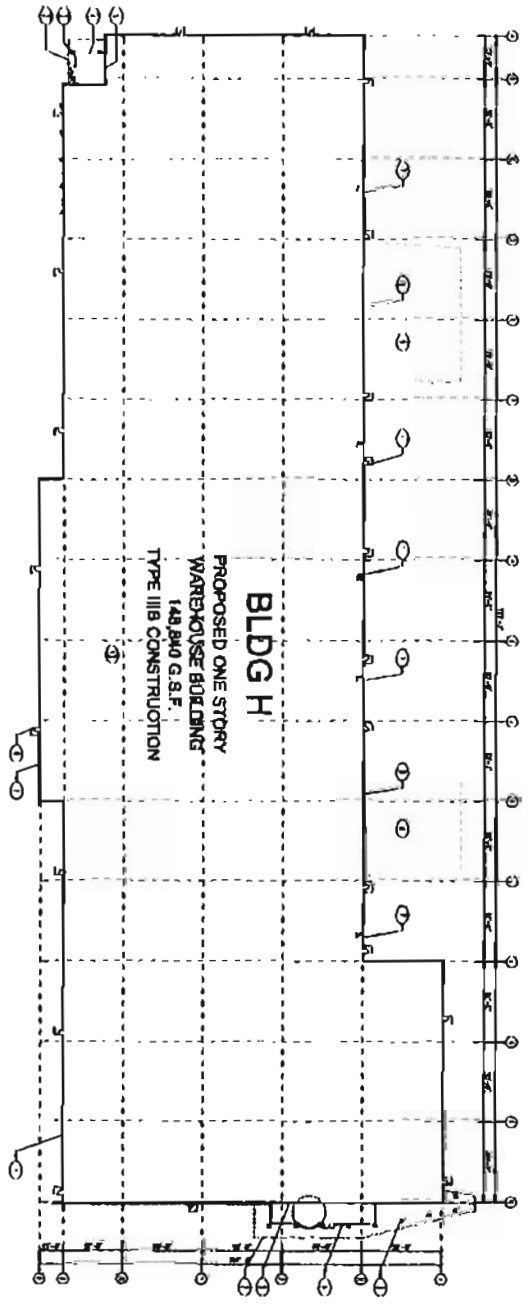

- TYPICAL NOTES:**
- 1. ALL DIMENSIONS ARE TO FACE UNLESS OTHERWISE NOTED.
 - 2. ALL WALLS ARE TO BE CONCRETE UNLESS OTHERWISE NOTED.
 - 3. ALL FLOORS ARE TO BE CONCRETE UNLESS OTHERWISE NOTED.
 - 4. ALL CEILING ARE TO BE CONCRETE UNLESS OTHERWISE NOTED.
 - 5. ALL ROOF ARE TO BE CONCRETE UNLESS OTHERWISE NOTED.
 - 6. ALL EXTERIOR WALLS ARE TO BE CONCRETE UNLESS OTHERWISE NOTED.
 - 7. ALL EXTERIOR ROOF ARE TO BE CONCRETE UNLESS OTHERWISE NOTED.
 - 8. ALL EXTERIOR FLOORS ARE TO BE CONCRETE UNLESS OTHERWISE NOTED.
 - 9. ALL EXTERIOR CEILING ARE TO BE CONCRETE UNLESS OTHERWISE NOTED.
 - 10. ALL EXTERIOR ROOF ARE TO BE CONCRETE UNLESS OTHERWISE NOTED.
 - 11. ALL EXTERIOR WALLS ARE TO BE CONCRETE UNLESS OTHERWISE NOTED.
 - 12. ALL EXTERIOR ROOF ARE TO BE CONCRETE UNLESS OTHERWISE NOTED.
 - 13. ALL EXTERIOR FLOORS ARE TO BE CONCRETE UNLESS OTHERWISE NOTED.
 - 14. ALL EXTERIOR CEILING ARE TO BE CONCRETE UNLESS OTHERWISE NOTED.
 - 15. ALL EXTERIOR ROOF ARE TO BE CONCRETE UNLESS OTHERWISE NOTED.
 - 16. ALL EXTERIOR WALLS ARE TO BE CONCRETE UNLESS OTHERWISE NOTED.
 - 17. ALL EXTERIOR ROOF ARE TO BE CONCRETE UNLESS OTHERWISE NOTED.
 - 18. ALL EXTERIOR FLOORS ARE TO BE CONCRETE UNLESS OTHERWISE NOTED.
 - 19. ALL EXTERIOR CEILING ARE TO BE CONCRETE UNLESS OTHERWISE NOTED.
 - 20. ALL EXTERIOR ROOF ARE TO BE CONCRETE UNLESS OTHERWISE NOTED.
 - 21. ALL EXTERIOR WALLS ARE TO BE CONCRETE UNLESS OTHERWISE NOTED.
 - 22. ALL EXTERIOR ROOF ARE TO BE CONCRETE UNLESS OTHERWISE NOTED.
 - 23. ALL EXTERIOR FLOORS ARE TO BE CONCRETE UNLESS OTHERWISE NOTED.
 - 24. ALL EXTERIOR CEILING ARE TO BE CONCRETE UNLESS OTHERWISE NOTED.
 - 25. ALL EXTERIOR ROOF ARE TO BE CONCRETE UNLESS OTHERWISE NOTED.
 - 26. ALL EXTERIOR WALLS ARE TO BE CONCRETE UNLESS OTHERWISE NOTED.
 - 27. ALL EXTERIOR ROOF ARE TO BE CONCRETE UNLESS OTHERWISE NOTED.
 - 28. ALL EXTERIOR FLOORS ARE TO BE CONCRETE UNLESS OTHERWISE NOTED.
 - 29. ALL EXTERIOR CEILING ARE TO BE CONCRETE UNLESS OTHERWISE NOTED.
 - 30. ALL EXTERIOR ROOF ARE TO BE CONCRETE UNLESS OTHERWISE NOTED.
 - 31. ALL EXTERIOR WALLS ARE TO BE CONCRETE UNLESS OTHERWISE NOTED.
 - 32. ALL EXTERIOR ROOF ARE TO BE CONCRETE UNLESS OTHERWISE NOTED.
 - 33. ALL EXTERIOR FLOORS ARE TO BE CONCRETE UNLESS OTHERWISE NOTED.
 - 34. ALL EXTERIOR CEILING ARE TO BE CONCRETE UNLESS OTHERWISE NOTED.
 - 35. ALL EXTERIOR ROOF ARE TO BE CONCRETE UNLESS OTHERWISE NOTED.
 - 36. ALL EXTERIOR WALLS ARE TO BE CONCRETE UNLESS OTHERWISE NOTED.
 - 37. ALL EXTERIOR ROOF ARE TO BE CONCRETE UNLESS OTHERWISE NOTED.
 - 38. ALL EXTERIOR FLOORS ARE TO BE CONCRETE UNLESS OTHERWISE NOTED.
 - 39. ALL EXTERIOR CEILING ARE TO BE CONCRETE UNLESS OTHERWISE NOTED.
 - 40. ALL EXTERIOR ROOF ARE TO BE CONCRETE UNLESS OTHERWISE NOTED.
 - 41. ALL EXTERIOR WALLS ARE TO BE CONCRETE UNLESS OTHERWISE NOTED.
 - 42. ALL EXTERIOR ROOF ARE TO BE CONCRETE UNLESS OTHERWISE NOTED.
 - 43. ALL EXTERIOR FLOORS ARE TO BE CONCRETE UNLESS OTHERWISE NOTED.
 - 44. ALL EXTERIOR CEILING ARE TO BE CONCRETE UNLESS OTHERWISE NOTED.
 - 45. ALL EXTERIOR ROOF ARE TO BE CONCRETE UNLESS OTHERWISE NOTED.
 - 46. ALL EXTERIOR WALLS ARE TO BE CONCRETE UNLESS OTHERWISE NOTED.
 - 47. ALL EXTERIOR ROOF ARE TO BE CONCRETE UNLESS OTHERWISE NOTED.
 - 48. ALL EXTERIOR FLOORS ARE TO BE CONCRETE UNLESS OTHERWISE NOTED.
 - 49. ALL EXTERIOR CEILING ARE TO BE CONCRETE UNLESS OTHERWISE NOTED.
 - 50. ALL EXTERIOR ROOF ARE TO BE CONCRETE UNLESS OTHERWISE NOTED.

FLOOR PLAN :
BUILDING H

A02.4

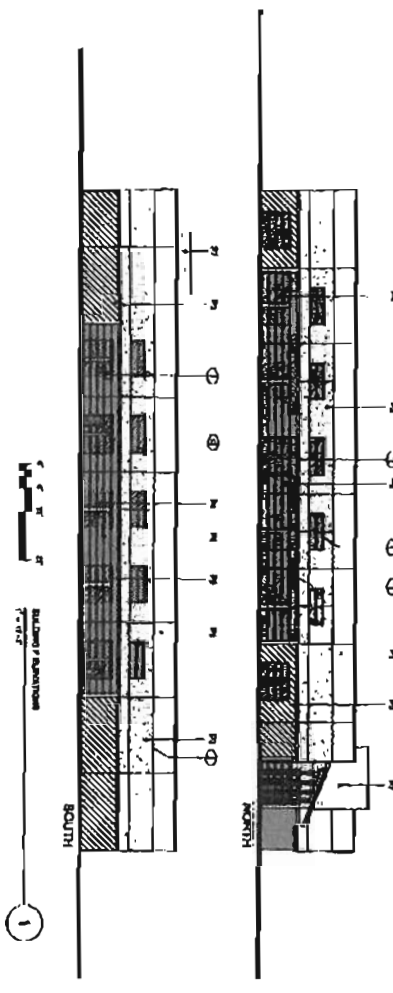
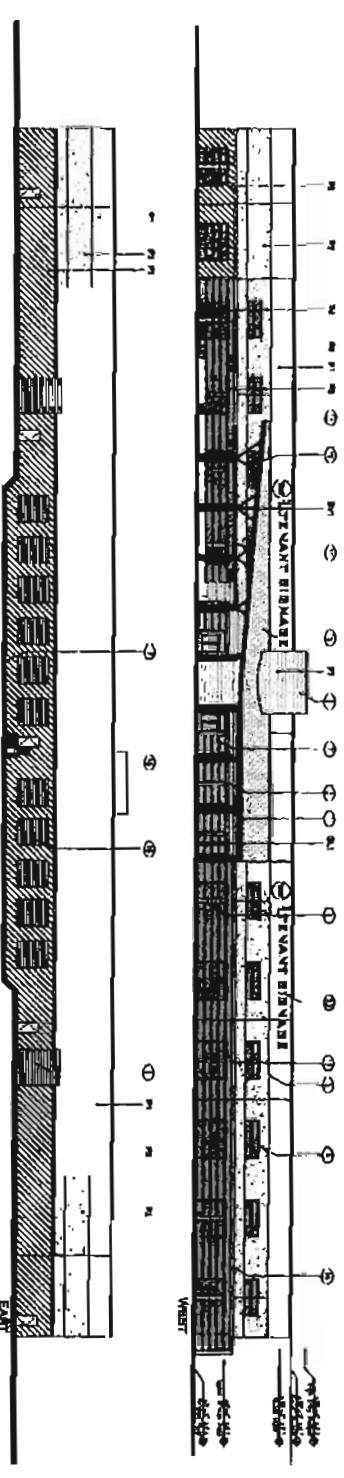

FRESH LEADINGS:

- GL1: EXTENSION GLAZING 1
VIBRATED GREEN TINTED
FLOAT GLASS
- GL2: EXTENSION GLAZING 2
PING HEADCAPES
SOLARCOOL (2) AZURIA
GREEN TINTED FLOAT GLASS
- AL1: ALUMINUM MULLIONS
ARCADIA OR SOLAR
2" X 4" NOMINAL MULLIONS
CLEAR ANODIZED ALUMINUM
- MS1: METAL WALL PANELS
AEP SPAN
28 GA. BOX RIB WALL PANELS
ZINCALUME
- ST1: STONE VENEER
BLONDADO STONE
RUSTIC LEADS
PINE TOP
- WD1: EXPOSED GUT LAM BEAMS
SHERWIN WALLMATS
SHERWOOD STAIN / SEALER
CHEVY 584 R 8

- PT1: TRANSLUCENT POLYCARBONATE
PANELS
POLYVAL 18 LAM RFX SELECTOVAL RED
1/2" LAM
- PI: PAINT 1
PAINT 1 LUMBERT
33-30
GRAY MOORE
- PT2: PAINT 2
PITTSBURGH PAINT
PPG 3144
SPICED VINEGAR
- PT3: PAINT 3
PAINT 3 LUMBERT
11-24
MAYA
- PT4: PAINT 4
SHERWIN WALLMATS
584 EDY
RETRIEVAL
- PT5: PAINT 5
PITTSBURGH PAINT
PPG 44-2
LITTLE DRIPPER
- PT6: PAINT 6
SHERWIN WALLMATS
89V 8040
LEGS BROWN
- PT7: PAINT 7
PITTSBURGH PAINT
PPG 320-7
GANDER

TYPICAL NOTES:

1. ALL WORK SHALL BE DONE IN ACCORDANCE WITH THE LATEST EDITIONS OF THE BUILDING CODES AND ALL APPLICABLE REGULATIONS.
2. ALL MATERIALS SHALL BE OF THE HIGHEST QUALITY AND SHALL BE SUBJECT TO INSPECTION AND APPROVAL BY THE ARCHITECT.
3. ALL WORK SHALL BE DONE IN ACCORDANCE WITH THE LATEST EDITIONS OF THE BUILDING CODES AND ALL APPLICABLE REGULATIONS.
4. ALL MATERIALS SHALL BE OF THE HIGHEST QUALITY AND SHALL BE SUBJECT TO INSPECTION AND APPROVAL BY THE ARCHITECT.
5. ALL WORK SHALL BE DONE IN ACCORDANCE WITH THE LATEST EDITIONS OF THE BUILDING CODES AND ALL APPLICABLE REGULATIONS.
6. ALL MATERIALS SHALL BE OF THE HIGHEST QUALITY AND SHALL BE SUBJECT TO INSPECTION AND APPROVAL BY THE ARCHITECT.
7. ALL WORK SHALL BE DONE IN ACCORDANCE WITH THE LATEST EDITIONS OF THE BUILDING CODES AND ALL APPLICABLE REGULATIONS.
8. ALL MATERIALS SHALL BE OF THE HIGHEST QUALITY AND SHALL BE SUBJECT TO INSPECTION AND APPROVAL BY THE ARCHITECT.
9. ALL WORK SHALL BE DONE IN ACCORDANCE WITH THE LATEST EDITIONS OF THE BUILDING CODES AND ALL APPLICABLE REGULATIONS.
10. ALL MATERIALS SHALL BE OF THE HIGHEST QUALITY AND SHALL BE SUBJECT TO INSPECTION AND APPROVAL BY THE ARCHITECT.

NAPA COMMERCE CENTER
 BUILDING F:
 EXTERIOR
 ELEVATIONS

Napa 34 Holdings LLC
 BRUNN KALININA
 1801 CALISTO
 SACRAMENTO, CA 95811

ARCHITECT
 NAPA COMMERCE CENTER
 1801 CALISTO
 SACRAMENTO, CA 95811

DATE
 10/15/2024

PROJECT
 NAPA COMMERCE CENTER
 1801 CALISTO
 SACRAMENTO, CA 95811

SCALE
 1/8" = 1'-0"

NO. 103.2

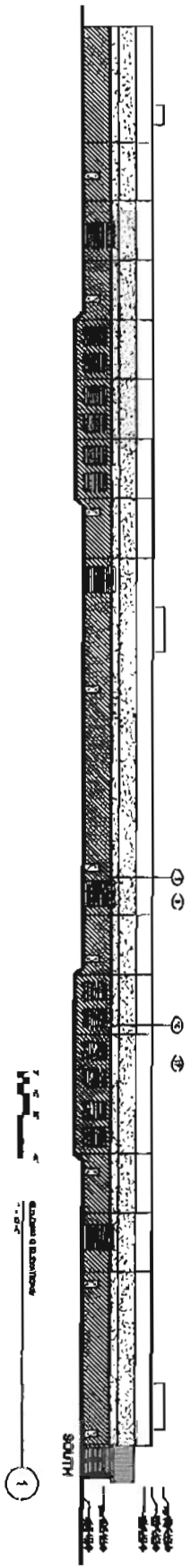
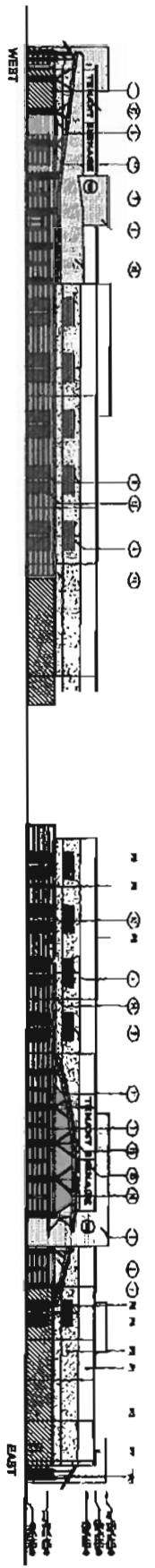
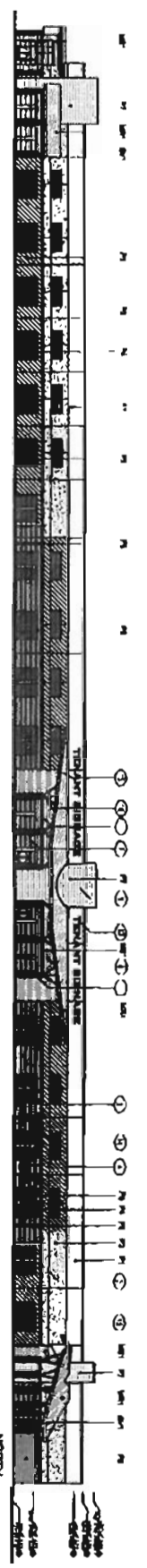

ALL MATERIALS TO BE USED IN THIS PROJECT SHALL BE OF THE HIGHEST QUALITY AND SHALL BE SUBJECT TO THE APPROVAL OF THE ARCHITECT. ALL MATERIALS SHALL BE INSTALLED IN ACCORDANCE WITH THE MANUFACTURER'S INSTRUCTIONS AND THE LATEST EDITIONS OF THE BUILDING CODES.

FINISH LEGEND:

- 1. 3/4" THICK POLISHED CONCRETE
- 2. 1/2" THICK POLISHED CONCRETE
- 3. 1/4" THICK POLISHED CONCRETE
- 4. 1/8" THICK POLISHED CONCRETE
- 5. 1/16" THICK POLISHED CONCRETE
- 6. 1/32" THICK POLISHED CONCRETE
- 7. 1/64" THICK POLISHED CONCRETE
- 8. 1/128" THICK POLISHED CONCRETE
- 9. 1/256" THICK POLISHED CONCRETE
- 10. 1/512" THICK POLISHED CONCRETE
- 11. 1/1024" THICK POLISHED CONCRETE
- 12. 1/2048" THICK POLISHED CONCRETE
- 13. 1/4096" THICK POLISHED CONCRETE
- 14. 1/8192" THICK POLISHED CONCRETE
- 15. 1/16384" THICK POLISHED CONCRETE
- 16. 1/32768" THICK POLISHED CONCRETE
- 17. 1/65536" THICK POLISHED CONCRETE
- 18. 1/131072" THICK POLISHED CONCRETE
- 19. 1/262144" THICK POLISHED CONCRETE
- 20. 1/524288" THICK POLISHED CONCRETE
- 21. 1/1048576" THICK POLISHED CONCRETE
- 22. 1/2097152" THICK POLISHED CONCRETE
- 23. 1/4194304" THICK POLISHED CONCRETE
- 24. 1/8388608" THICK POLISHED CONCRETE
- 25. 1/16777216" THICK POLISHED CONCRETE

REMARKS:

- 1. SEE FINISH LEGEND FOR FINISH SCHEDULE.
- 2. SEE FINISH LEGEND FOR FINISH SCHEDULE.
- 3. SEE FINISH LEGEND FOR FINISH SCHEDULE.
- 4. SEE FINISH LEGEND FOR FINISH SCHEDULE.
- 5. SEE FINISH LEGEND FOR FINISH SCHEDULE.
- 6. SEE FINISH LEGEND FOR FINISH SCHEDULE.
- 7. SEE FINISH LEGEND FOR FINISH SCHEDULE.
- 8. SEE FINISH LEGEND FOR FINISH SCHEDULE.
- 9. SEE FINISH LEGEND FOR FINISH SCHEDULE.
- 10. SEE FINISH LEGEND FOR FINISH SCHEDULE.
- 11. SEE FINISH LEGEND FOR FINISH SCHEDULE.
- 12. SEE FINISH LEGEND FOR FINISH SCHEDULE.
- 13. SEE FINISH LEGEND FOR FINISH SCHEDULE.
- 14. SEE FINISH LEGEND FOR FINISH SCHEDULE.
- 15. SEE FINISH LEGEND FOR FINISH SCHEDULE.
- 16. SEE FINISH LEGEND FOR FINISH SCHEDULE.
- 17. SEE FINISH LEGEND FOR FINISH SCHEDULE.
- 18. SEE FINISH LEGEND FOR FINISH SCHEDULE.
- 19. SEE FINISH LEGEND FOR FINISH SCHEDULE.
- 20. SEE FINISH LEGEND FOR FINISH SCHEDULE.
- 21. SEE FINISH LEGEND FOR FINISH SCHEDULE.
- 22. SEE FINISH LEGEND FOR FINISH SCHEDULE.
- 23. SEE FINISH LEGEND FOR FINISH SCHEDULE.
- 24. SEE FINISH LEGEND FOR FINISH SCHEDULE.
- 25. SEE FINISH LEGEND FOR FINISH SCHEDULE.

NAPA HOLDINGS LLC
 3100 MARKET STREET
 SUITE 200
 NAPA, CALIFORNIA 94558
 TEL: (707) 251-1111
 FAX: (707) 251-1112
 WWW.NAPAHOLDINGS.COM

NAPA COMMERCE CENTER
 BRUNN MAUSMAN
 ARCHITECTS
 1000 CALIFORNIA STREET
 SUITE 200
 NAPA, CALIFORNIA 94558
 TEL: (707) 251-1111
 FAX: (707) 251-1112
 WWW.BRUNNMAUSMAN.COM

NO.	DESCRIPTION	QTY	UNIT	PRICE	TOTAL
1	CONCRETE	1000	CU YD	120.00	120000.00
2	STEEL	500	TON	100.00	50000.00
3	WOOD	200	CU YD	80.00	16000.00
4	GLASS	100	SQ FT	100.00	10000.00
5	PAINT	50	TON	200.00	10000.00
6	MECHANICAL	100	UNIT	100.00	10000.00
7	ELECTRICAL	100	UNIT	100.00	10000.00
8	PLUMBING	100	UNIT	100.00	10000.00
9	FINISHES	100	UNIT	100.00	10000.00
10	LABOR	1000	HR	100.00	100000.00
11	PERMITS	1	SET	10000.00	10000.00
12	INSURANCE	1	YEAR	10000.00	10000.00
13	CONTINGENCY	1	PERCENT	10000.00	10000.00
14	TOTAL				500000.00

**BUILDING G :
 EXTERIOR
 ELEVATIONS**
 PROJECT NO. A03.3

